

Department of Urban Development & Building
Construction (DUDBC)
Regional Urban Development Project (RUDP)
West Urban Corridor (WUC) Development Project
Babarmahal, Kathmandu, Nepal

Reviewed & Designed By :
DOHWA Engineering Co. Ltd.
in Association with
ERMIC (P.) Ltd., SILT Consultants (P.) Ltd., and
DIGICON (P.) Ltd.
Mid- Baneshwor, Kathmandu
Tel: 01- 4589393

Consultant
Team Leader : YOO CHANGMIN
Reviewed By : YAGYA BAHADUR MALLA
Designed By : MANJU MUNANKARMI

Client
Approved By :
Checked By :

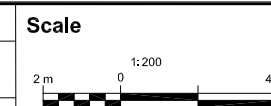

Cross-Section
BANCHAUKI-MAYADEVI PARK- MILDANDA
- BUDDHA CIRCUIT ROAD
CH 0+000 - 4+941.092 Km

REV : MAY 2024
DRG NO : DM/RD/CS/1
CHAINAGE : 0+000-0+140
SHEET NO : 1

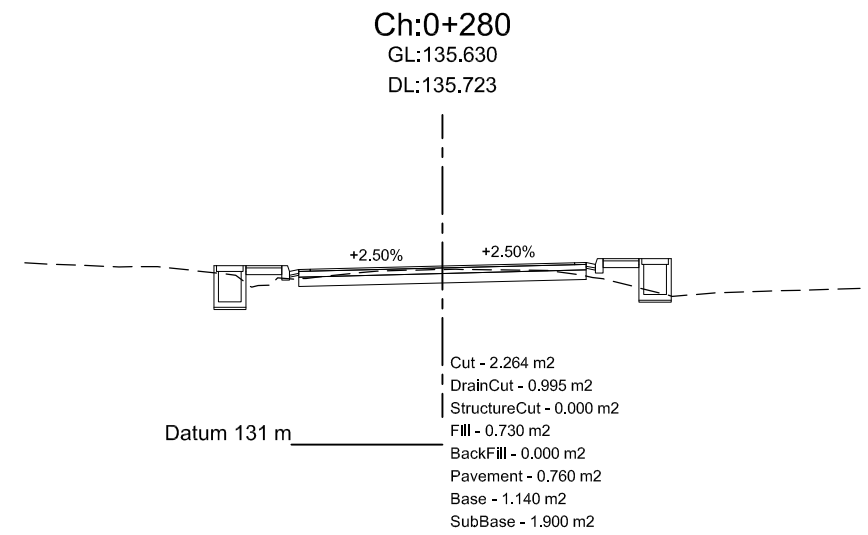
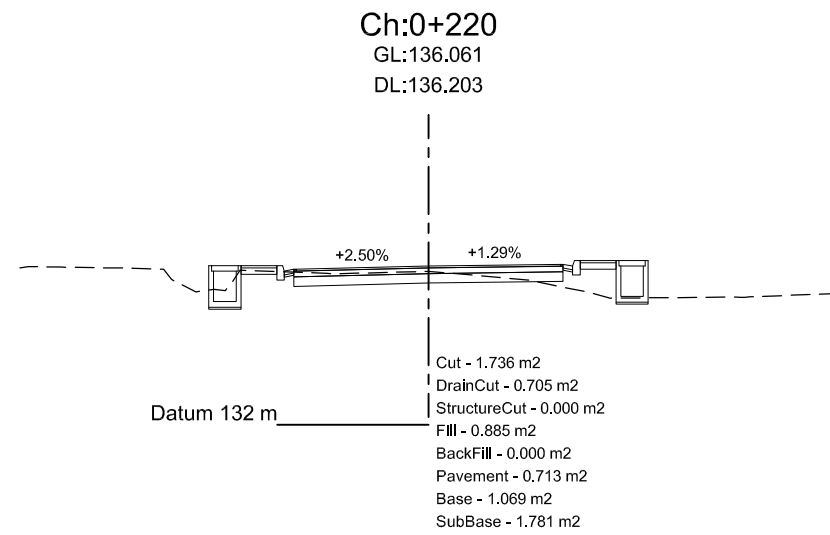
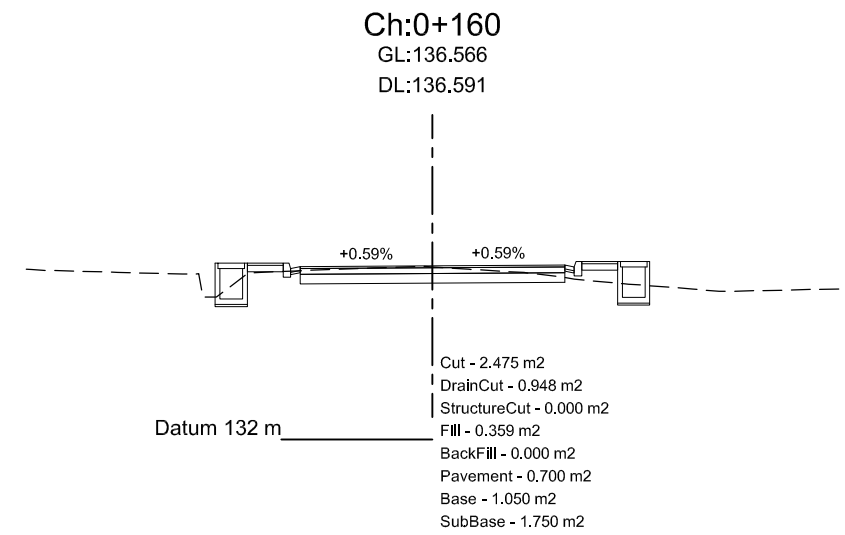
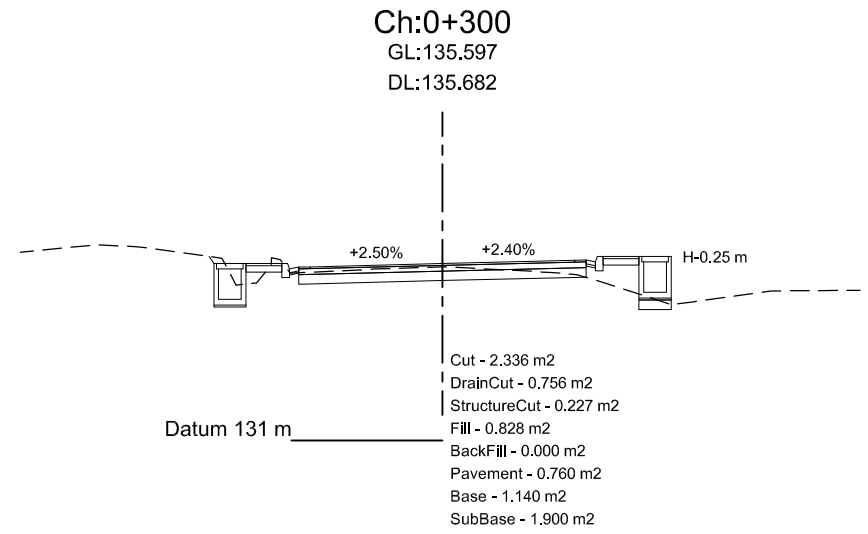
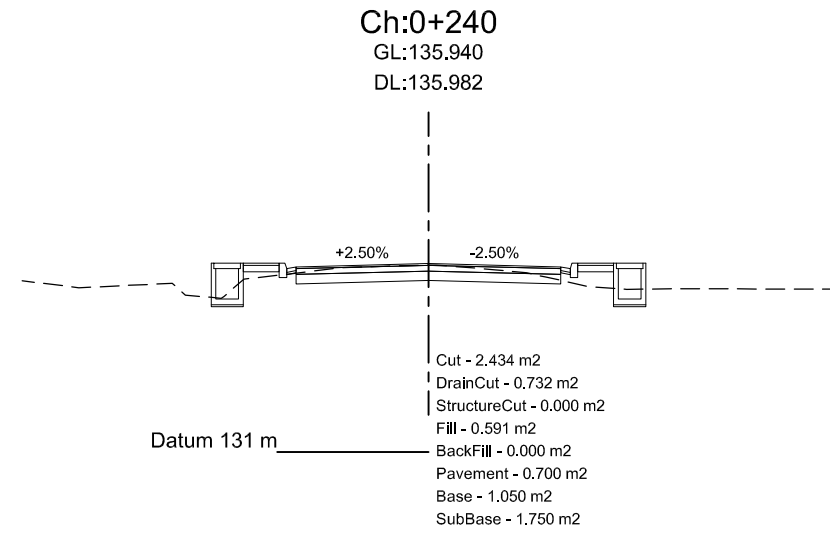
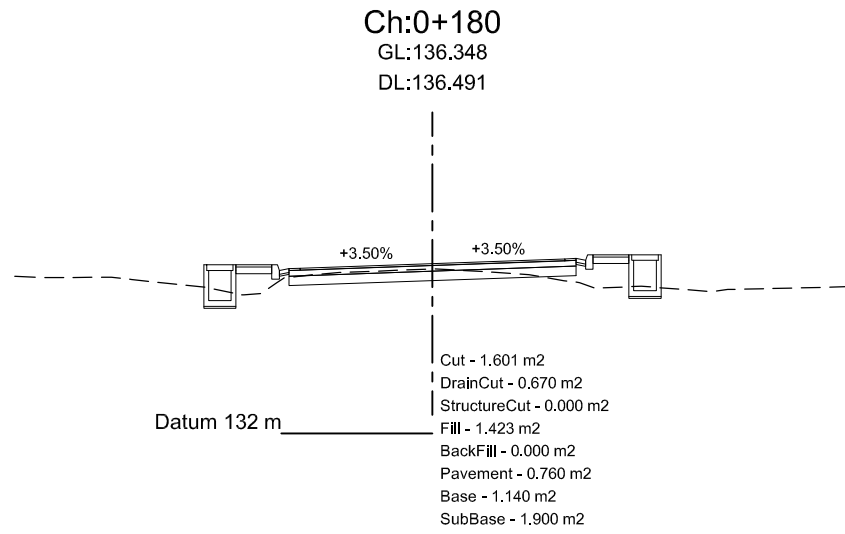
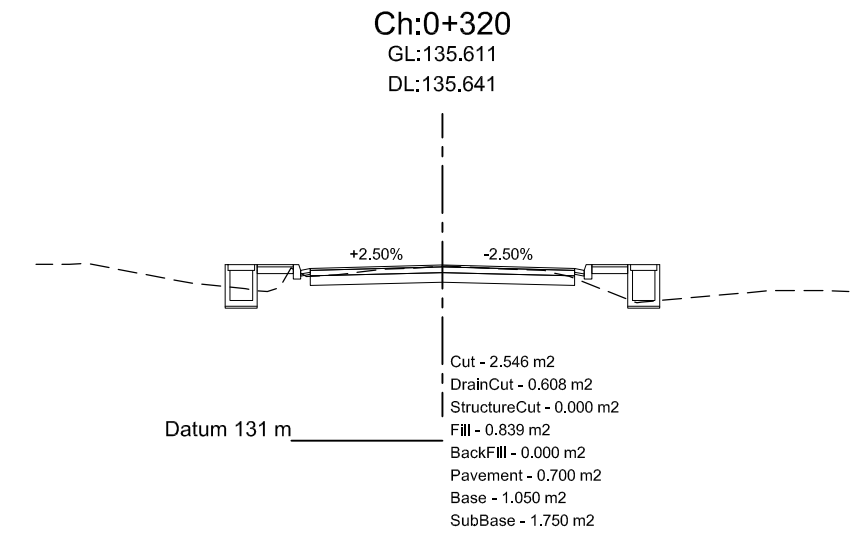
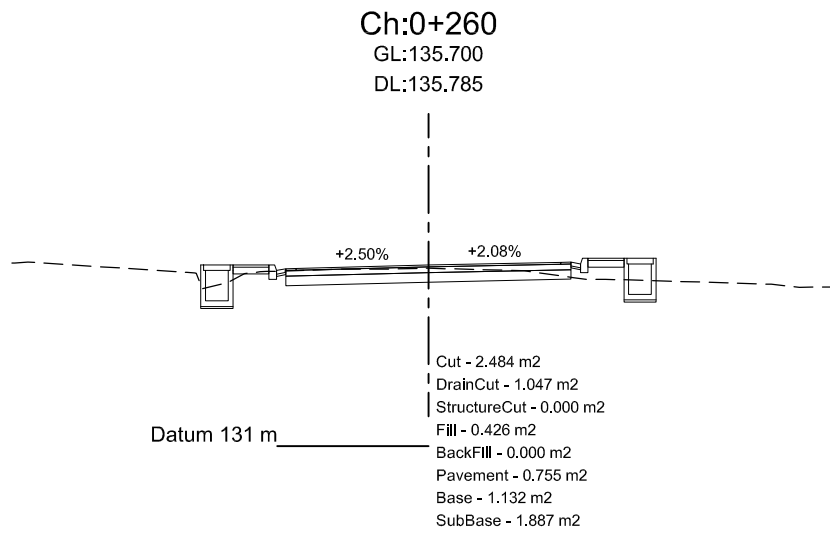
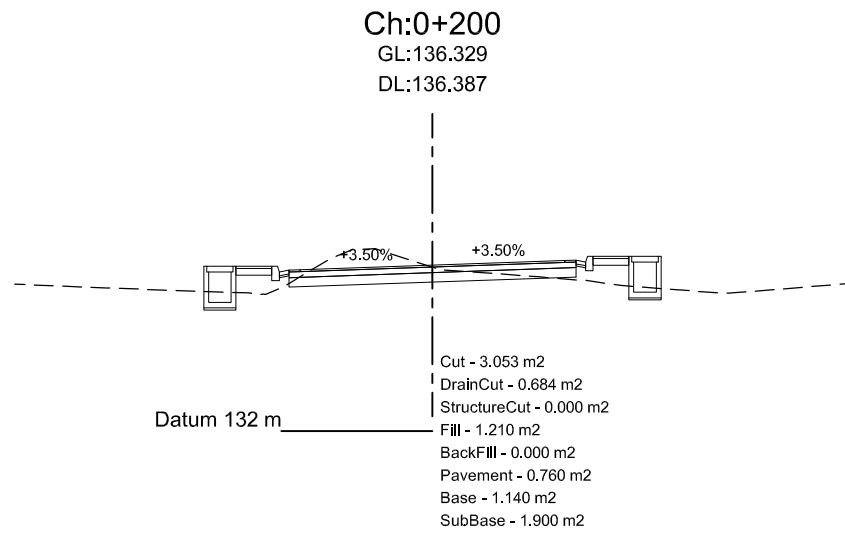

Department of Urban Development & Building
Construction (DUDBC)
Regional Urban Development Project (RUDP)
West Urban Corridor (WUC) Development Project
Babarmahal, Kathmandu, Nepal

Reviewed & Designed By :
DOHWA Engineering Co. Ltd.
in Association with
ERMIC (P.) Ltd., SILT Consultants (P.) Ltd., and
DIGICON (P.) Ltd.
Mid- Baneshwor, Kathmandu
Tel: 01- 4589393

Consultant
Team Leader : YOO CHANGMIN
Reviewed By : YAGYA BAHADUR MALLA
Designed By : MANJU MUNANKARMI

Client
Approved By :
Checked By :

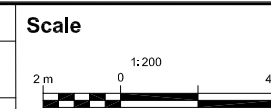

Cross-Section
BANCHAUKI-MAYADEVI PARK- MILDANDA
- BUDDHA CIRCUIT ROAD
CH 0+000 - 4+941.092 Km

REV : MAY 2024
DRG NO : DM/RD/CS/2
CHAINAGE : 0+160-0+320
SHEET NO : 2

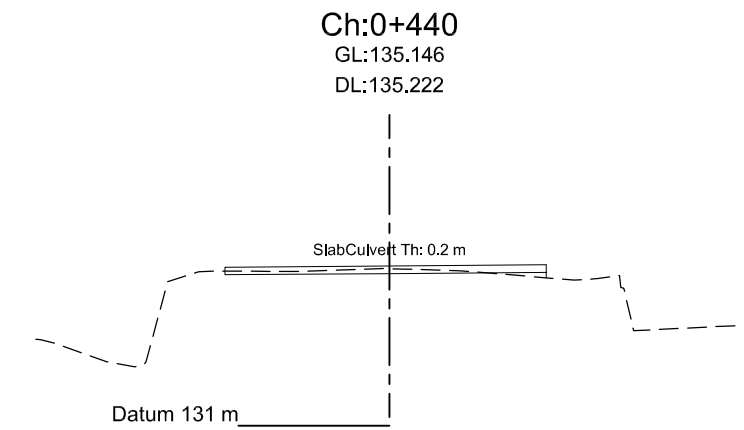
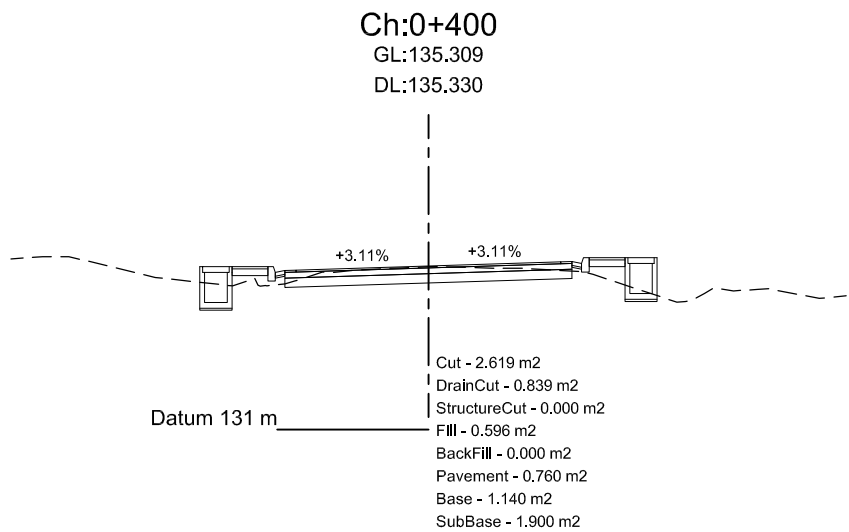
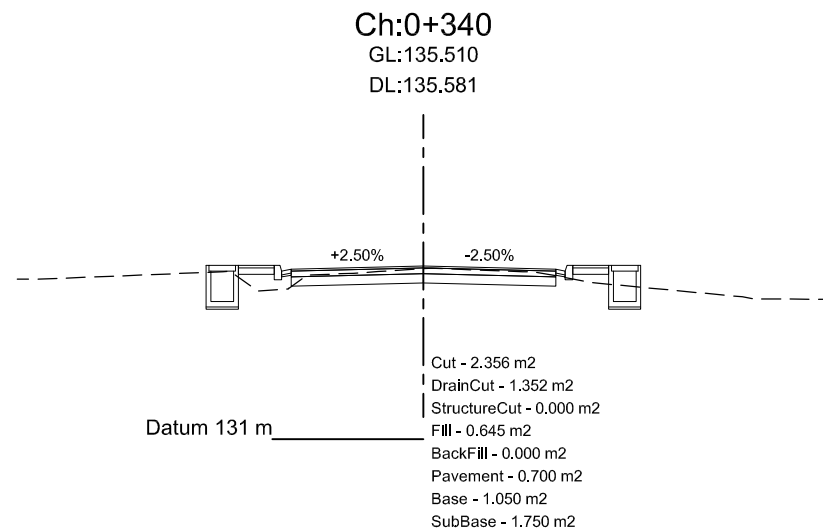
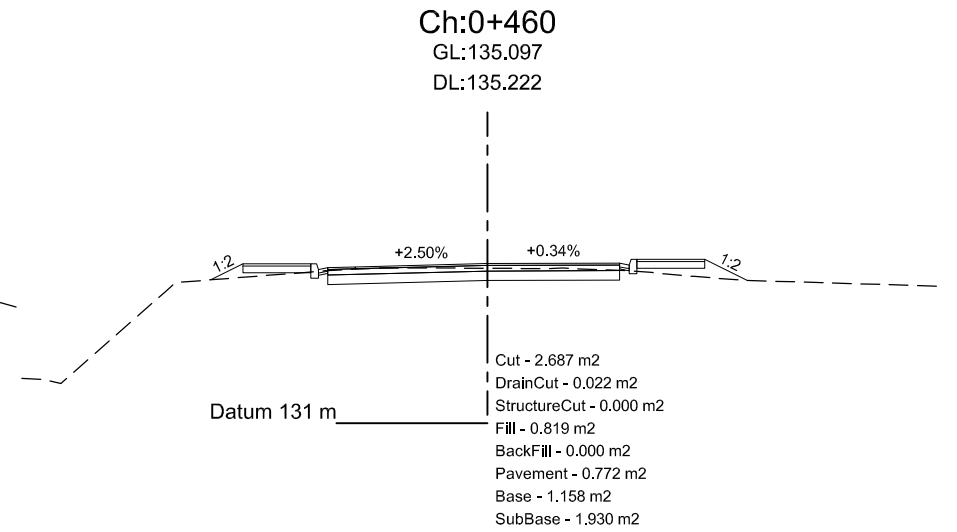
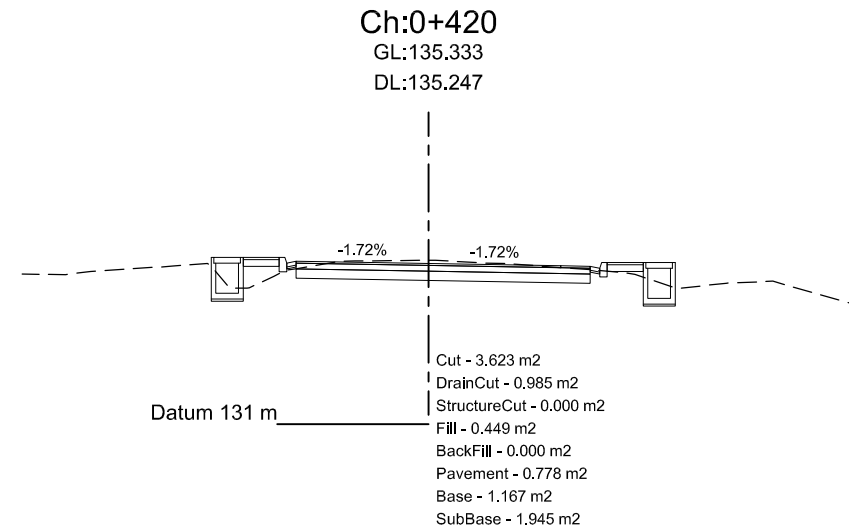
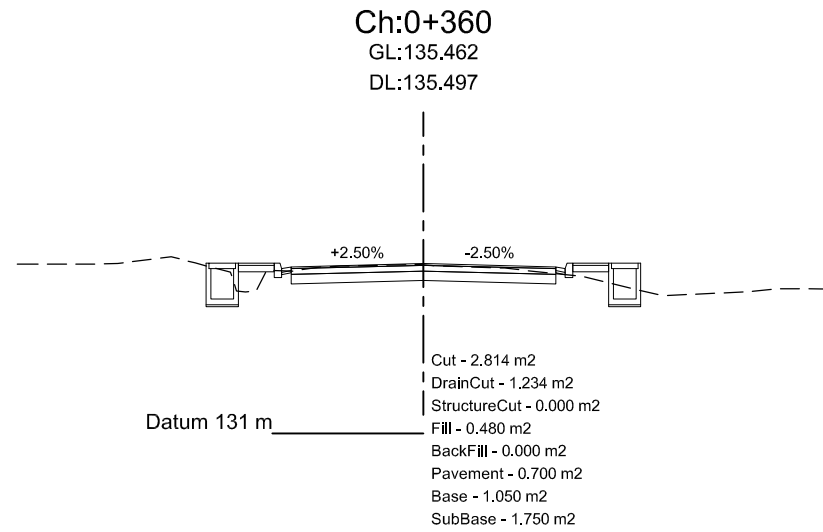
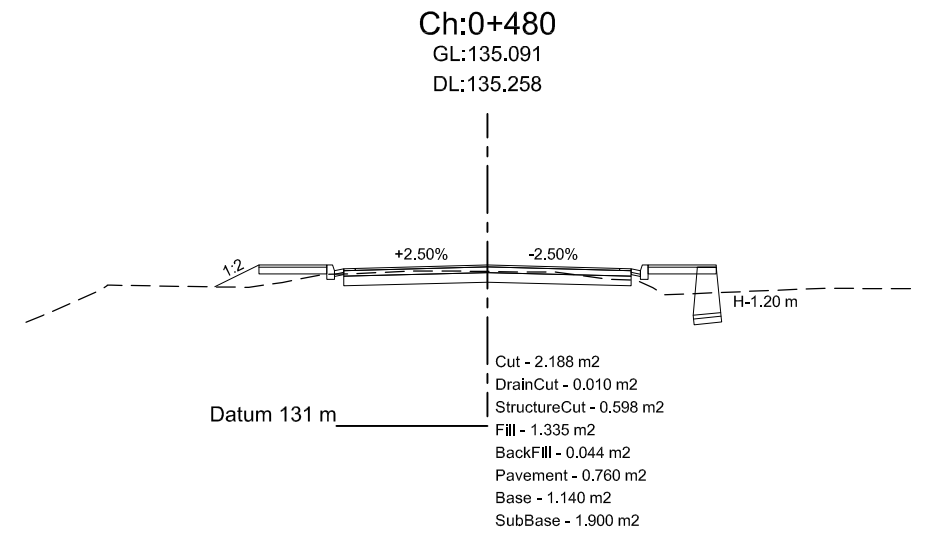
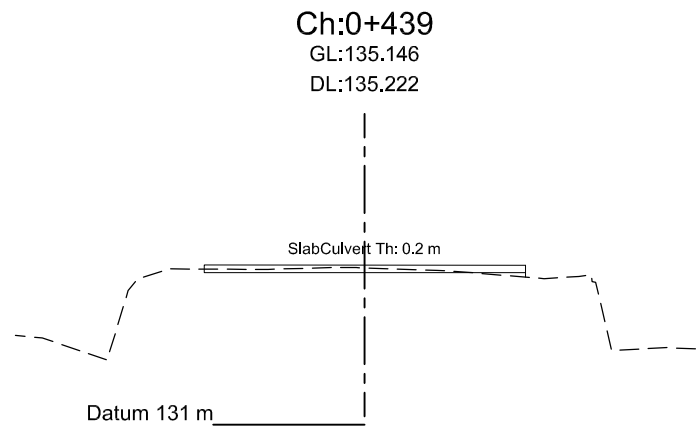
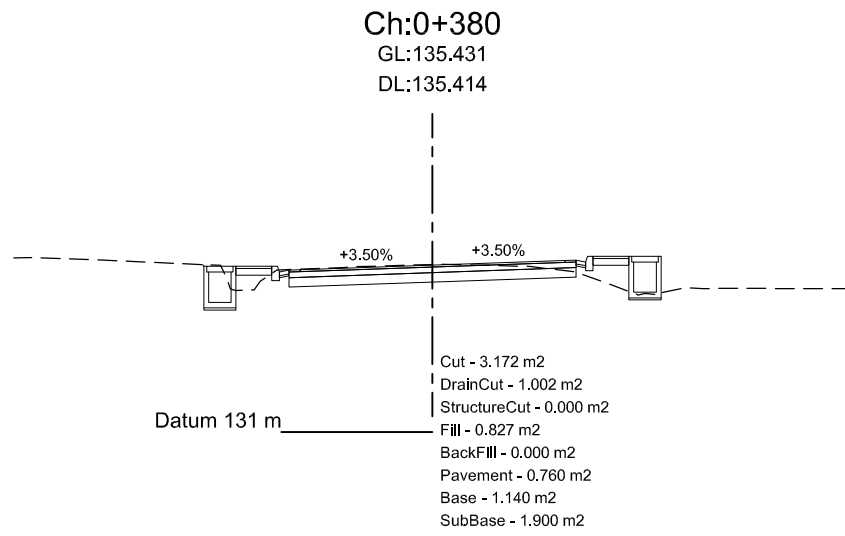

Department of Urban Development & Building Construction (DUDBC)
Regional Urban Development Project (RUDP)
West Urban Corridor (WUC) Development Project
Babarmahal, Kathmandu, Nepal

Reviewed & Designed By :
DOHWA Engineering Co. Ltd.
in Association with
ERMIC (P.) Ltd., SILT Consultants (P.) Ltd., and
DIGICON (P.) Ltd.
Mid- Baneshwor, Kathmandu
Tel: 01- 4589393

Consultant
Team Leader : YOO CHANGMIN
Reviewed By : YAGYA BAHADUR MALLA
Designed By : MANJU MUNANKARMI

Client
Approved By :
Checked By :

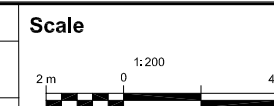

Cross-Section
BANCHAUKI-MAYADEVI PARK- MILDANDA
- BUDDHA CIRCUIT ROAD
CH 0+000 - 4+941.092 Km

REV : MAY 2024
DRG NO : DM/RD/CS/3
CHAINAGE : 0+340-0+480
SHEET NO : 3



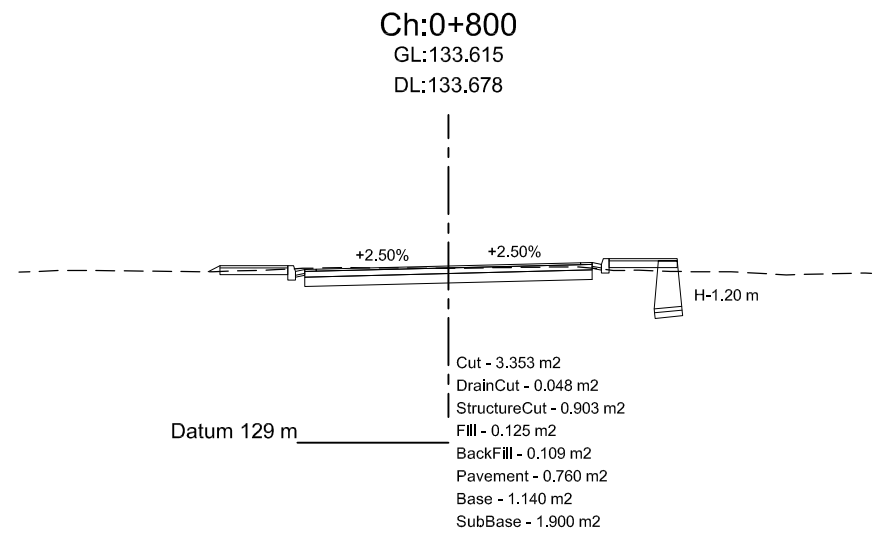
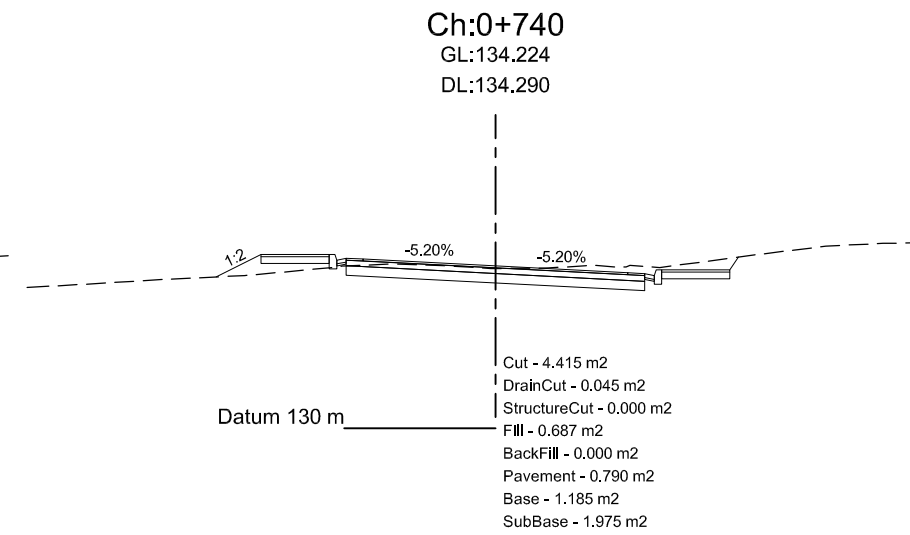
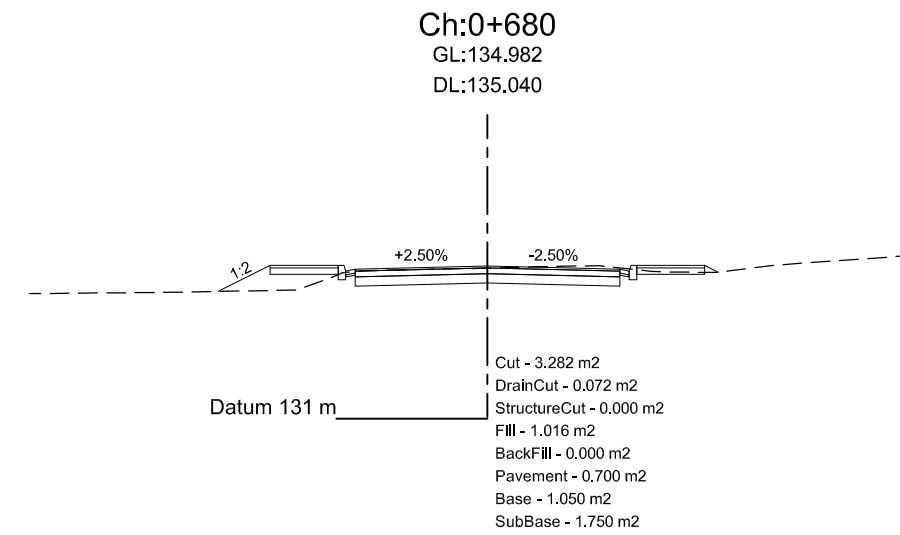
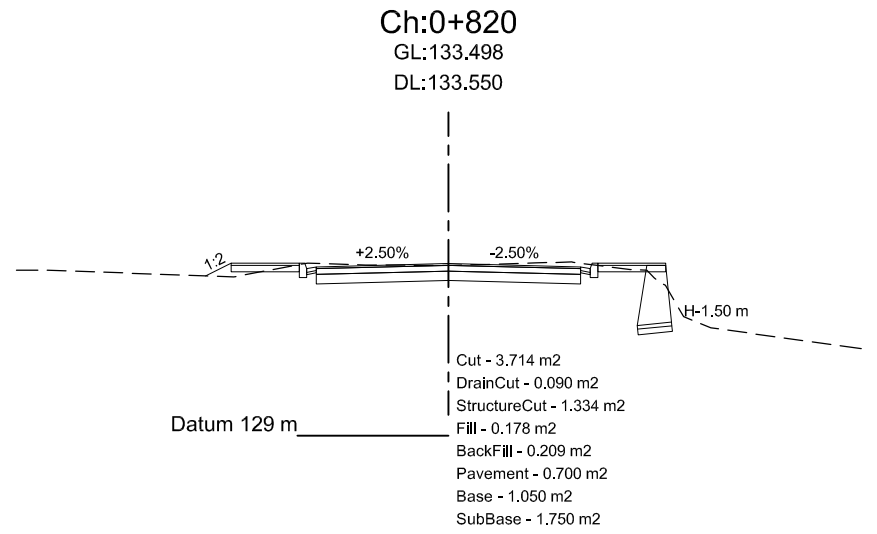
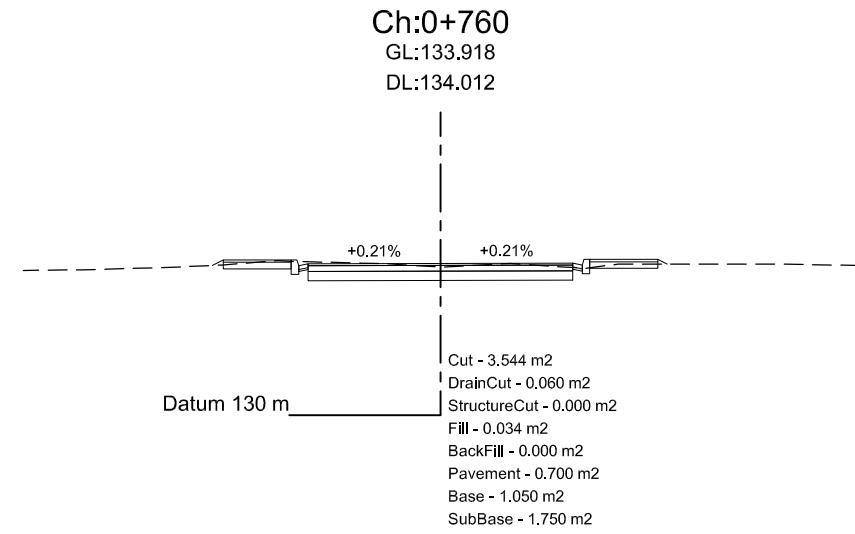
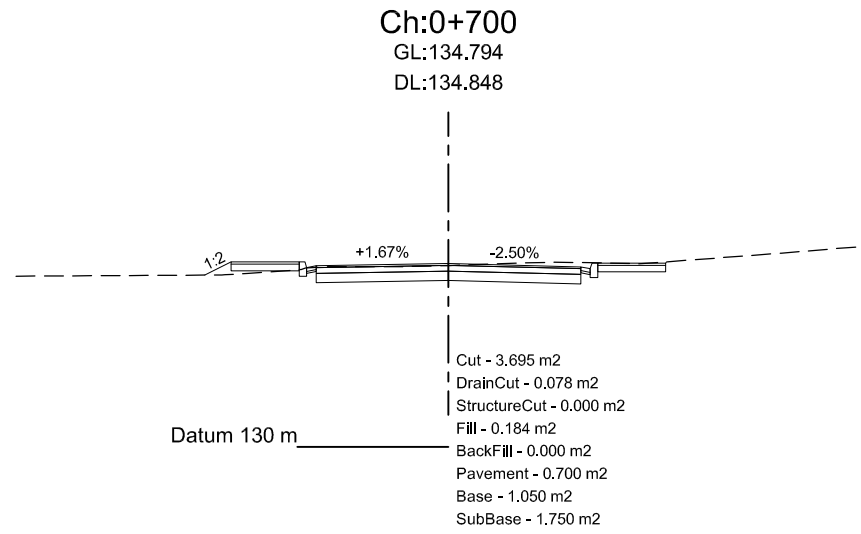
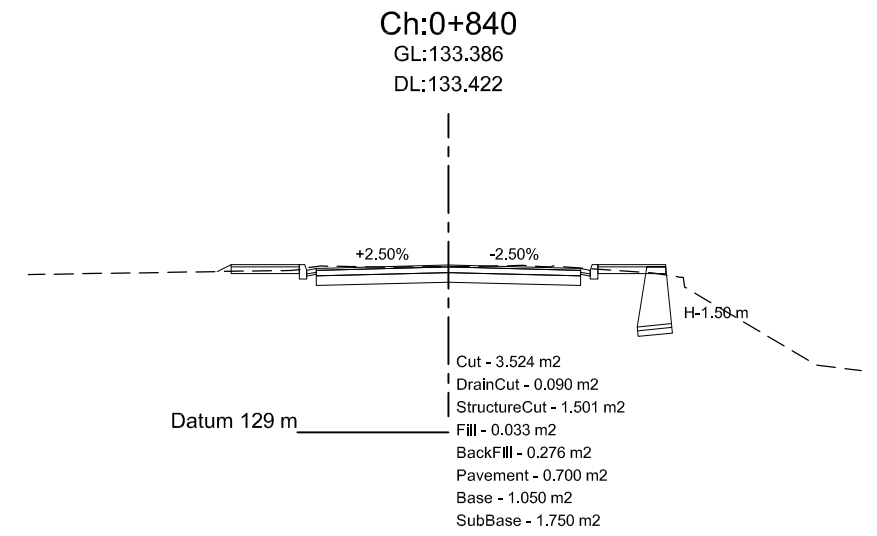
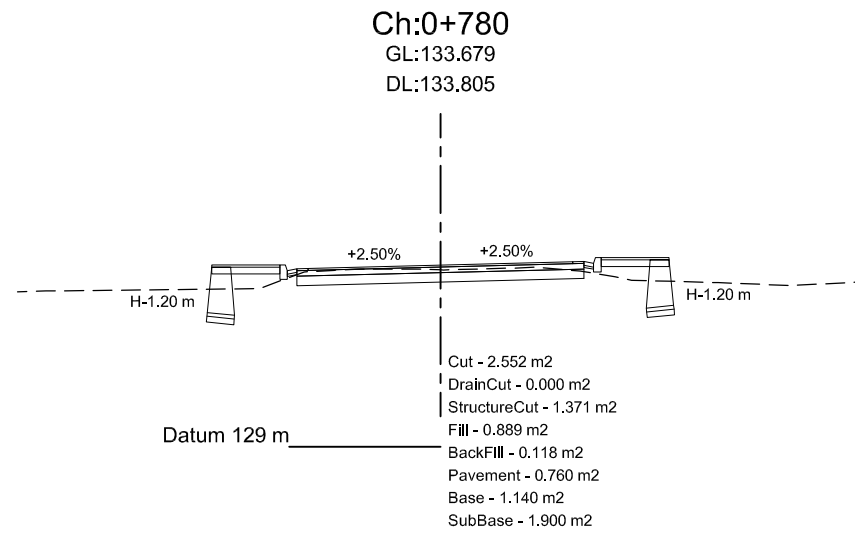
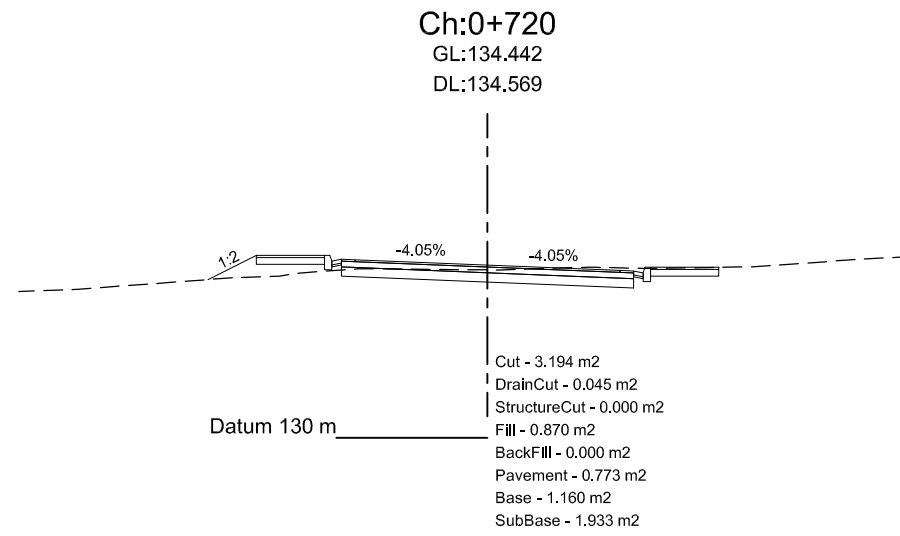

Department of Urban Development & Building Construction (DUDBC)
Regional Urban Development Project (RUDP)
West Urban Corridor (WUC) Development Project
Babarmahal, Kathmandu, Nepal

Reviewed & Designed By :
DOHWA Engineering Co. Ltd.
in Association with
ERMIC (P.) Ltd., SILT Consultants (P.) Ltd., and
DIGICON (P.) Ltd.
Mid- Baneshwor, Kathmandu
Tel: 01- 4589393

Consultant
Team Leader : YOO CHANGMIN
Reviewed By : YAGYA BAHADUR MALLA
Designed By : MANJU MUNANKARMI

Client
Approved By :
Checked By :

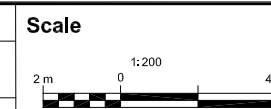

Cross-Section
BANCHAUKI-MAYADEVI PARK- MILDANDA
- BUDDHA CIRCUIT ROAD
CH 0+000 - 4+941.092 Km

REV : MAY 2024
DRG NO : DM/RD/CS/5
CHAINAGE : 0+680-0+840
SHEET NO : 5

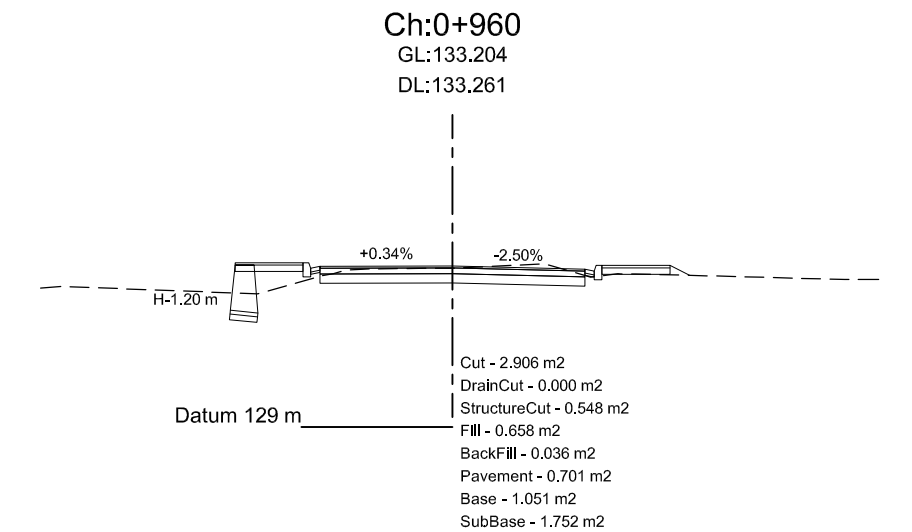
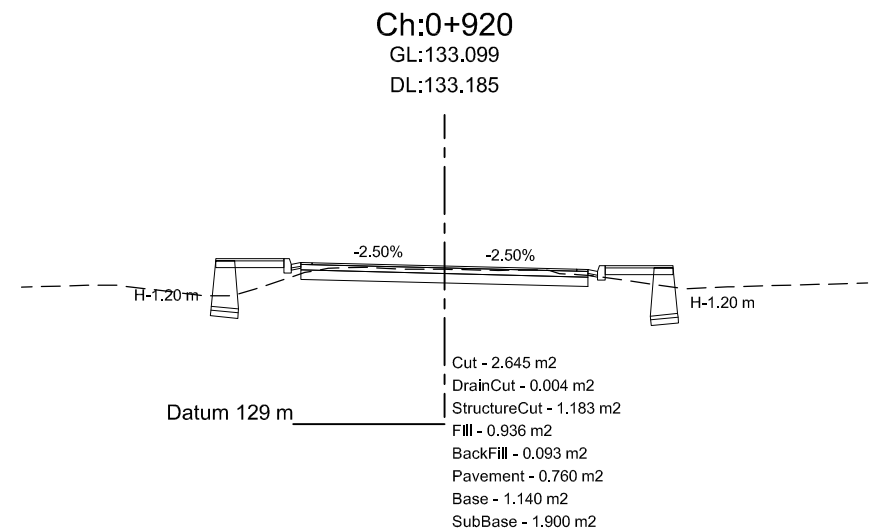
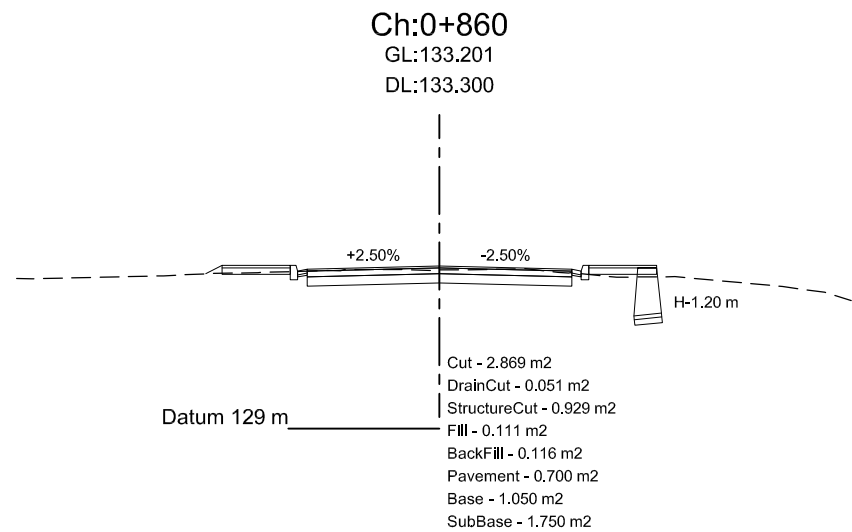
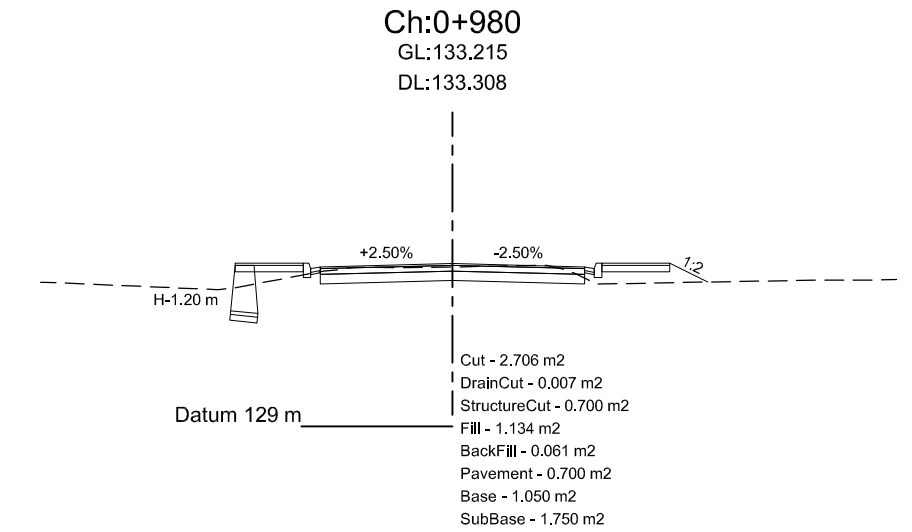
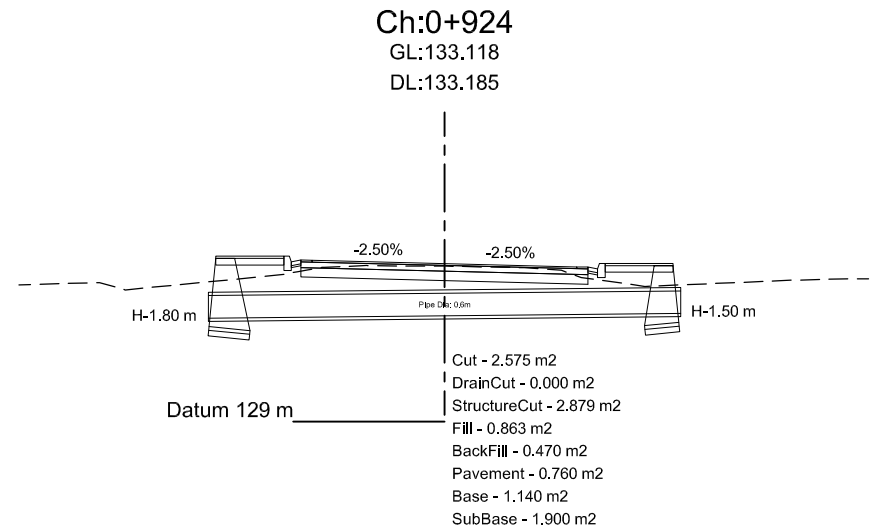
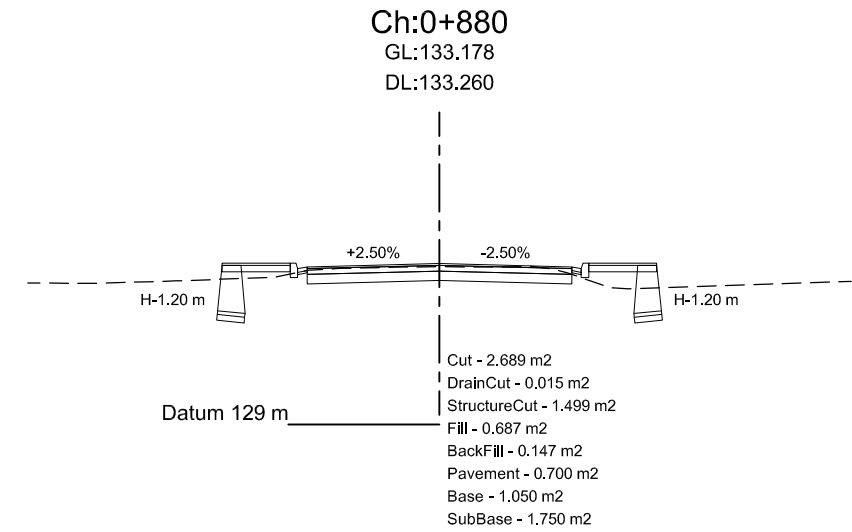
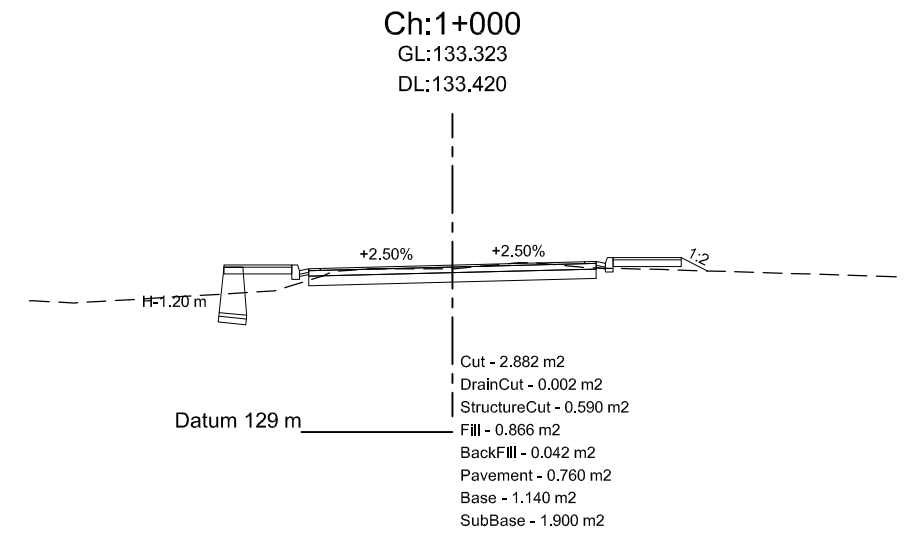
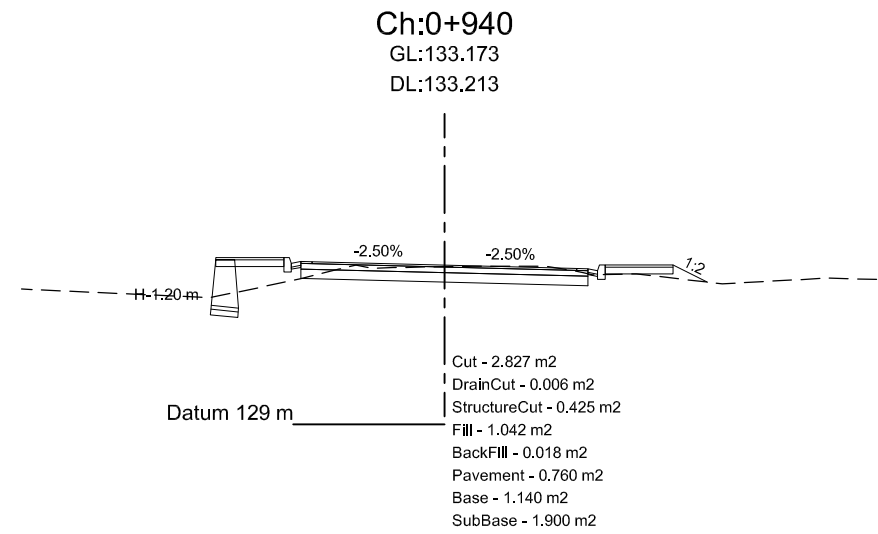
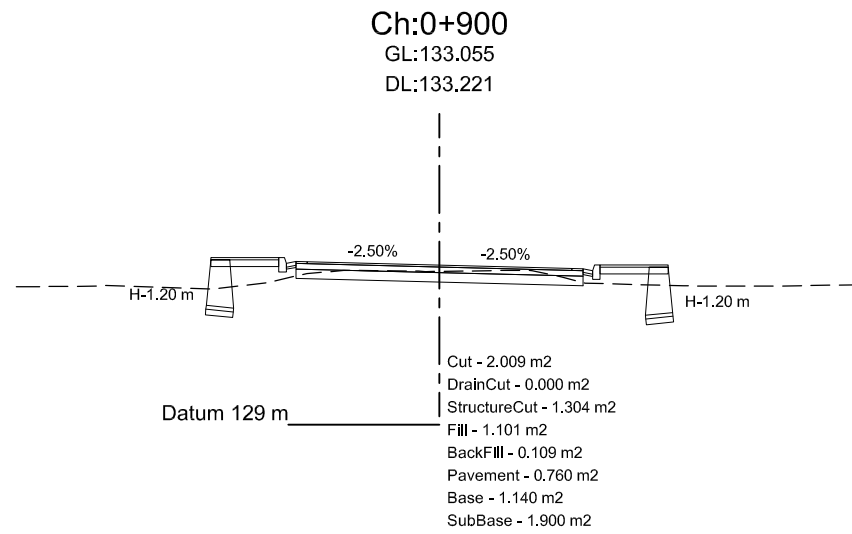

Department of Urban Development & Building
Construction (DUDBC)
Regional Urban Development Project (RUDP)
West Urban Corridor (WUC) Development Project
Babarmahal, Kathmandu, Nepal

Reviewed & Designed By :
DOHWA Engineering Co. Ltd.
in Association with
ERMIC (P.) Ltd., SILT Consultants (P.) Ltd., and
DIGICON (P.) Ltd.
Mid-Baneshwor, Kathmandu
Tel: 01-4589393

Consultant
Team Leader : YOO CHANGMIN
Reviewed By : YAGYA BAHADUR MALLA
Designed By : MANJU MUNANKARMI

Client
Approved By :
Checked By :

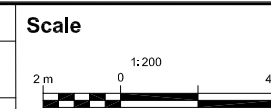

Cross-Section
BANCHAUKI-MAYADEVI PARK- MILDANDA
- BUDDHA CIRCUIT ROAD
CH 0+000 - 4+941.092 Km

REV : MAY 2024
DRG NO : DM/RD/CS/6
CHAINAGE : 0+860-1+000
SHEET NO : 6

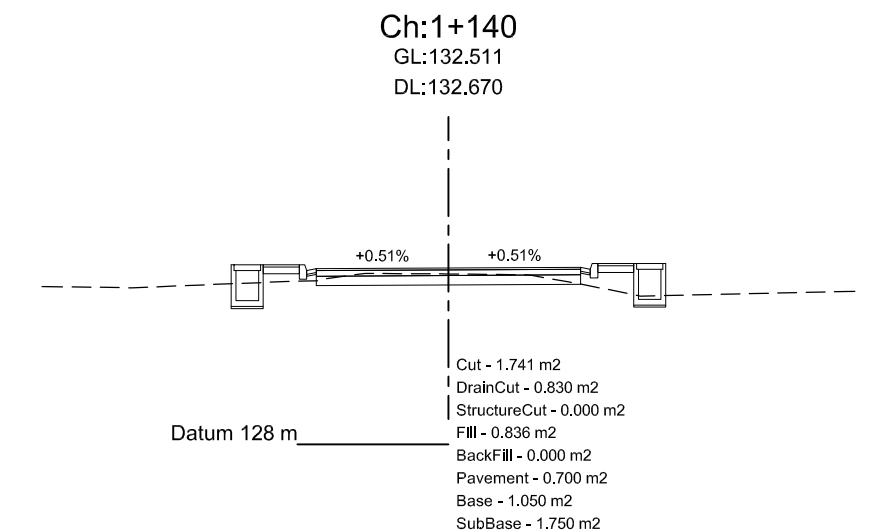
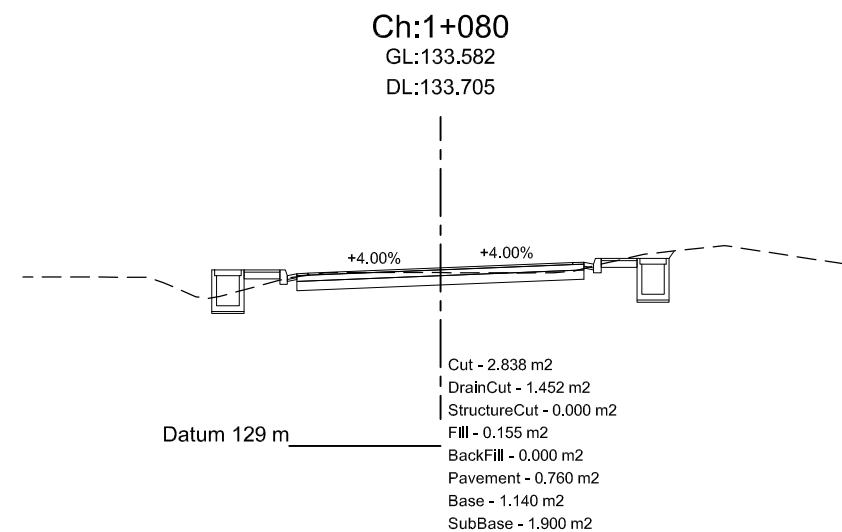
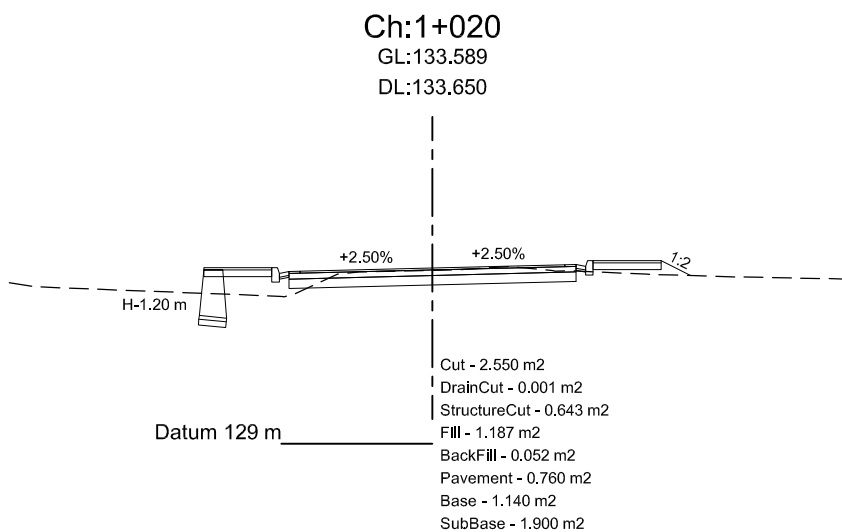
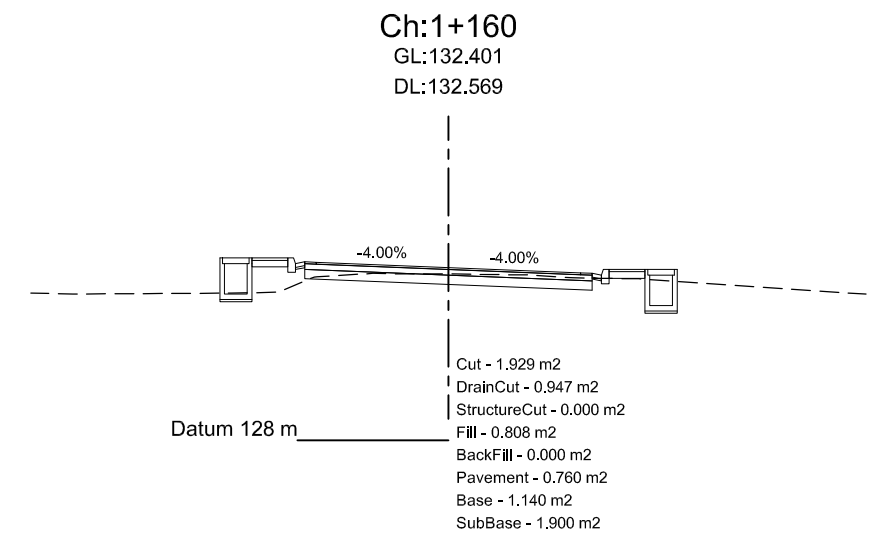
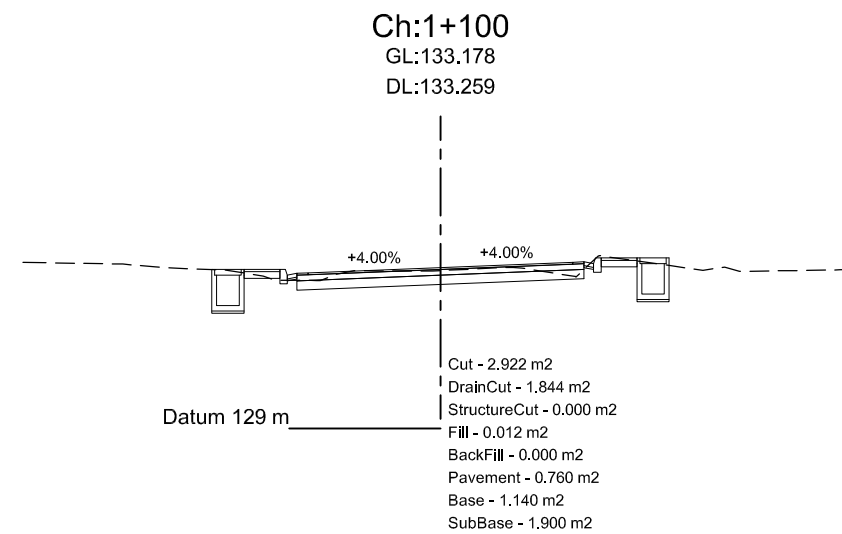
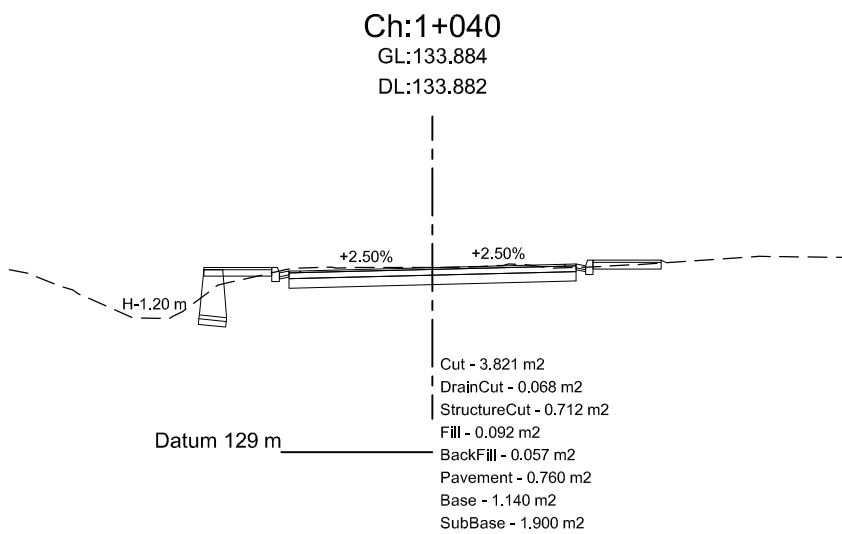
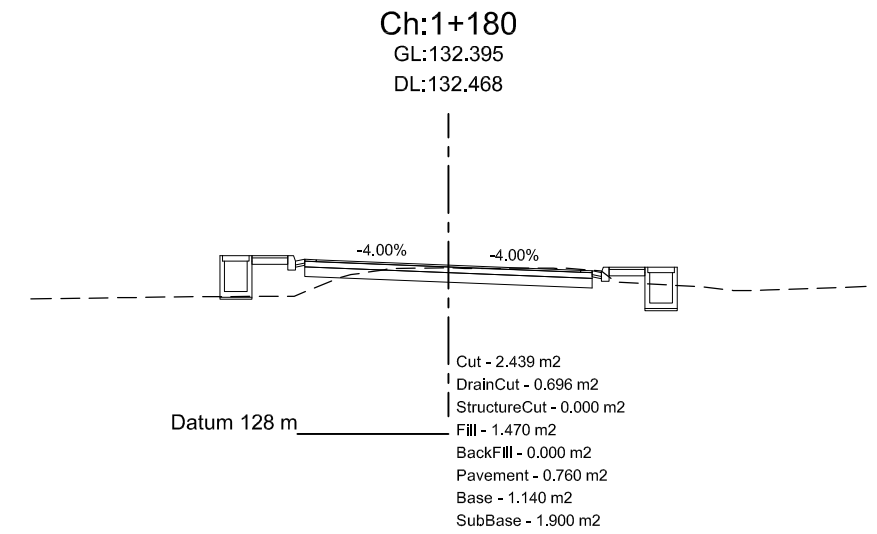
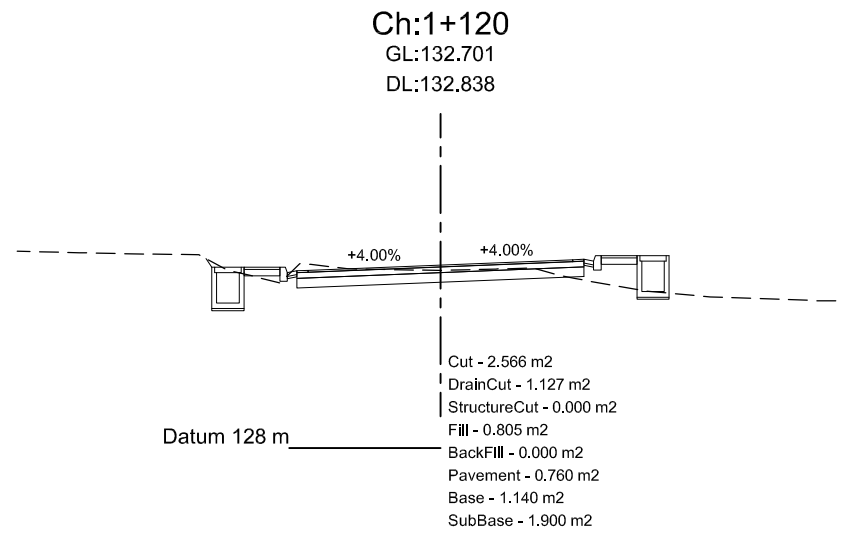
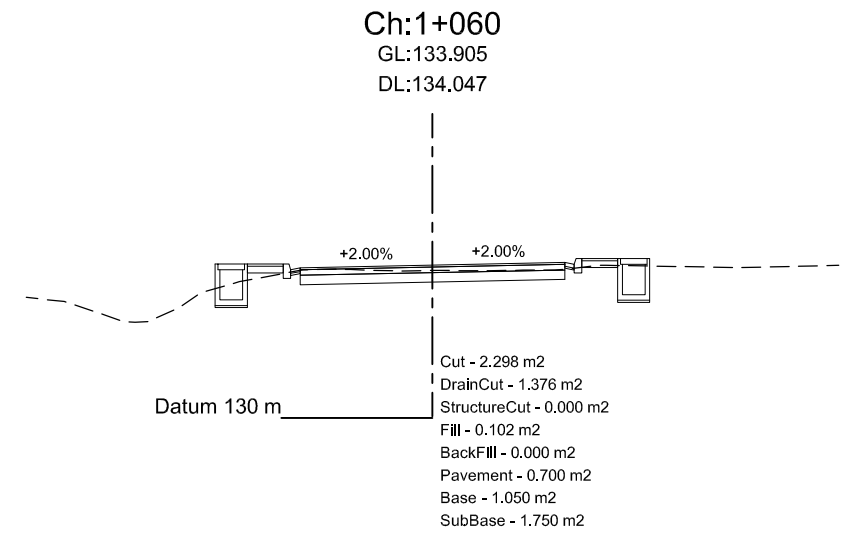

Department of Urban Development & Building
Construction (DUDBC)
Regional Urban Development Project (RUDP)
West Urban Corridor (WUC) Development Project
Babarmahal, Kathmandu, Nepal

Reviewed & Designed By :
DOHWA Engineering Co. Ltd.
in Association with
ERMIC (P.) Ltd., SILT Consultants (P.) Ltd., and
DIGICON (P.) Ltd.
Mid- Baneshwor, Kathmandu
Tel: 01-4589393

Consultant
Team Leader : YOO CHANGMIN
Reviewed By : YAGYA BAHADUR MALLA
Designed By : MANJU MUNANKARMI

Client
Approved By :
Checked By :

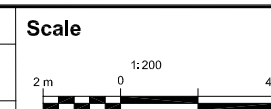

Cross-Section
BANCHAUKI-MAYADEVI PARK- MILDANDA
- BUDDHA CIRCUIT ROAD
CH 0+000 - 4+941.092 Km

REV : MAY 2024
DRG NO : DM/RD/CS/7
CHAINAGE : 1+020-1+180
SHEET NO : 7

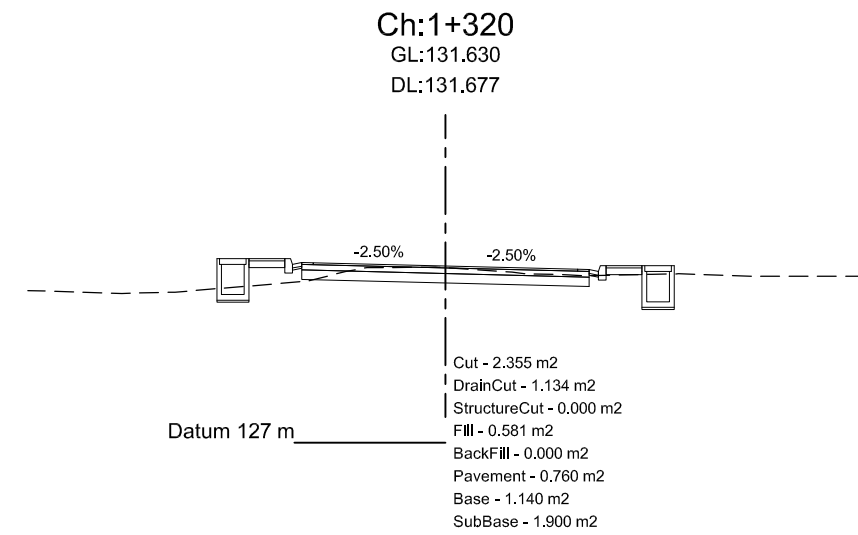
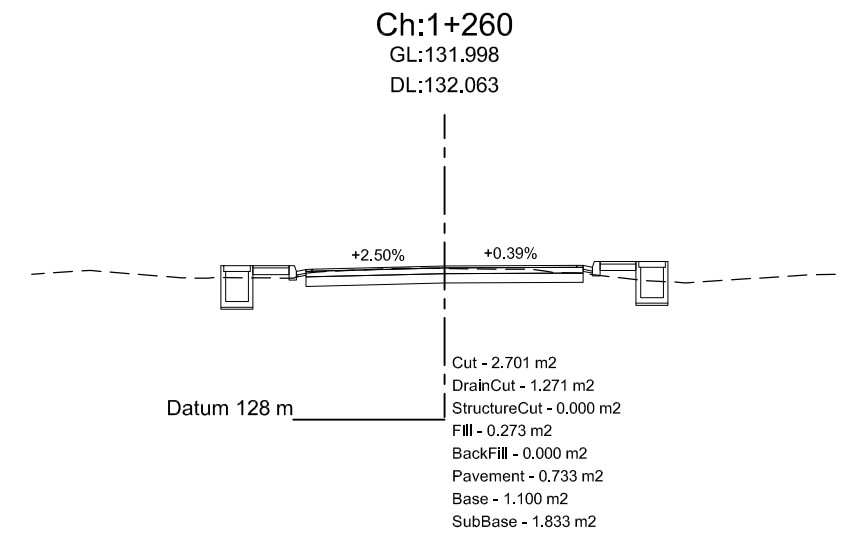
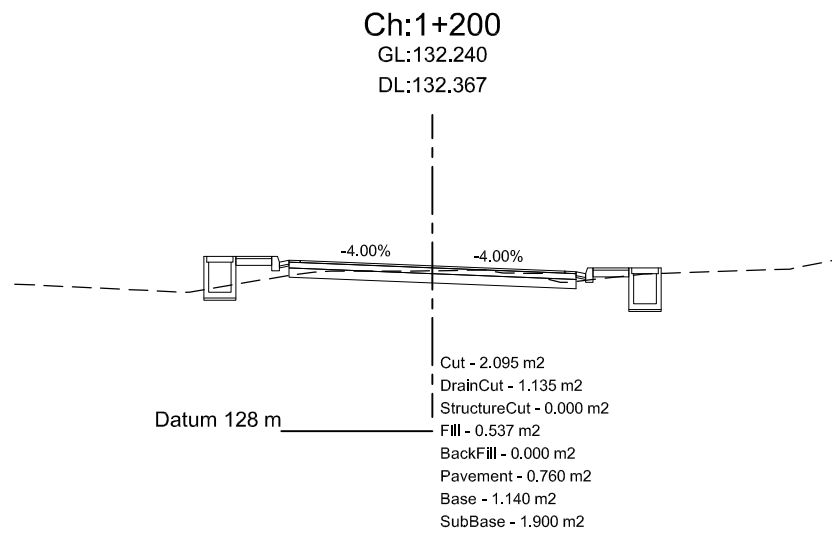
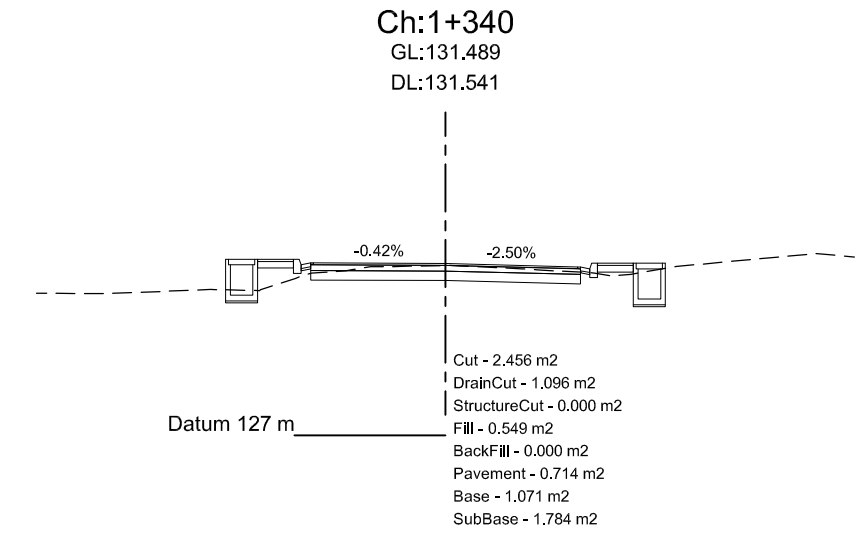
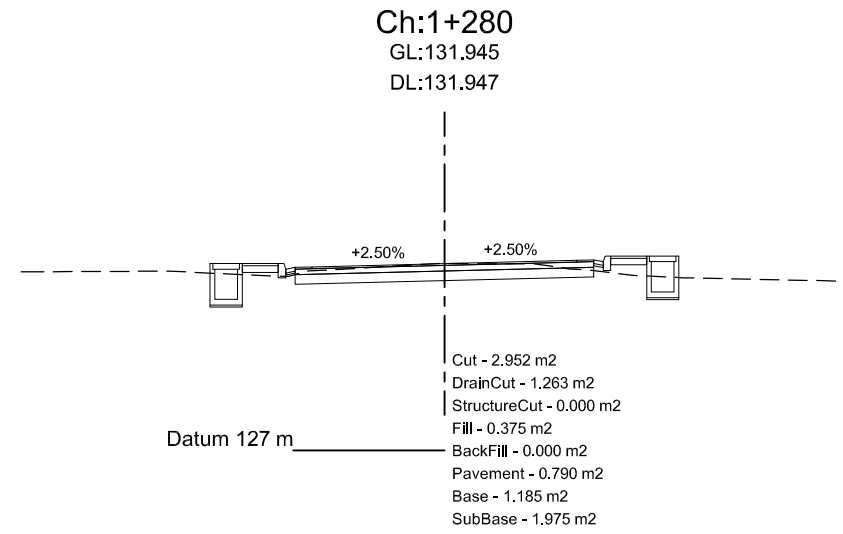
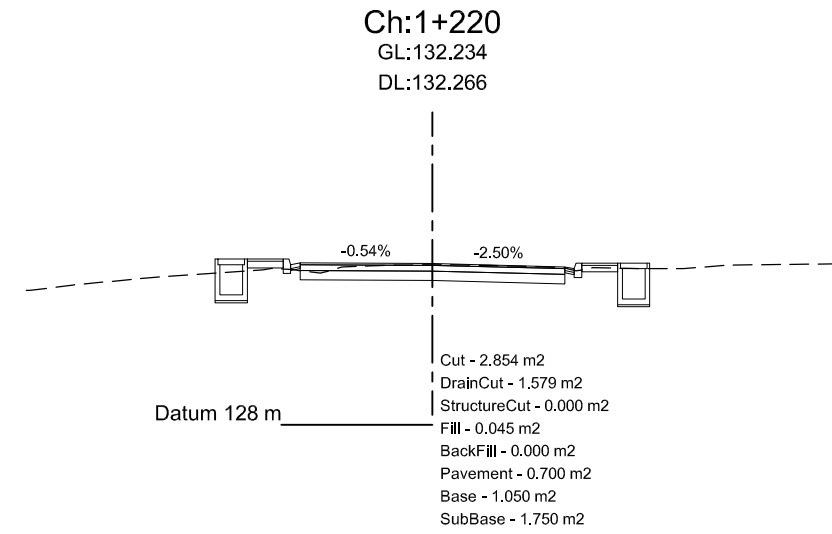
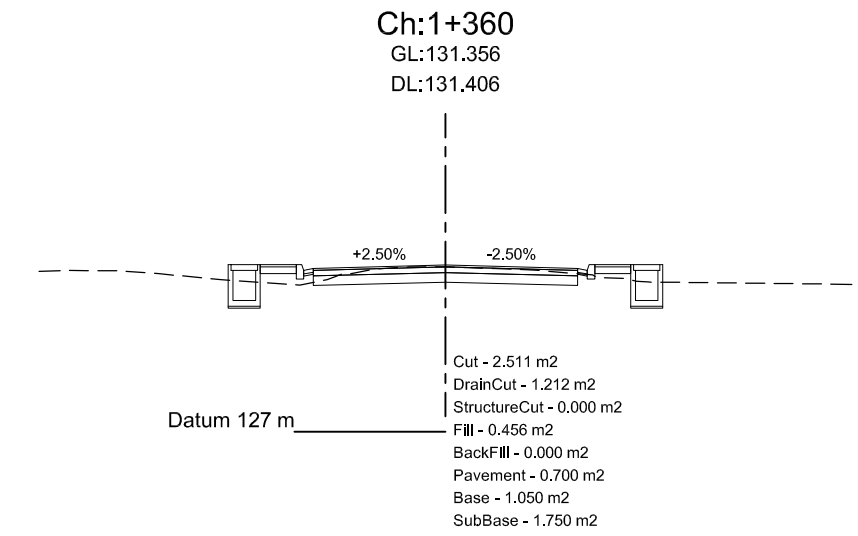
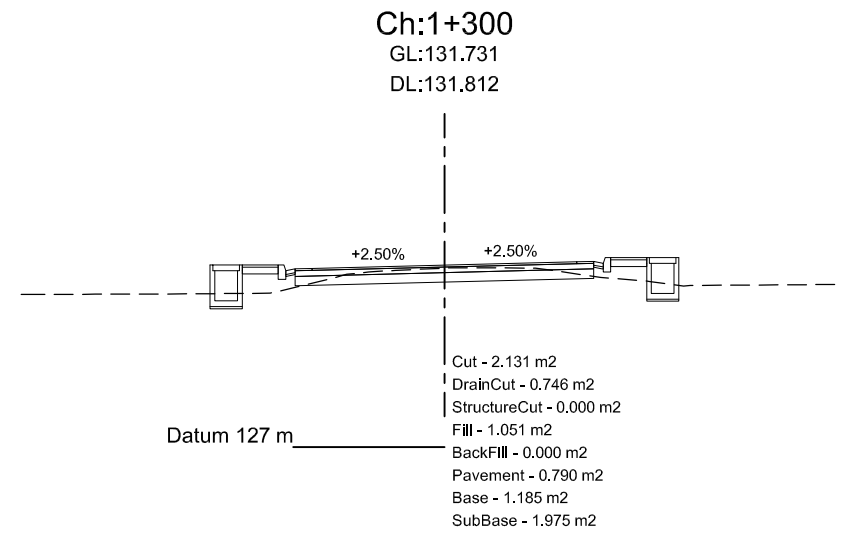
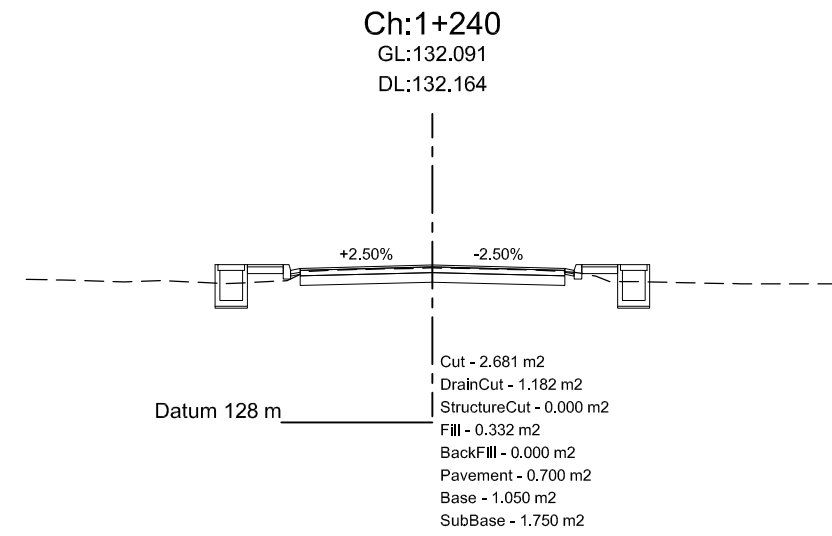

Department of Urban Development & Building Construction (DUDBC)
Regional Urban Development Project (RUDP)
West Urban Corridor (WUC) Development Project
Babarmahal, Kathmandu, Nepal

Reviewed & Designed By :
DOHWA Engineering Co. Ltd.
in Association with
ERMIC (P.) Ltd., SILT Consultants (P.) Ltd., and
DIGICON (P.) Ltd.
Mid- Baneshwor, Kathmandu
Tel: 01- 4589393

Consultant
Team Leader : YOO CHANGMIN
Reviewed By : YAGYA BAHADUR MALLA
Designed By : MANJU MUNANKARMI

Client
Approved By :
Checked By :

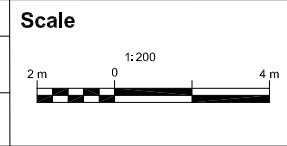

Cross-Section
BANCHAUKI-MAYADEVI PARK- MILDANDA
- BUDDHA CIRCUIT ROAD
CH 0+000 - 4+941.092 Km

REV : MAY 2024
DRG NO : DM/RD/CS/8
CHAINAGE : 1+200-1+360
SHEET NO : 8

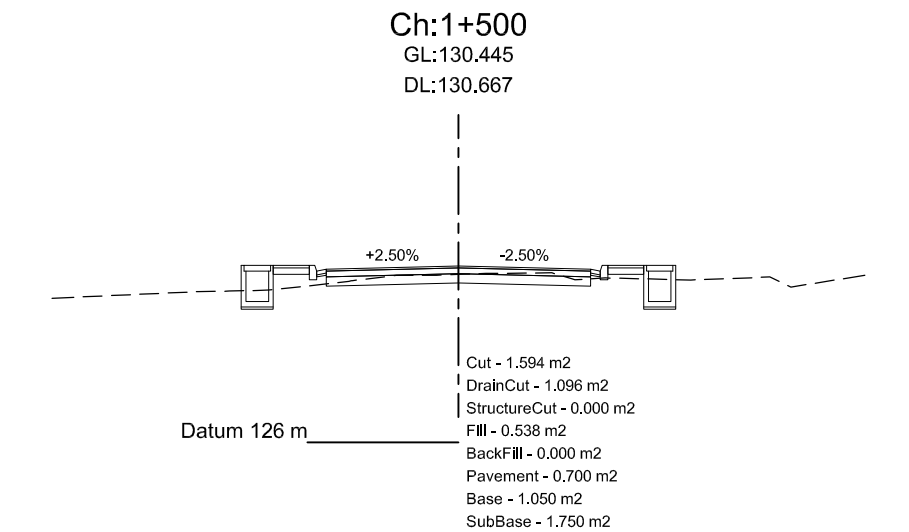
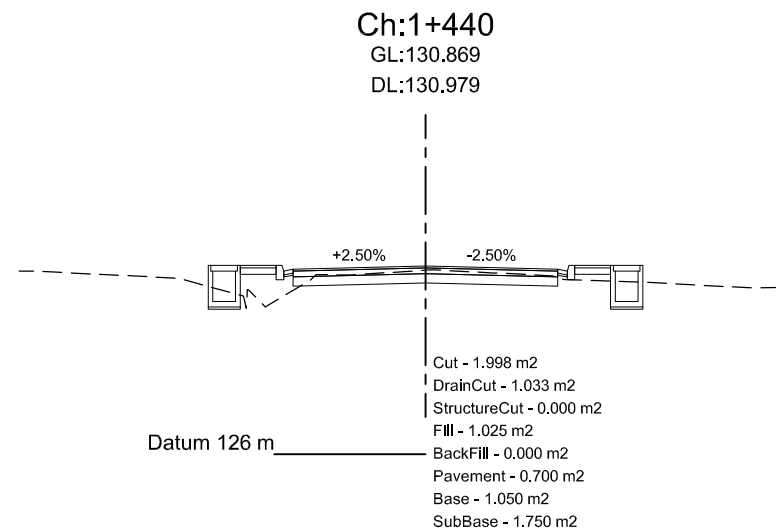
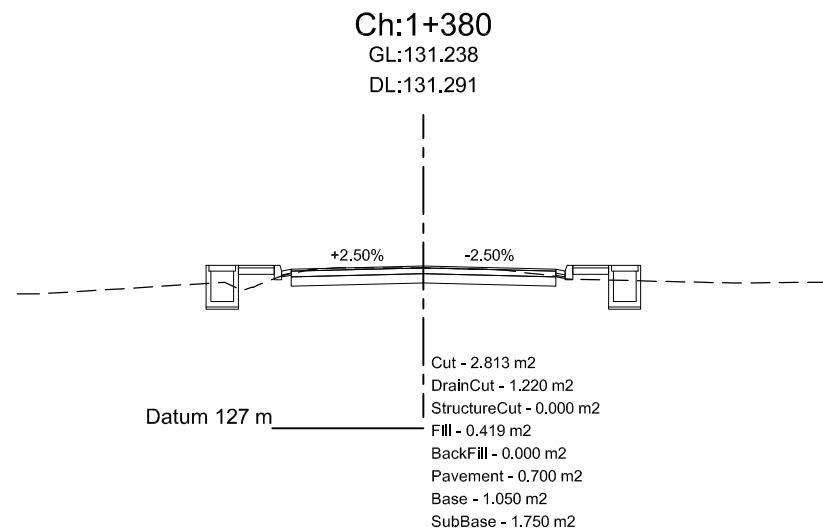
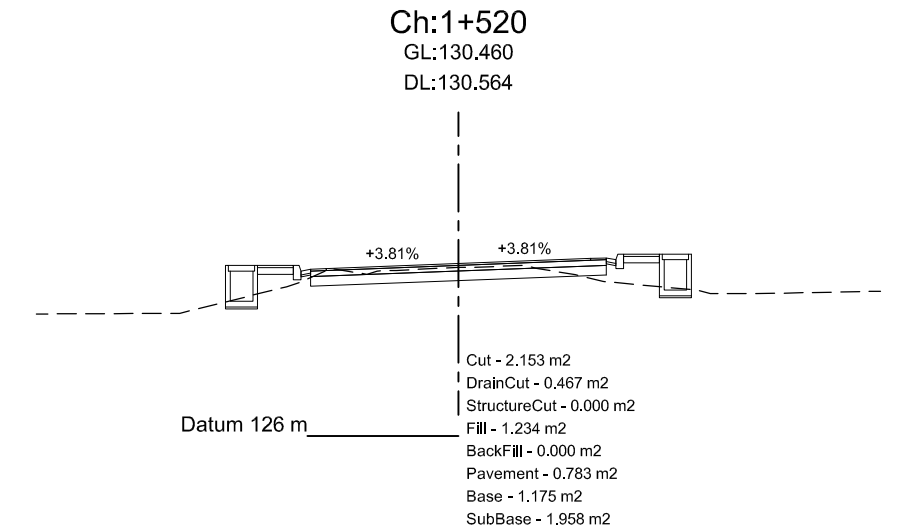
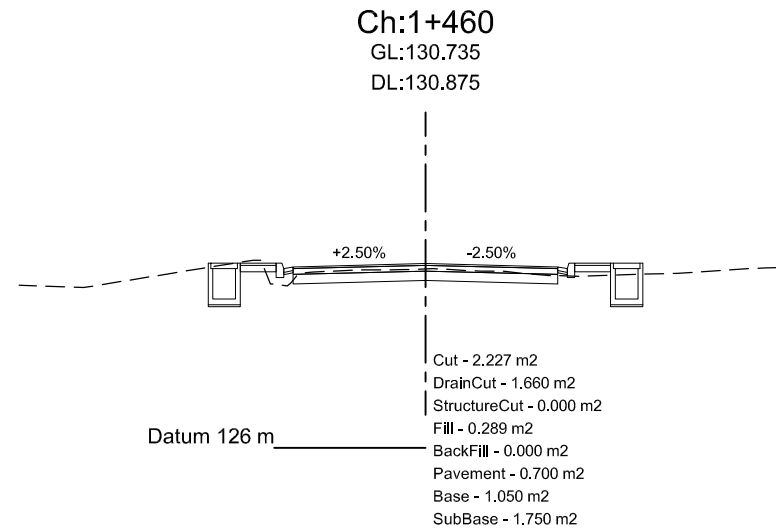
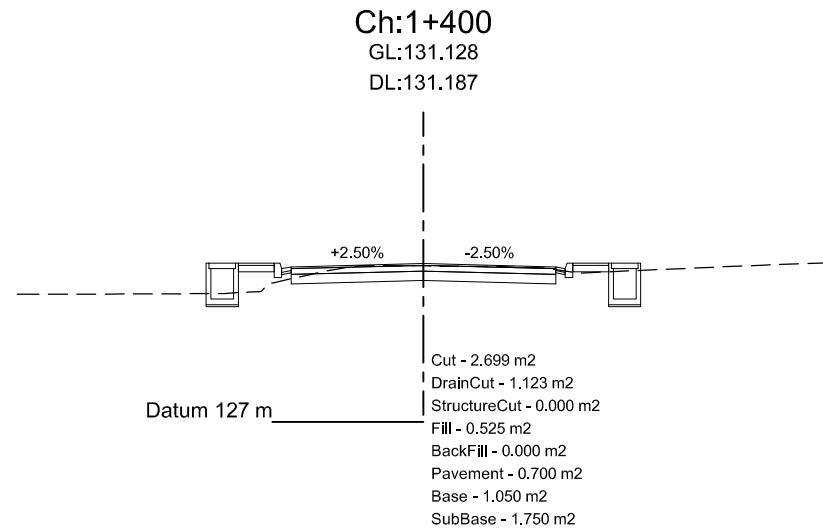
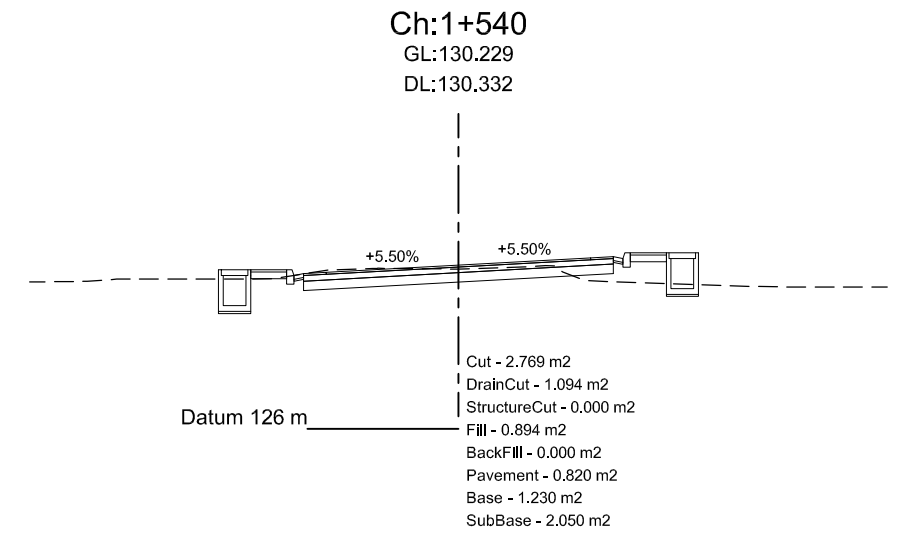
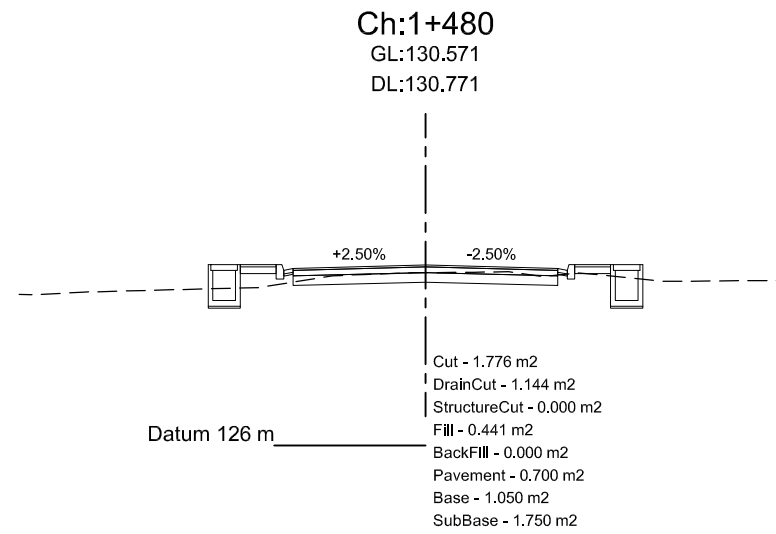
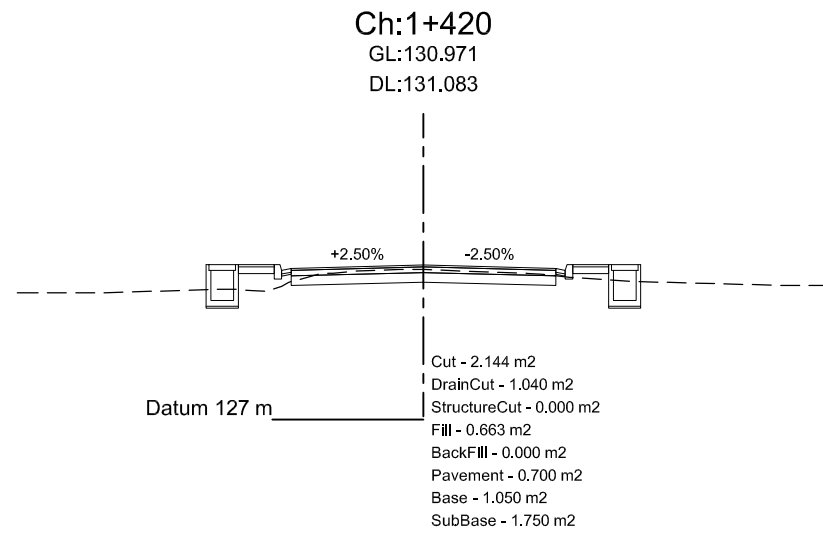

Department of Urban Development & Building
Construction (DUDBC)
Regional Urban Development Project (RUDP)
West Urban Corridor (WUC) Development Project
Babarmahal, Kathmandu, Nepal

Reviewed & Designed By :
DOHWA Engineering Co. Ltd.
in Association with
ERMIC (P.) Ltd., SILT Consultants (P.) Ltd., and
DIGICON (P.) Ltd.
Mid- Baneshwor, Kathmandu
Tel: 01- 4589393

Consultant
Team Leader : YOO CHANGMIN
Reviewed By : YAGYA BAHADUR MALLA
Designed By : MANJU MUNANKARMI

Client
Approved By :
Checked By :

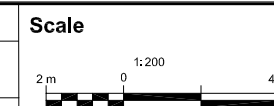

Cross-Section
BANCHAUKI-MAYADEVI PARK- MILDANDA
- BUDDHA CIRCUIT ROAD
CH 0+000 - 4+941.092 Km

REV : MAY 2024
DRG NO : DM/RD/CS/9
CHAINAGE : 1+380-1+540
SHEET NO : 9

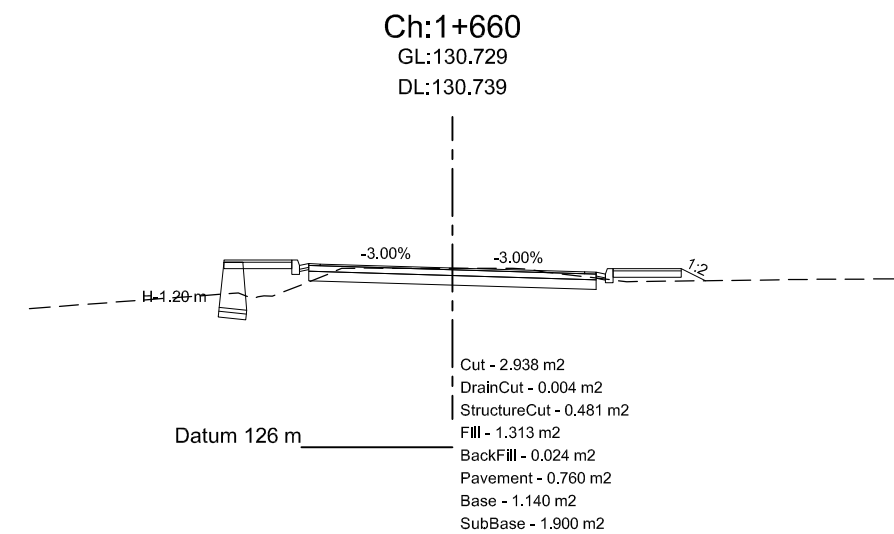
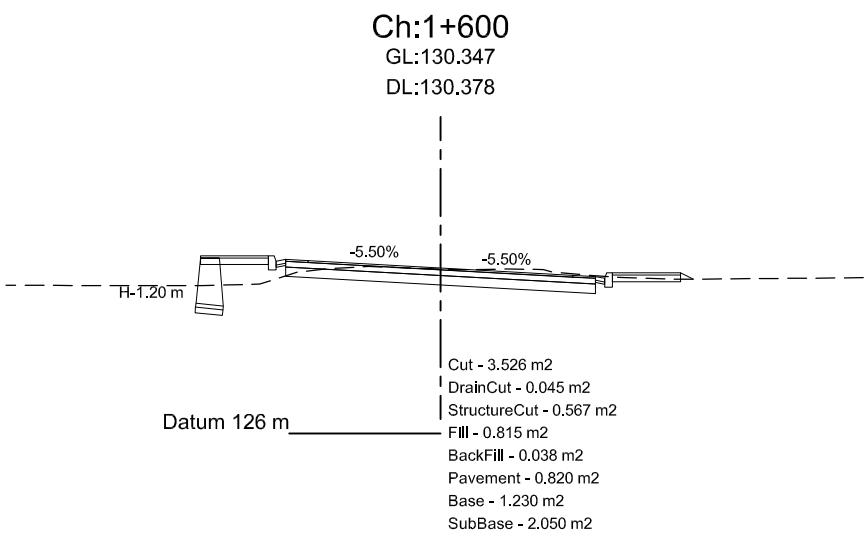
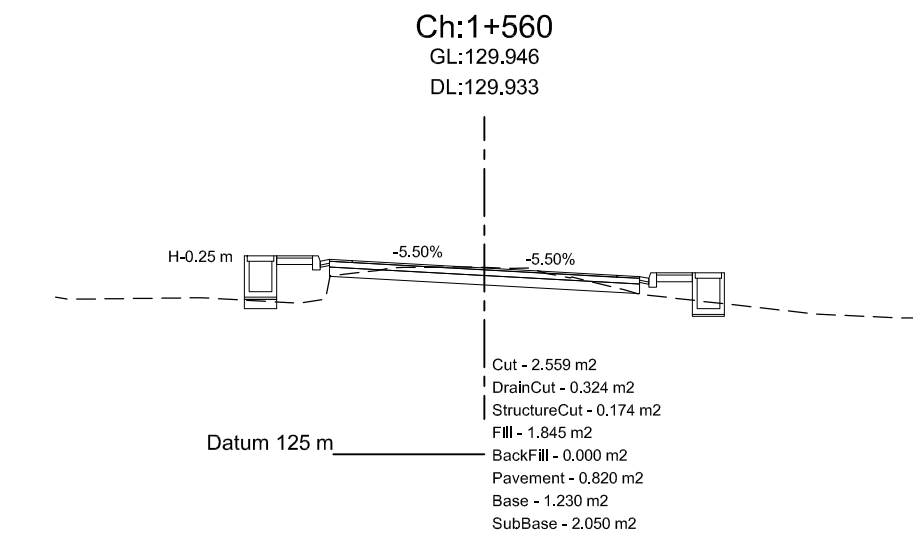
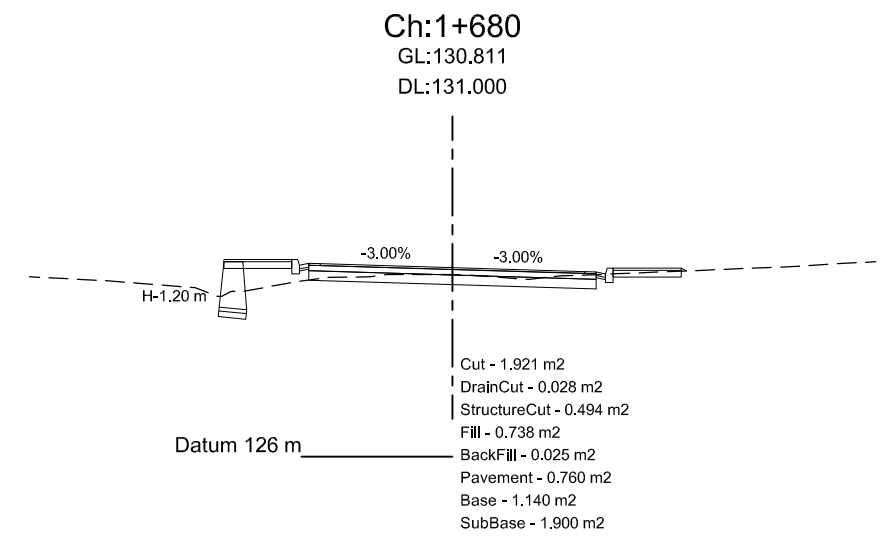
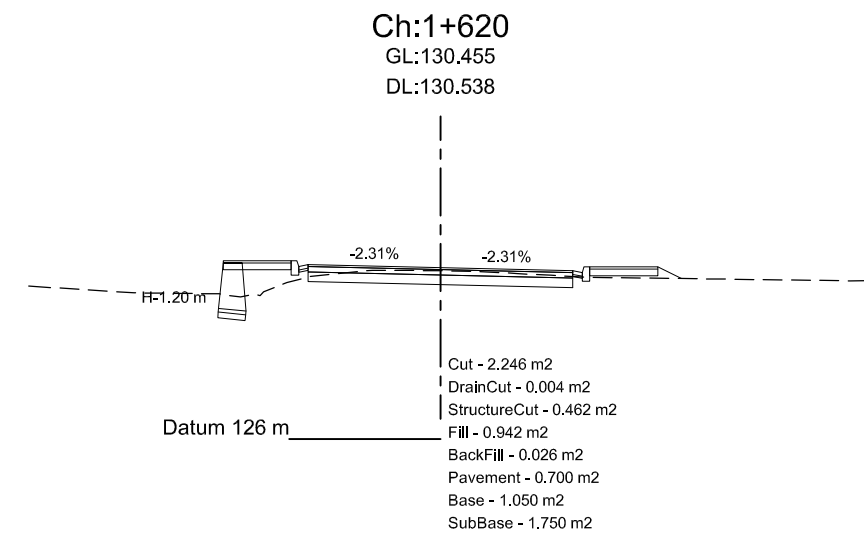
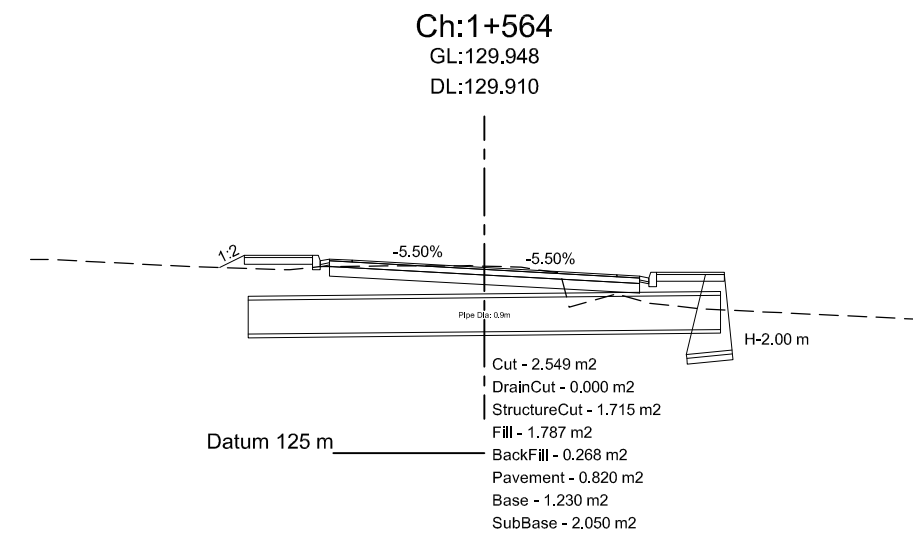
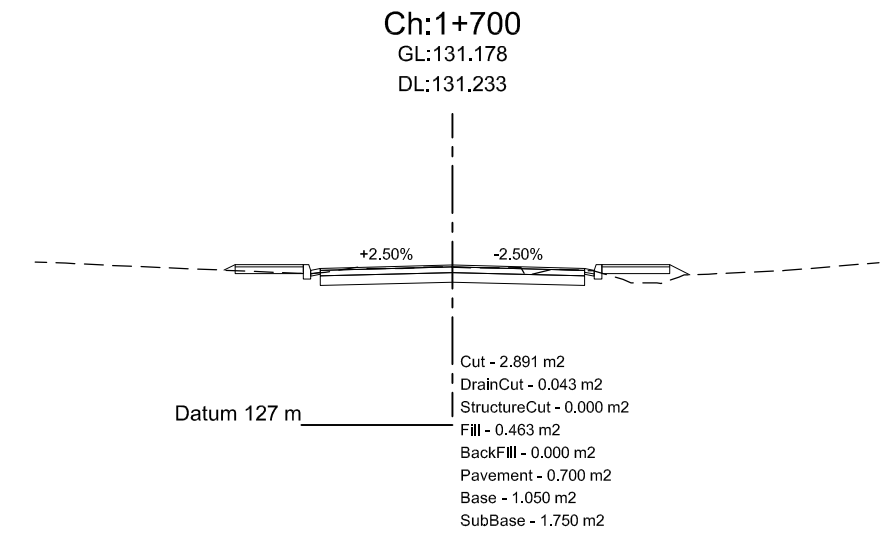
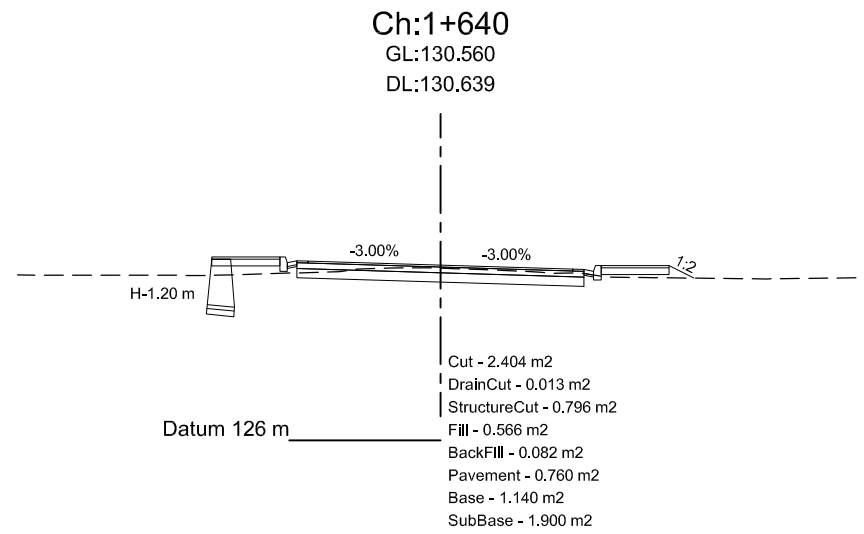
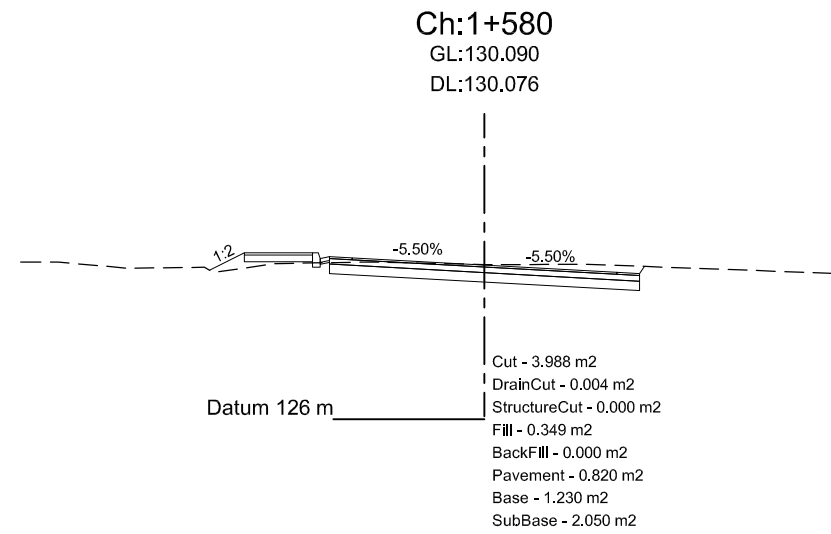

Department of Urban Development & Building
Construction (DUDBC)
Regional Urban Development Project (RUDP)
West Urban Corridor (WUC) Development Project
Babarmahal, Kathmandu, Nepal

Reviewed & Designed By :
DOHWA Engineering Co. Ltd.
in Association with
ERMIC (P.) Ltd., SILT Consultants (P.) Ltd., and
DIGICON (P.) Ltd.
Mid- Baneshwor, Kathmandu
Tel: 01- 4589393

Consultant
Team Leader : YOO CHANGMIN
Reviewed By : YAGYA BAHADUR MALLA
Designed By : MANJU MUNANKARMI

Client
Approved By :
Checked By :

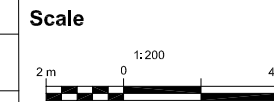

Cross-Section
BANCHAUKI-MAYADEVI PARK- MILDANDA
- BUDDHA CIRCUIT ROAD
CH 0+000 - 4+941.092 Km

REV : MAY 2024
DRG NO : DM/RD/CS/10
CHAINAGE : 1+560-1+700
SHEET NO : 10

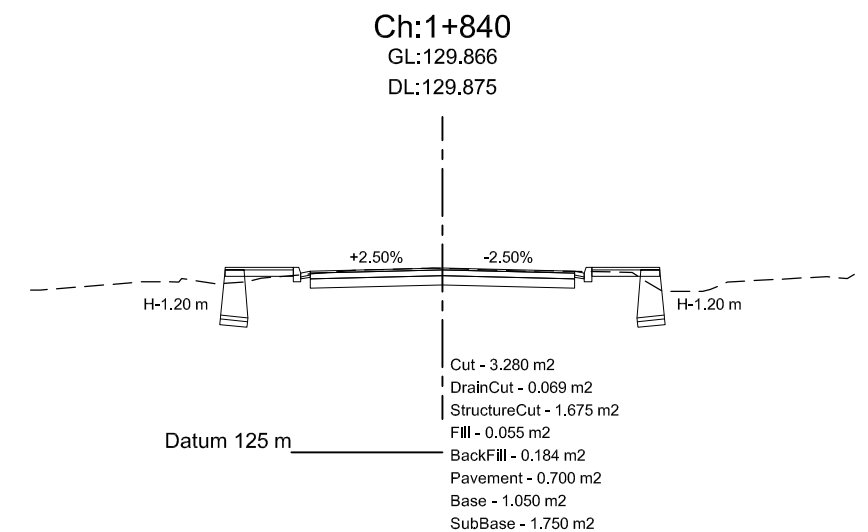
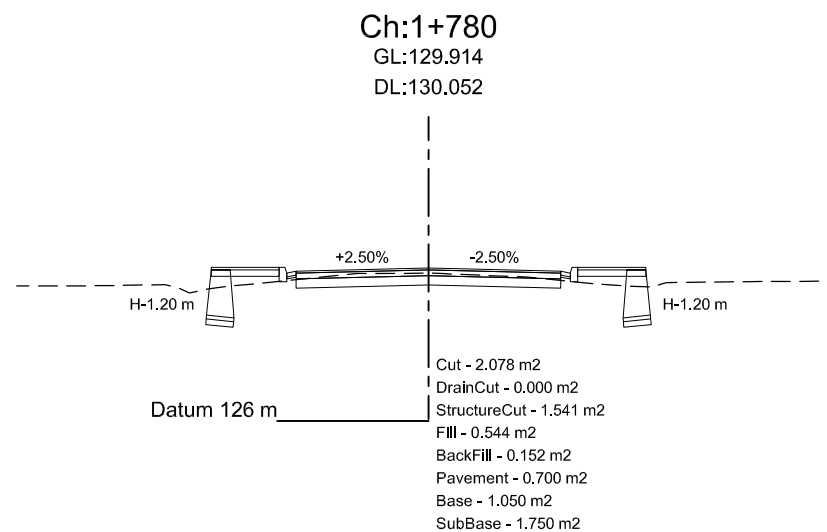
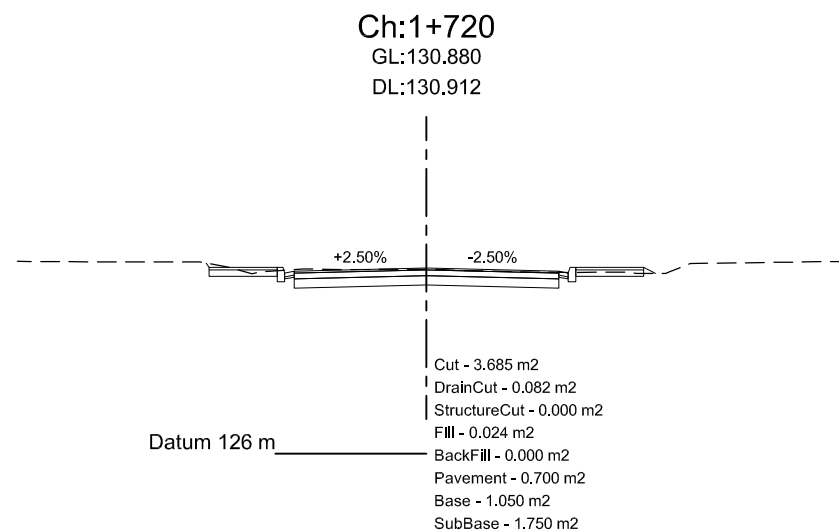
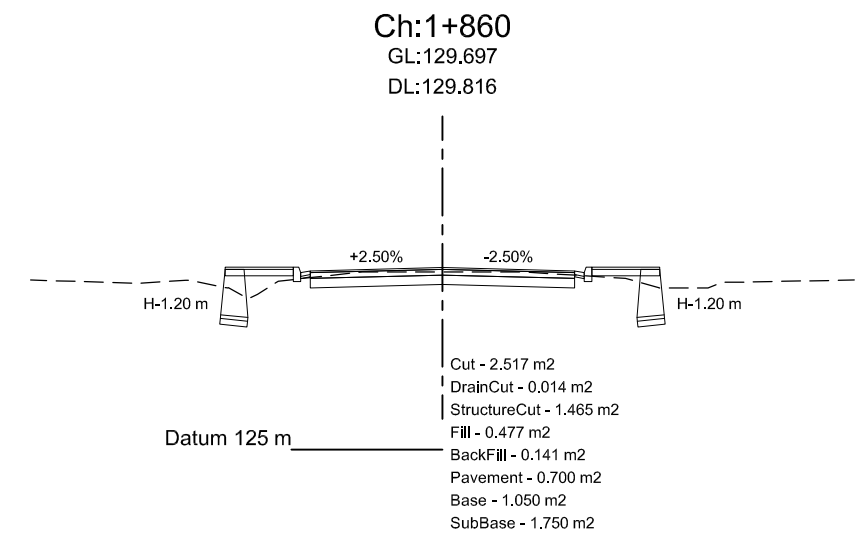
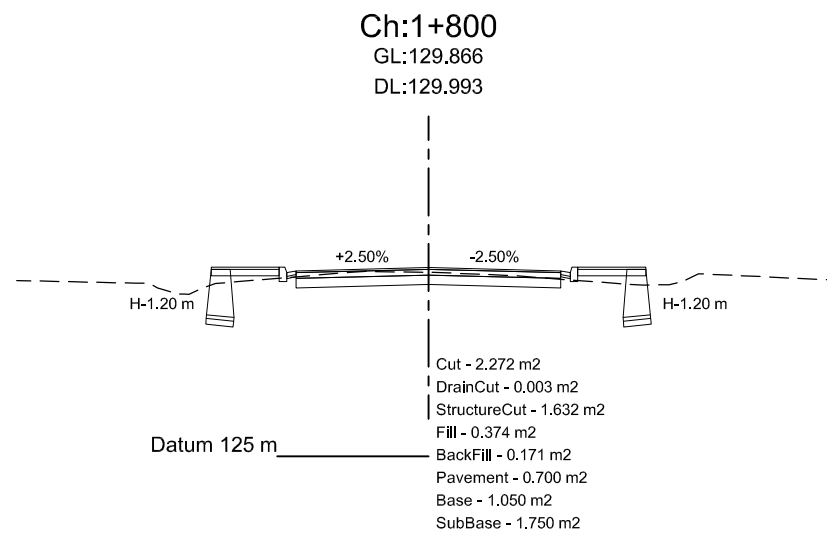
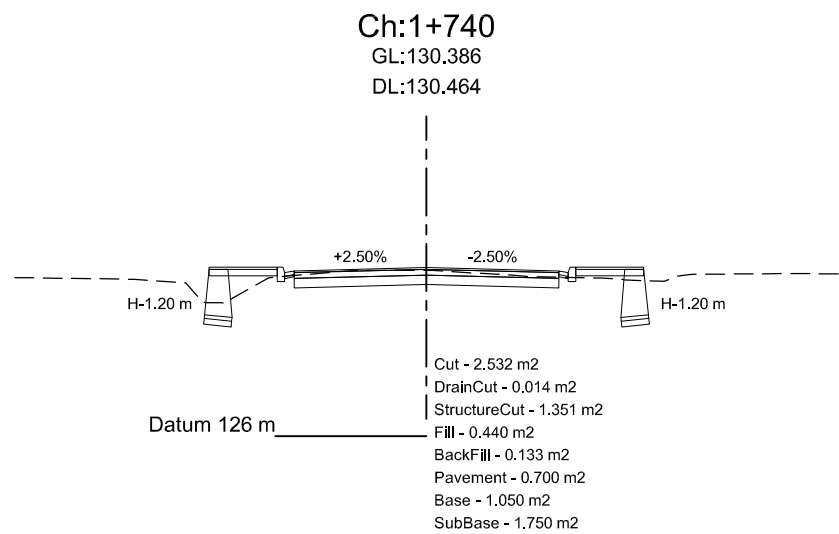
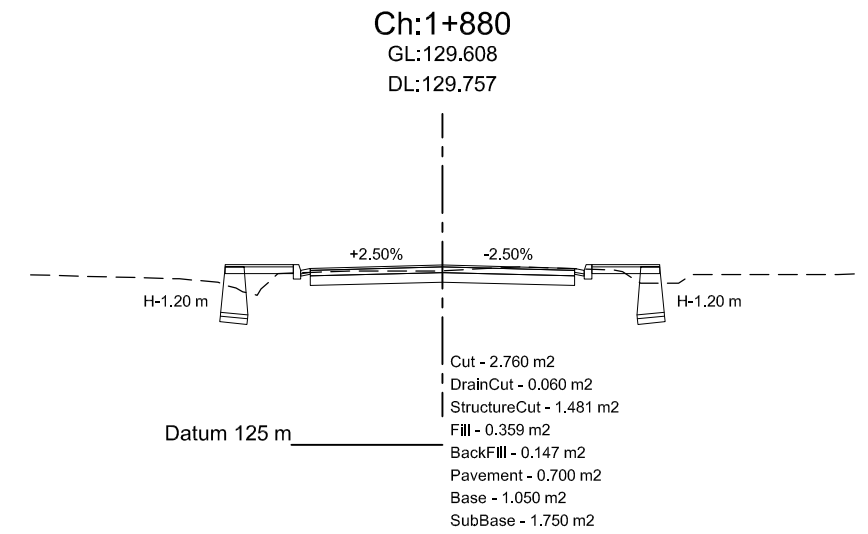
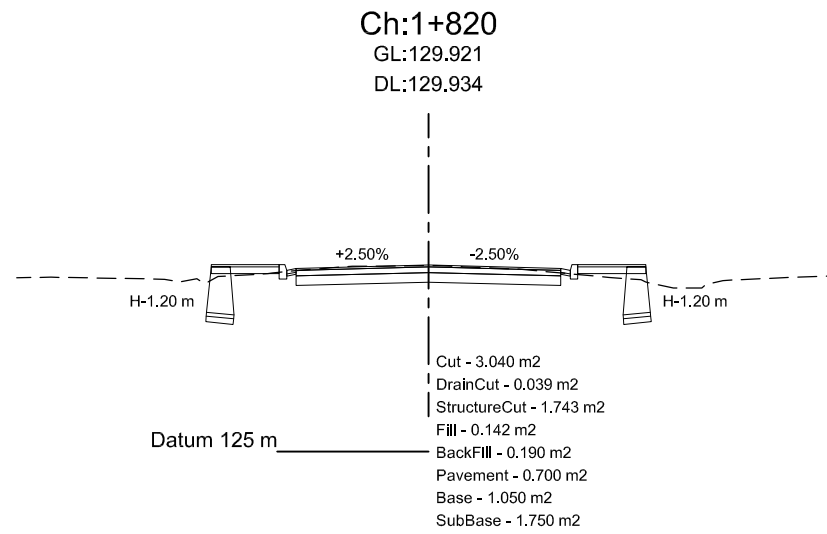
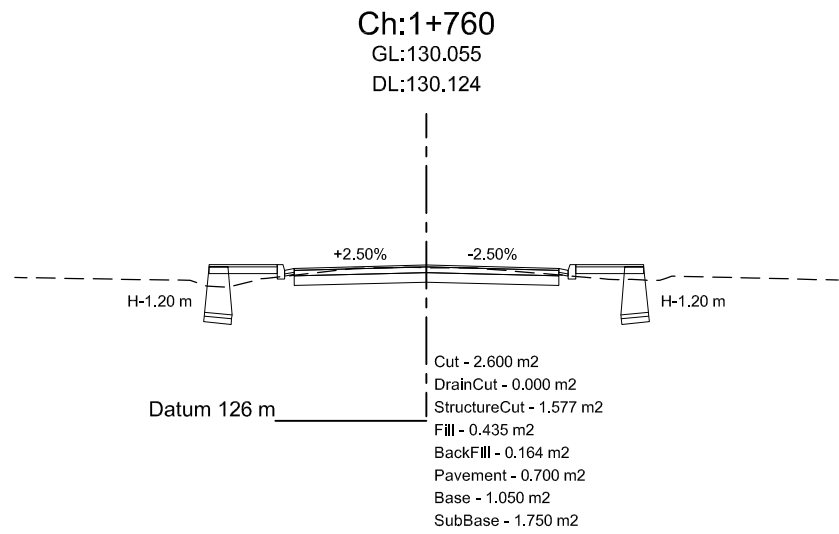

Department of Urban Development & Building Construction (DUDBC)
Regional Urban Development Project (RUDP)
West Urban Corridor (WUC) Development Project
Babarmahal, Kathmandu, Nepal

Reviewed & Designed By :
DOHWA Engineering Co. Ltd.
in Association with
ERMIC (P.) Ltd., SILT Consultants (P.) Ltd., and
DIGICON (P.) Ltd.
Mid- Baneshwor, Kathmandu
Tel: 01- 4589393

Consultant
Team Leader : YOO CHANGMIN
Reviewed By : YAGYA BAHADUR MALLA
Designed By : MANJU MUNANKARMI

Client
Approved By :
Checked By :

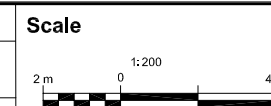

Cross-Section
BANCHAUKI-MAYADEVI PARK- MILDANDA
- BUDDHA CIRCUIT ROAD
CH 0+000 - 4+941.092 Km

REV : MAY 2024
DRG NO : DM/RD/CS/11
CHAINAGE : 1+720-1+880
SHEET NO : 11

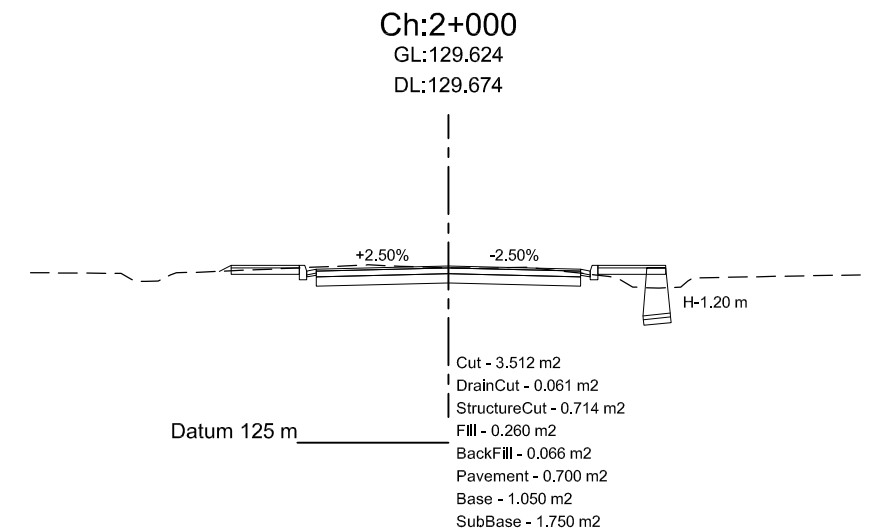
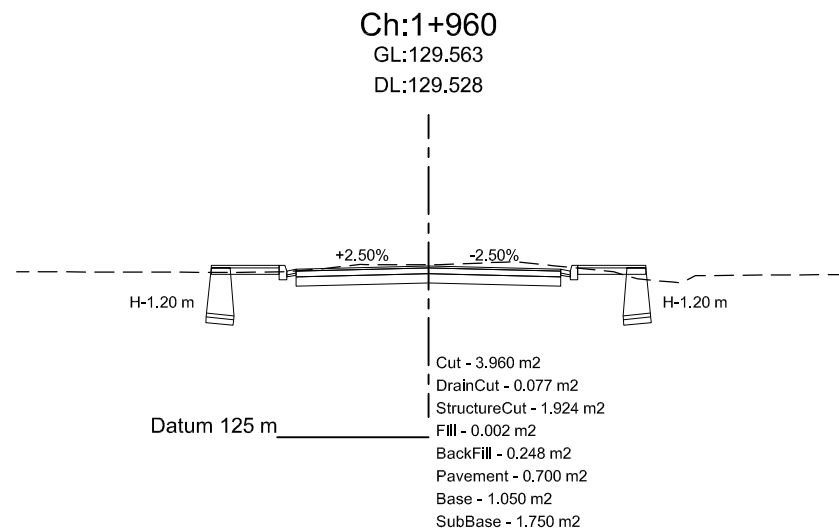
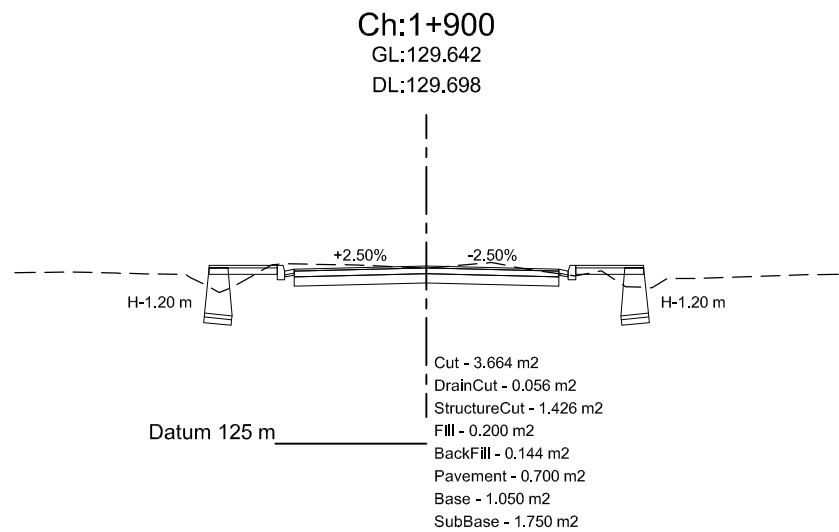
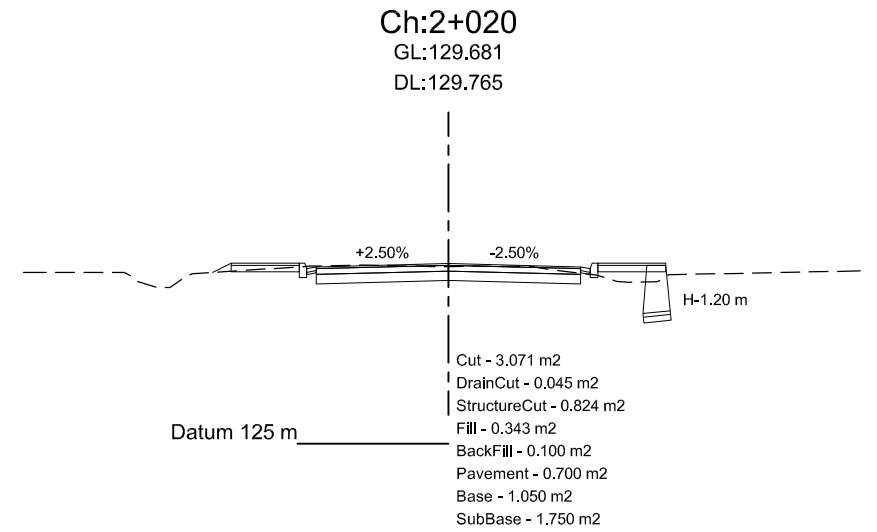
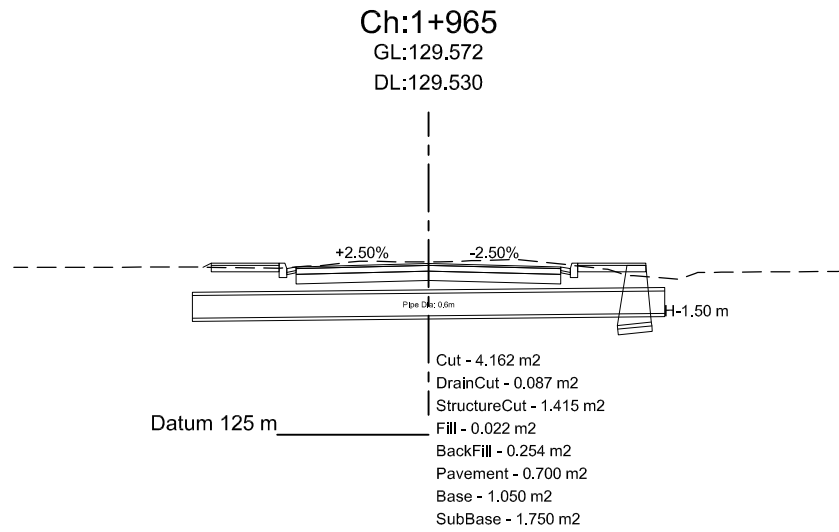
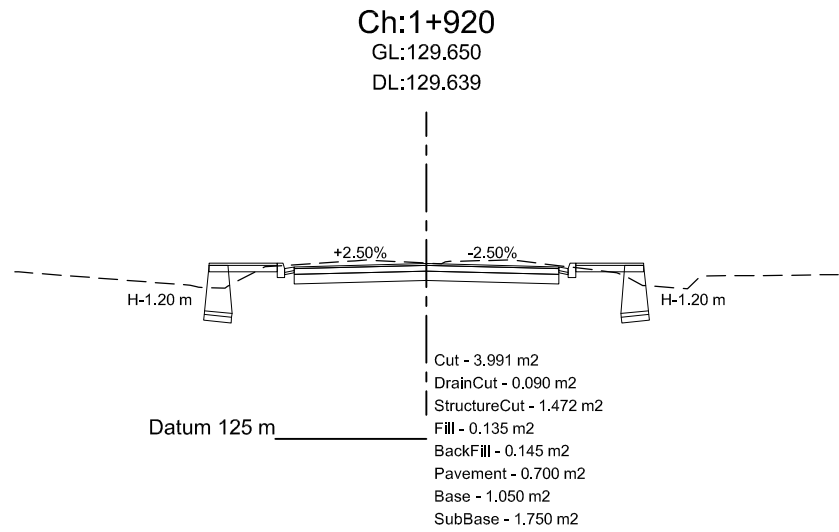
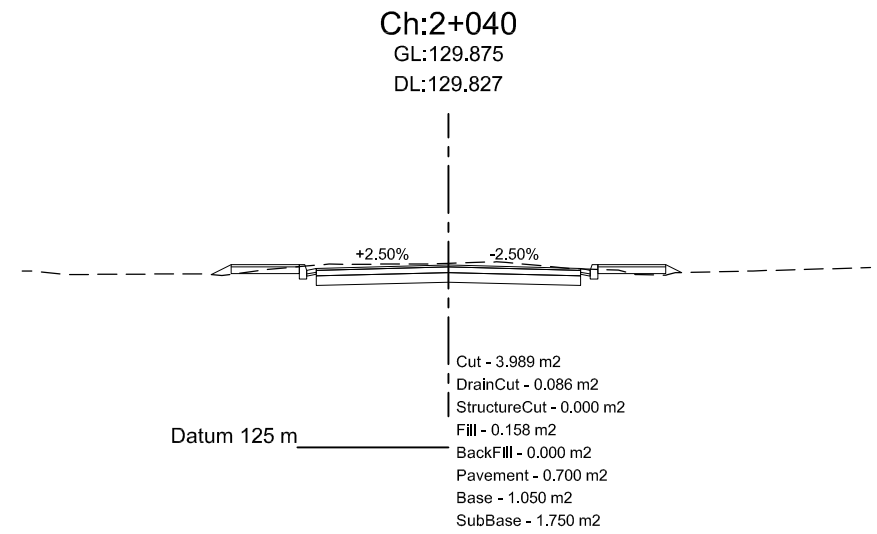
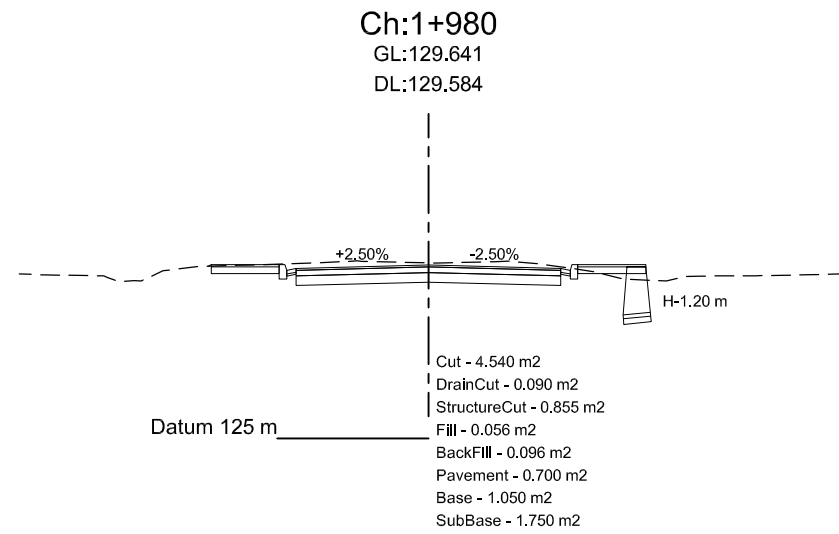
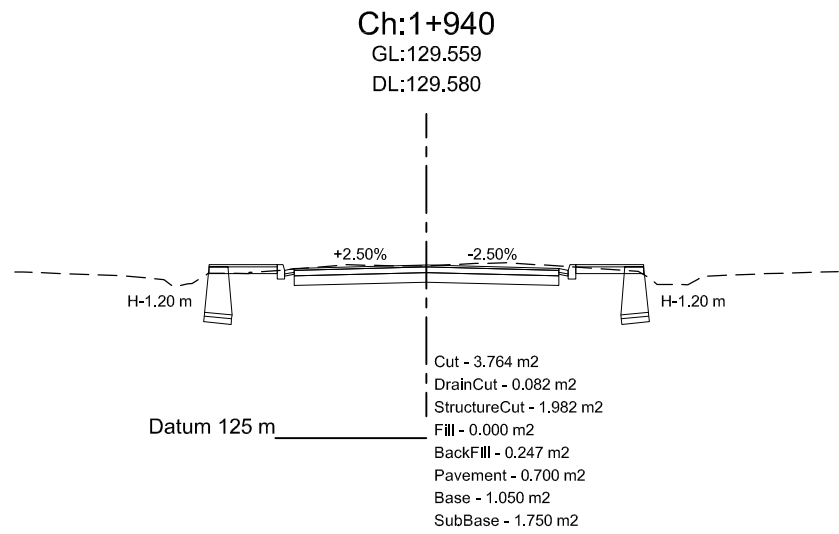

Department of Urban Development & Building
Construction (DUDBC)
Regional Urban Development Project (RUDP)
West Urban Corridor (WUC) Development Project
Babarmahal, Kathmandu, Nepal

Reviewed & Designed By :
DOHWA Engineering Co. Ltd.
in Association with
ERMIC (P.) Ltd., SILT Consultants (P.) Ltd., and
DIGICON (P.) Ltd.
Mid- Baneshwor, Kathmandu
Tel: 01- 4589393

Consultant
Team Leader : YOO CHANGMIN
Reviewed By : YAGYA BAHADUR MALLA
Designed By : MANJU MUNANKARMI

Client
Approved By :
Checked By :

Scale

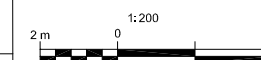

Cross-Section
BANCHAUKI-MAYADEVI PARK- MILDANDA
- BUDDHA CIRCUIT ROAD
CH 0+000 - 4+941.092 Km

REV : MAY 2024
DRG NO : DM/RD/CS/12
CHAINAGE : 1+900-2+040
SHEET NO : 12

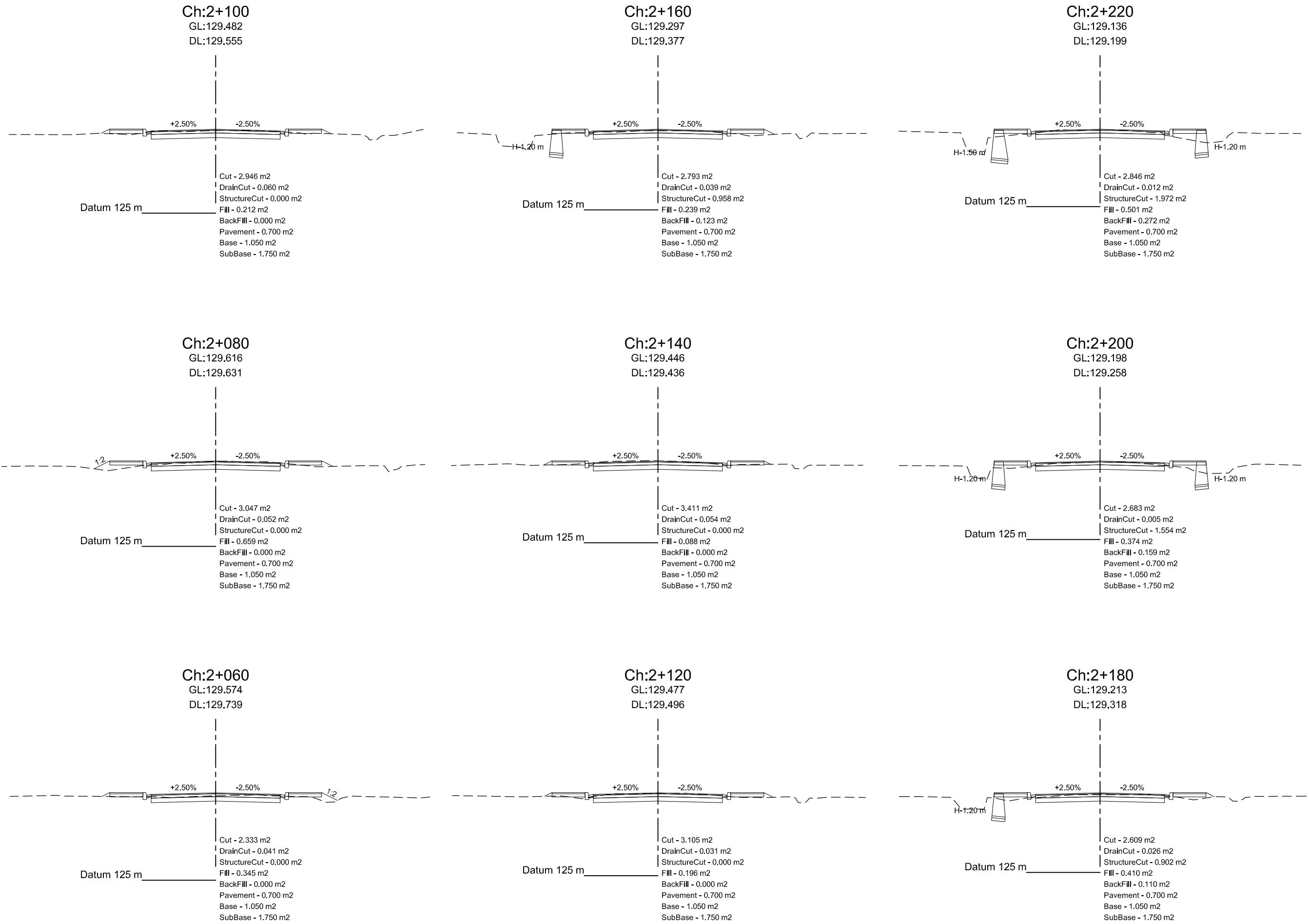

Department of Urban Development & Building
Construction (DUDBC)
Regional Urban Development Project (RUDP)
West Urban Corridor (WUC) Development Project
Babarmahal, Kathmandu, Nepal

Reviewed & Designed By :
DOHWA Engineering Co. Ltd.
in Association with
ERMIC (P.) Ltd., SILT Consultants (P.) Ltd., and
DIGICON (P.) Ltd.
Mid- Baneshwor, Kathmandu
Tel: 01- 4589393

Consultant
Team Leader : YOO CHANGMIN
Reviewed By : YAGYA BAHADUR MALLA
Designed By : MANJU MUNANKARMI

Client
Approved By :
Checked By :

Scale



Cross-Section
BANCHAUKI-MAYADEVI PARK- MILDANDA
- BUDDHA CIRCUIT ROAD
CH 0+000 - 4+941.092 Km

REV : MAY 2024
DRG NO : DM/RD/CS/13
CHAINAGE : 2+060-2+220
SHEET NO : 13

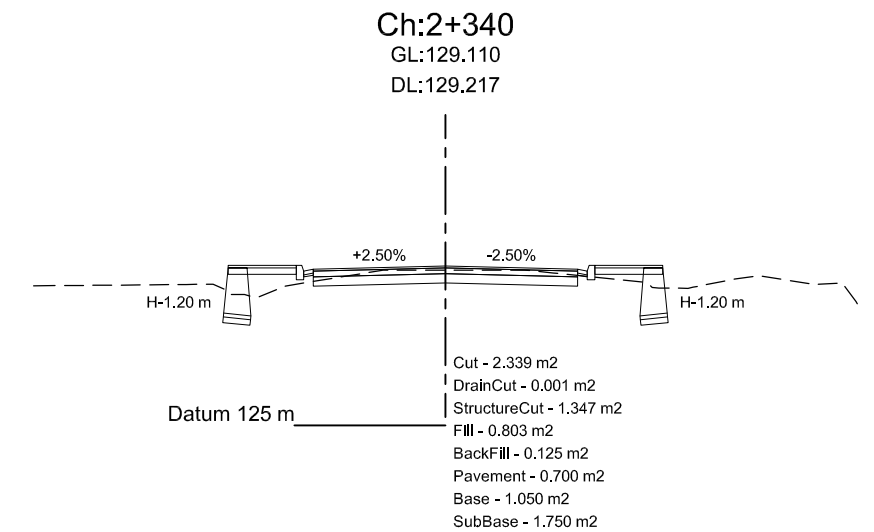
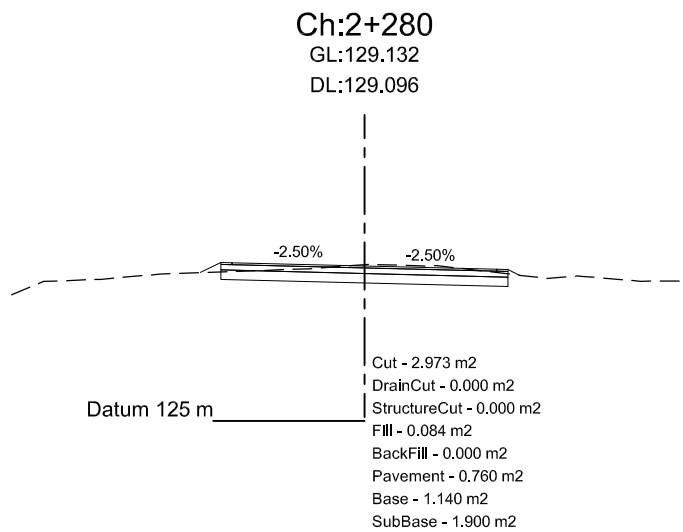
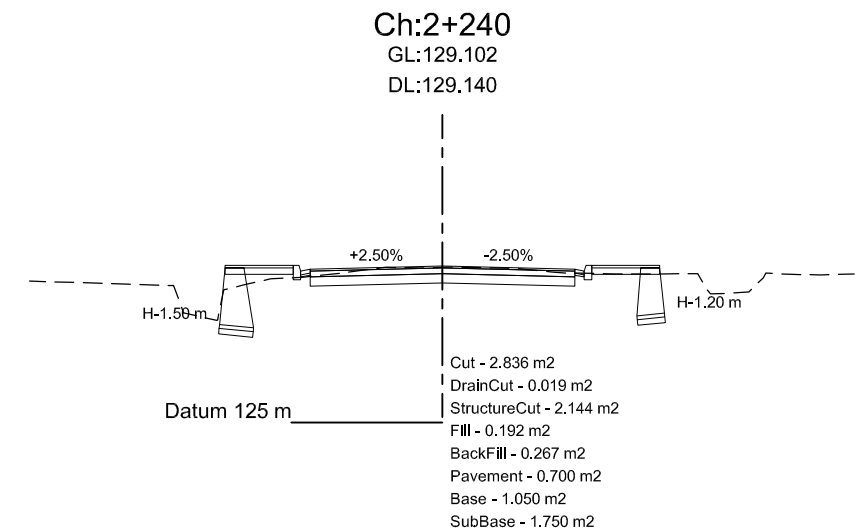
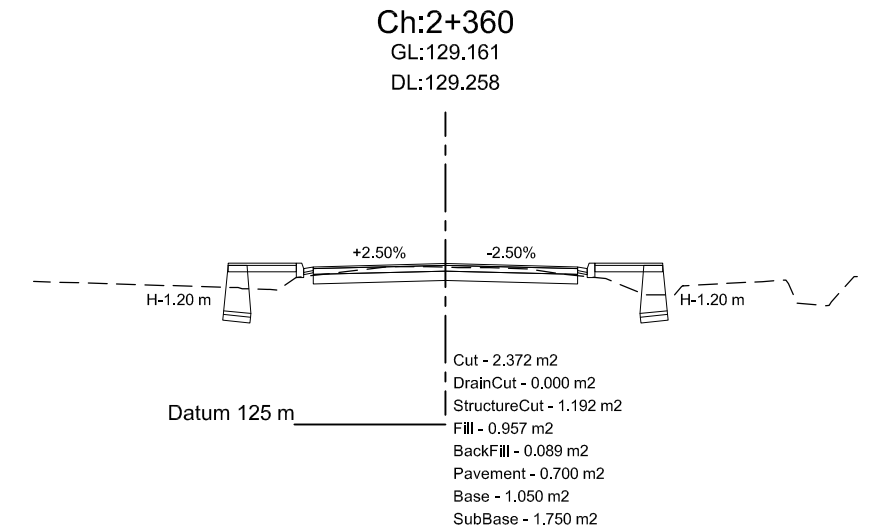
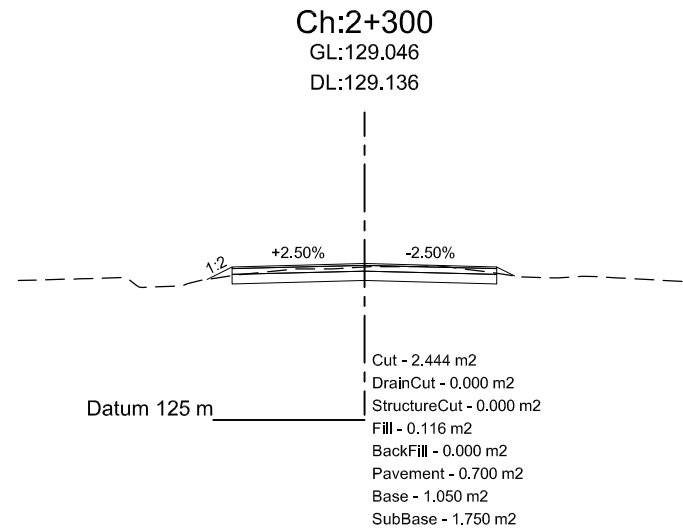
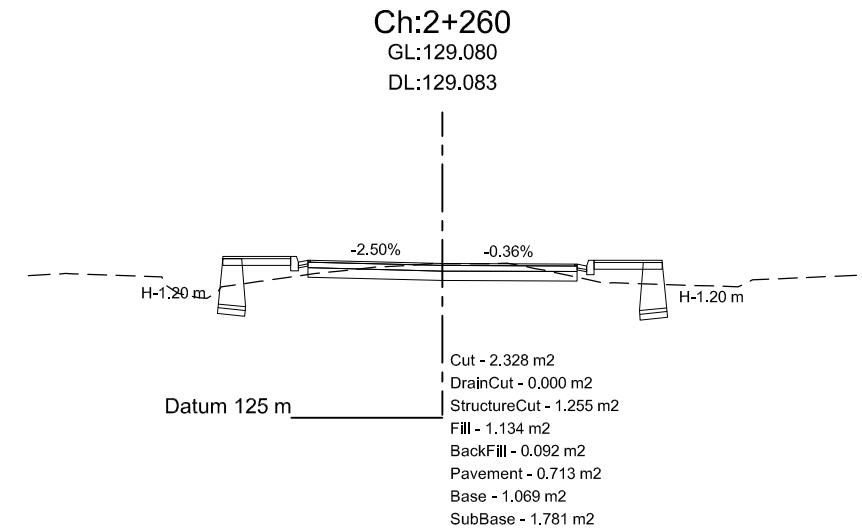
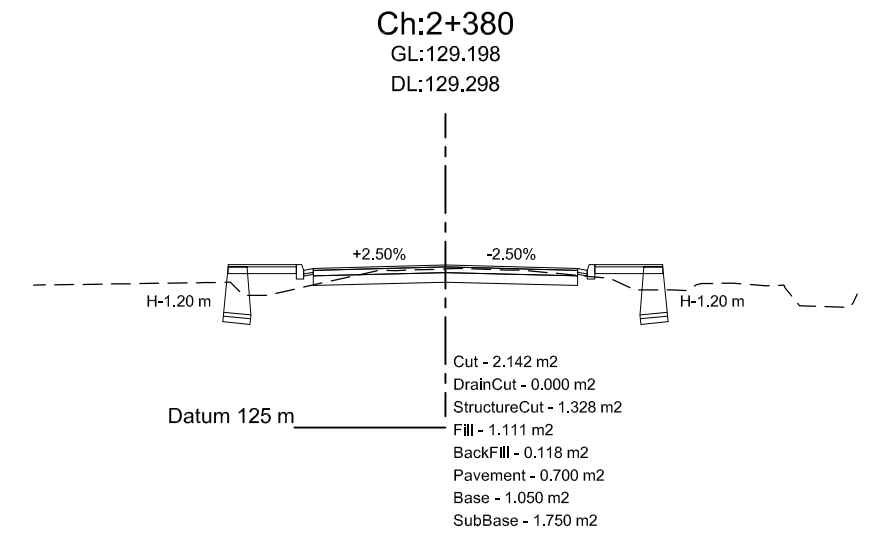
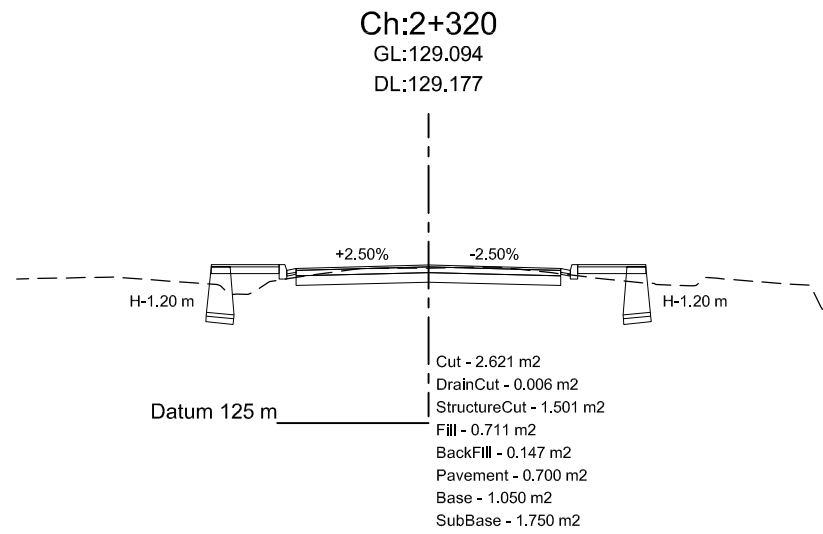
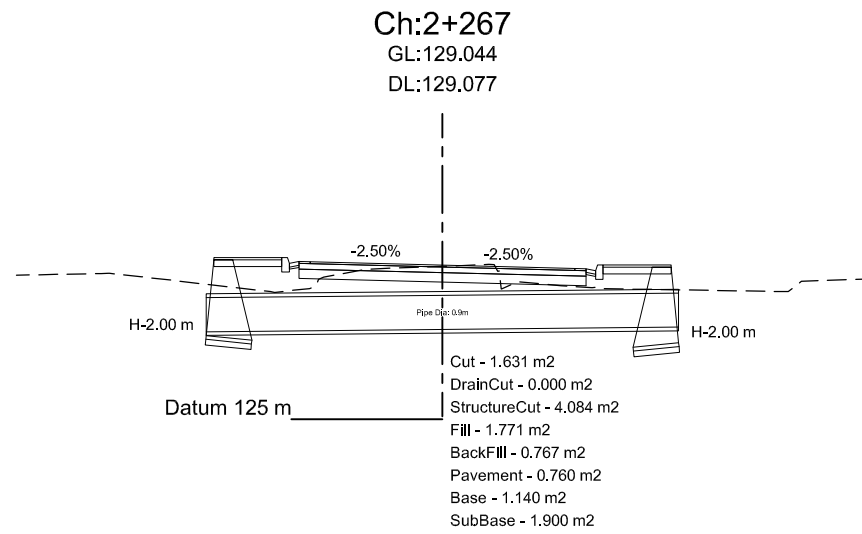

Department of Urban Development & Building Construction (DUDBC)
Regional Urban Development Project (RUDP)
West Urban Corridor (WUC) Development Project
Babarmahal, Kathmandu, Nepal

Reviewed & Designed By :
DOHWA Engineering Co. Ltd.
in Association with
ERMIC (P.) Ltd., SILT Consultants (P.) Ltd., and
DIGICON (P.) Ltd.
Mid- Baneshwor, Kathmandu
Tel: 01- 4589393

Consultant
Team Leader : YOO CHANGMIN
Reviewed By : YAGYA BAHADUR MALLA
Designed By : MANJU MUNANKARMI

Client
Approved By :
Checked By :

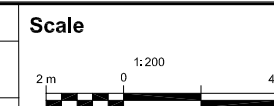

Cross-Section
BANCHAUKI-MAYADEVI PARK- MILDANDA
- BUDDHA CIRCUIT ROAD
CH 0+000 - 4+941.092 Km

REV : MAY 2024
DRG NO : DM/RD/CS/14
CHAINAGE : 2+240-2+380
SHEET NO : 14

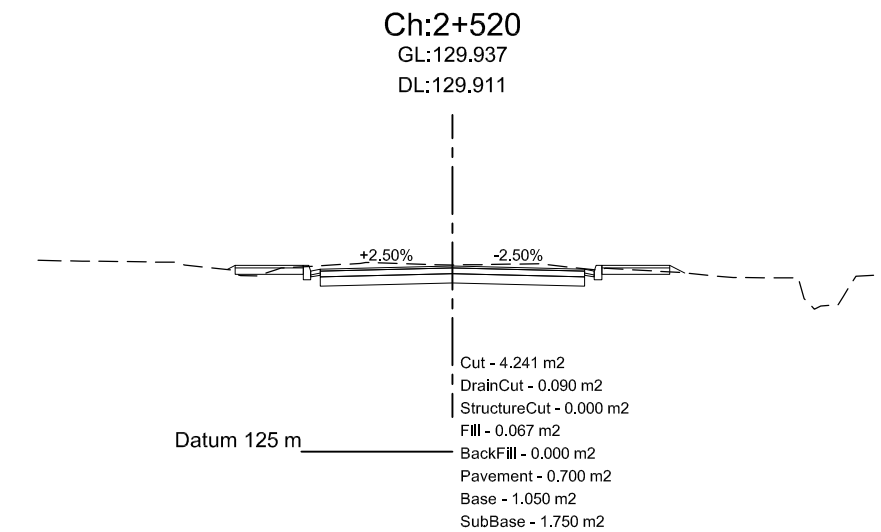
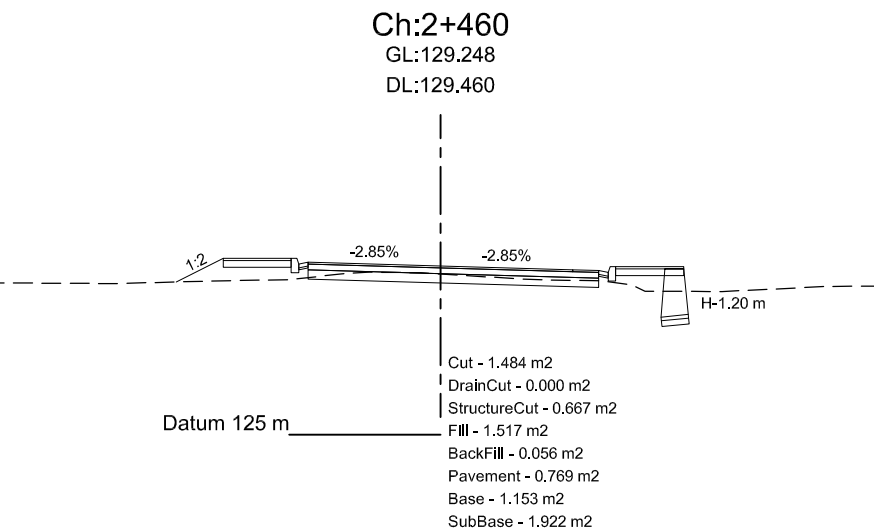
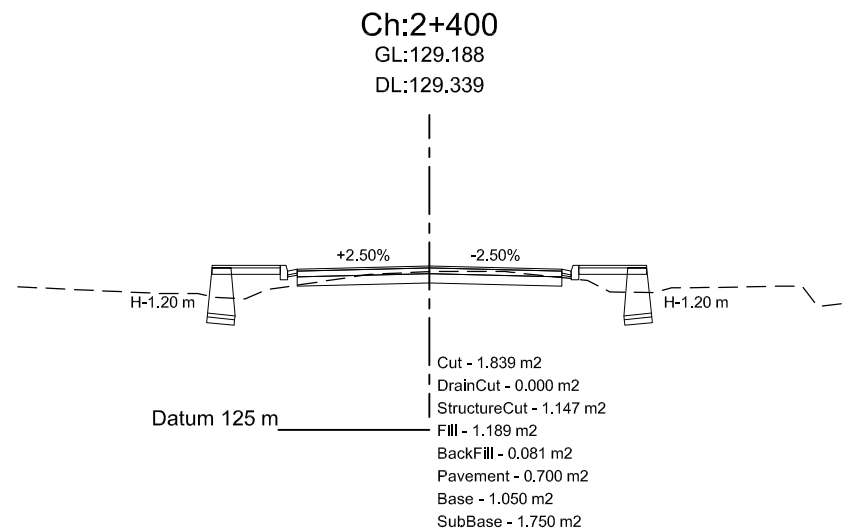
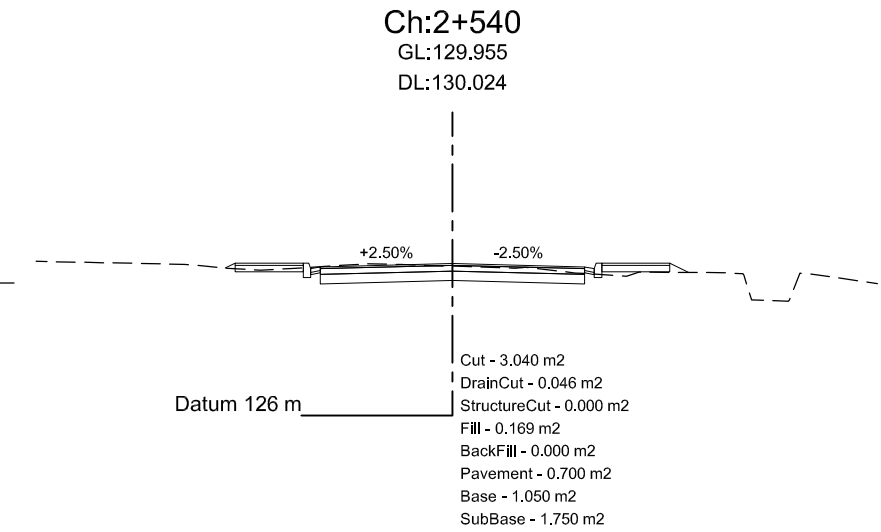
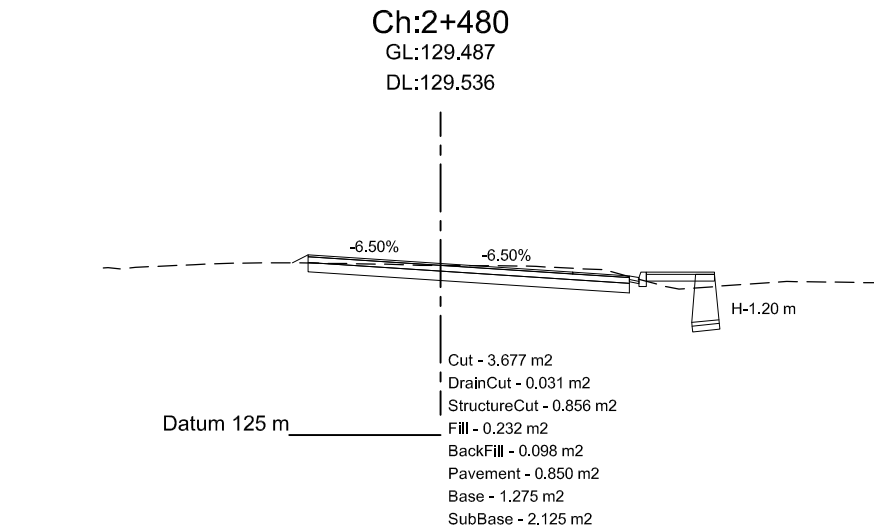
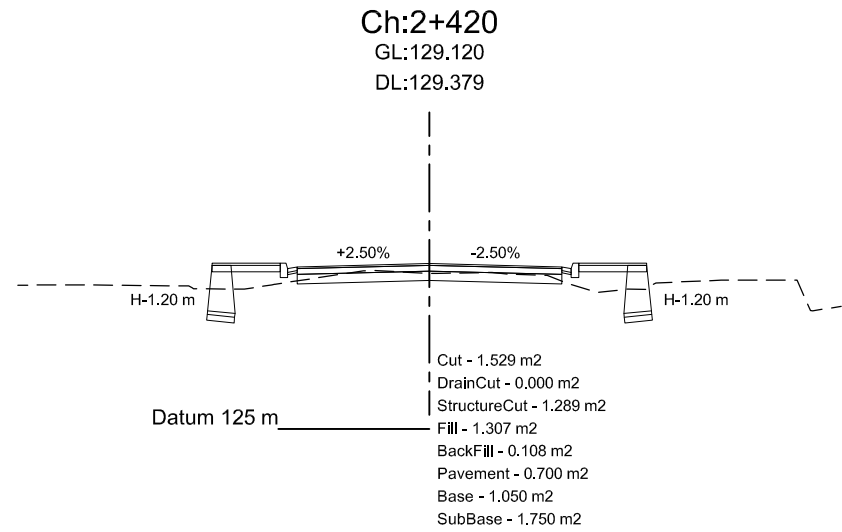
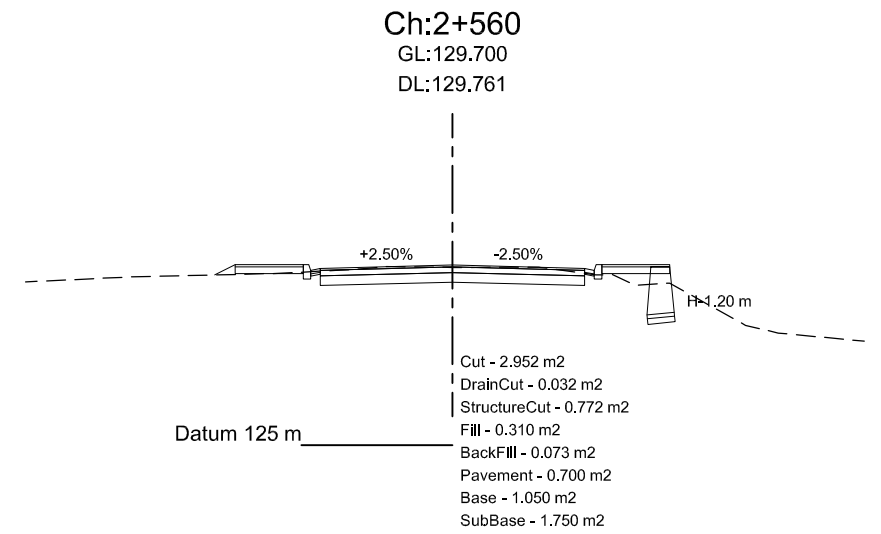
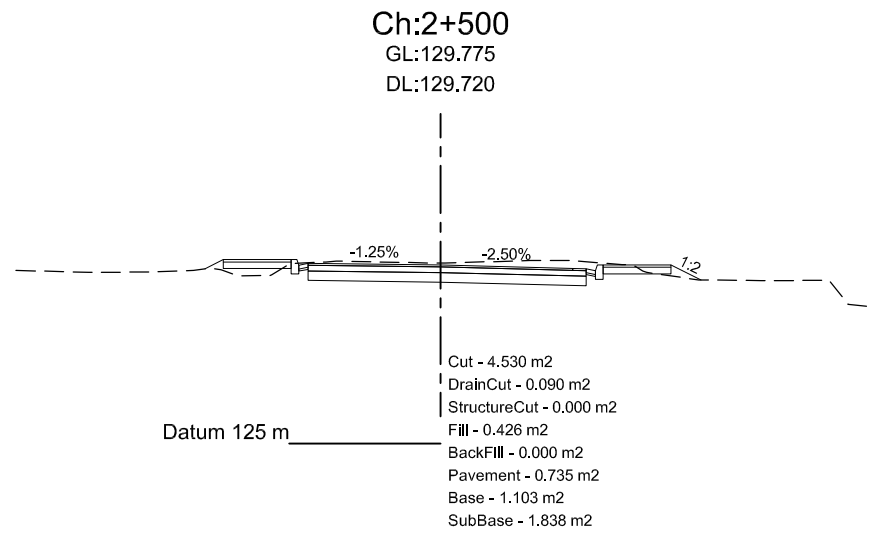
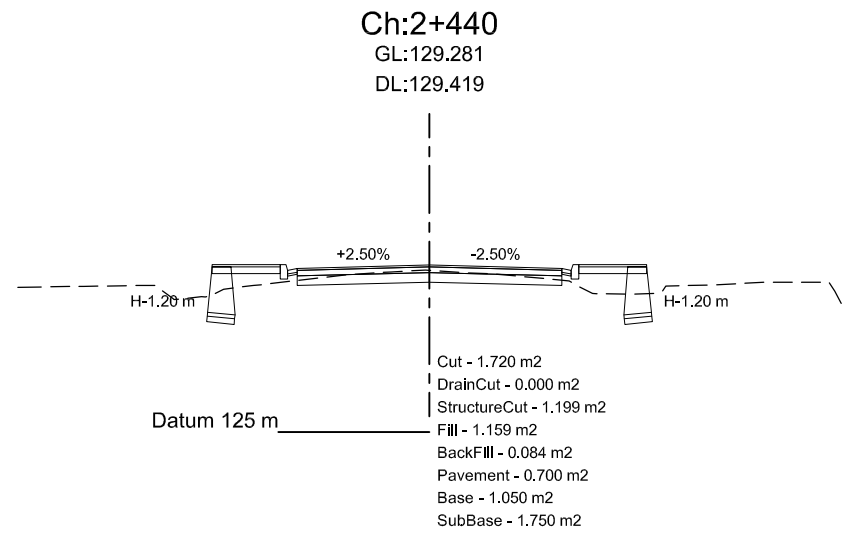

Department of Urban Development & Building
Construction (DUDBC)
Regional Urban Development Project (RUDP)
West Urban Corridor (WUC) Development Project
Babarmahal, Kathmandu, Nepal

Reviewed & Designed By :
DOHWA Engineering Co. Ltd.
in Association with
ERMIC (P.) Ltd., SILT Consultants (P.) Ltd., and
DIGICON (P.) Ltd.
Mid- Baneshwor, Kathmandu
Tel: 01-4589393

Consultant
Team Leader : YOO CHANGMIN
Reviewed By : YAGYA BAHADUR MALLA
Designed By : MANJU MUNANKARMI

Client
Approved By :
Checked By :

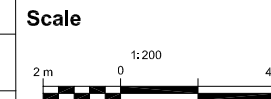

Cross-Section
BANCHAUKI-MAYADEVI PARK- MILDANDA
- BUDDHA CIRCUIT ROAD
CH 0+000 - 4+941.092 Km

REV : MAY 2024
DRG NO : DM/RD/CS/15
CHAINAGE : 2+400-2+560
SHEET NO : 15

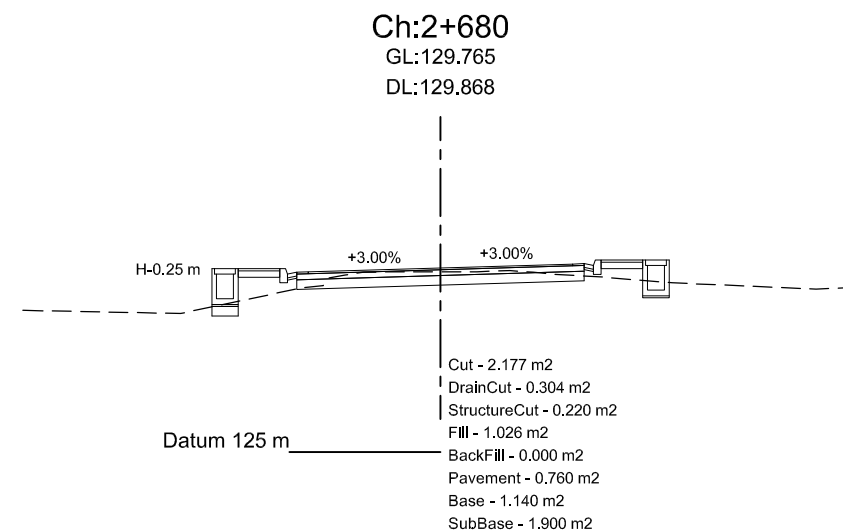
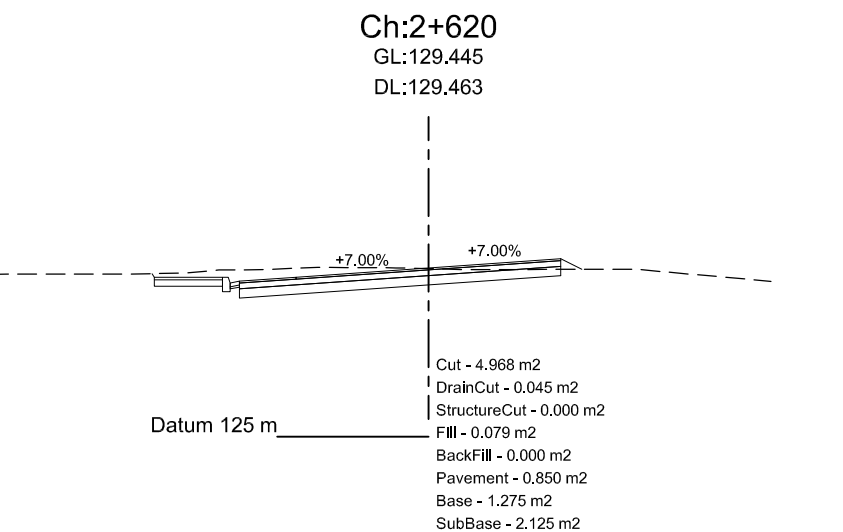
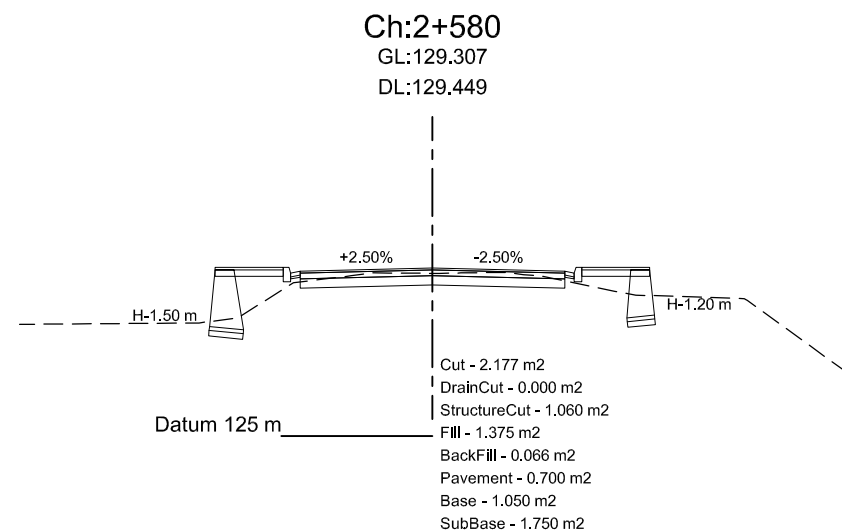
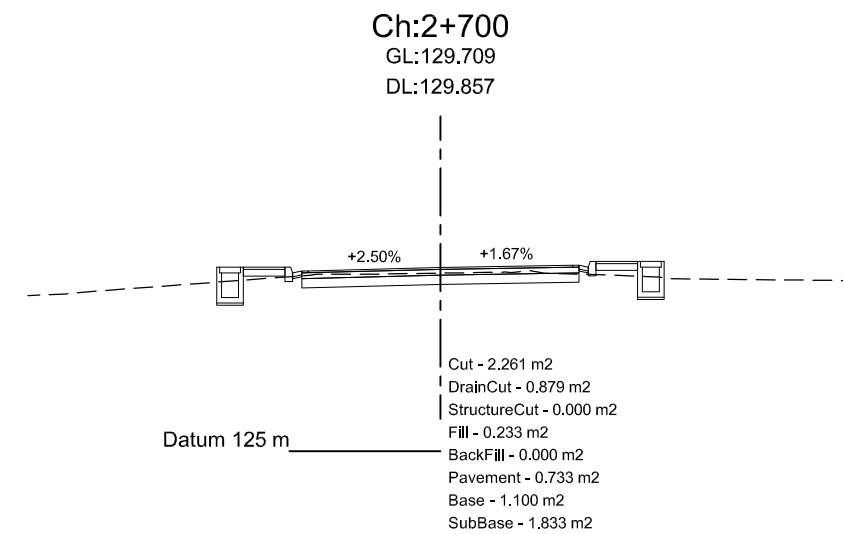
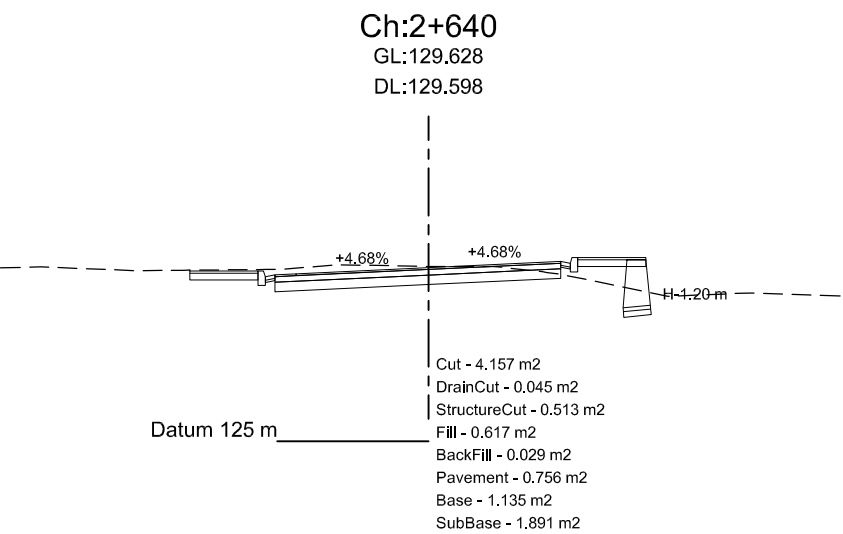
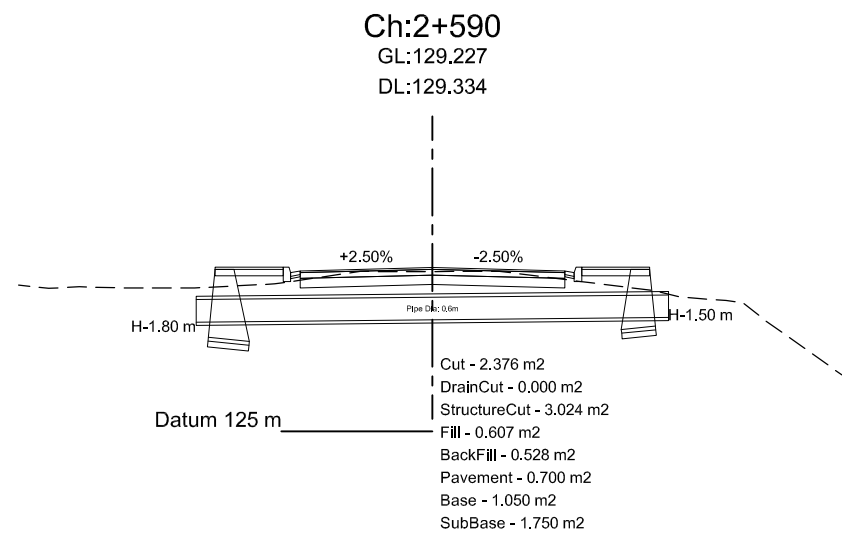
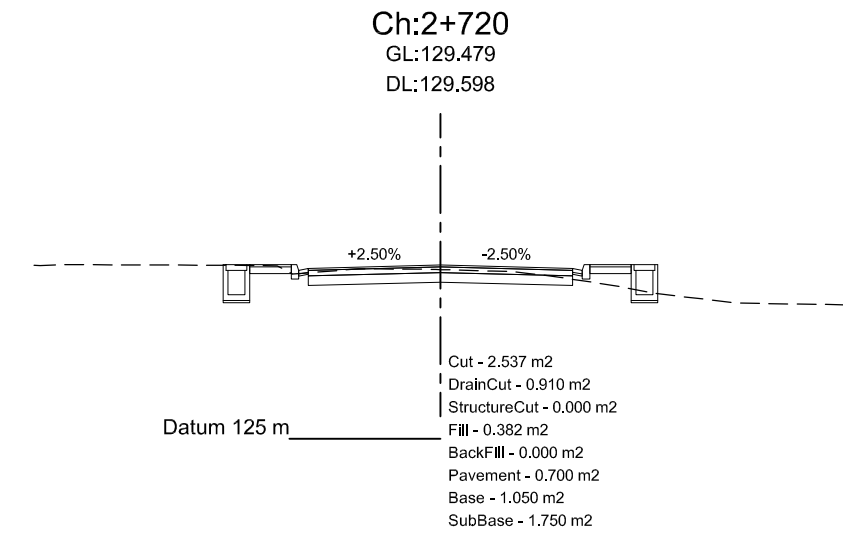
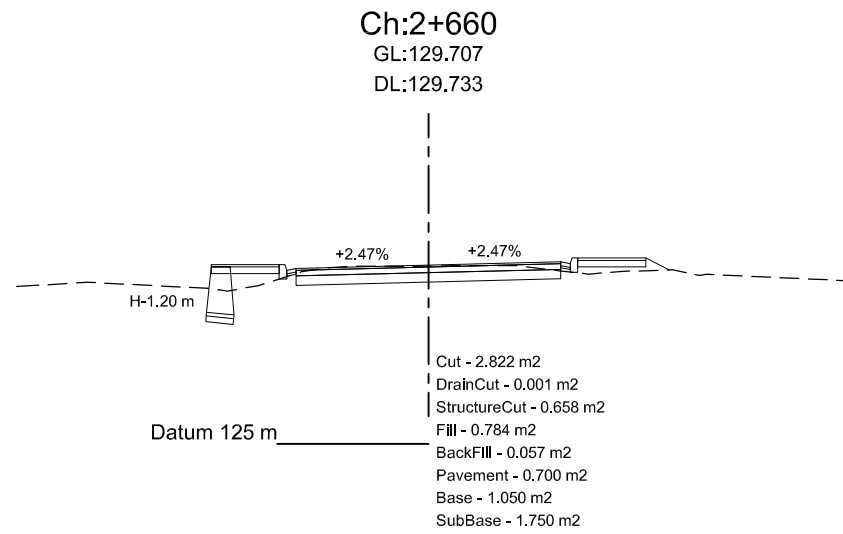
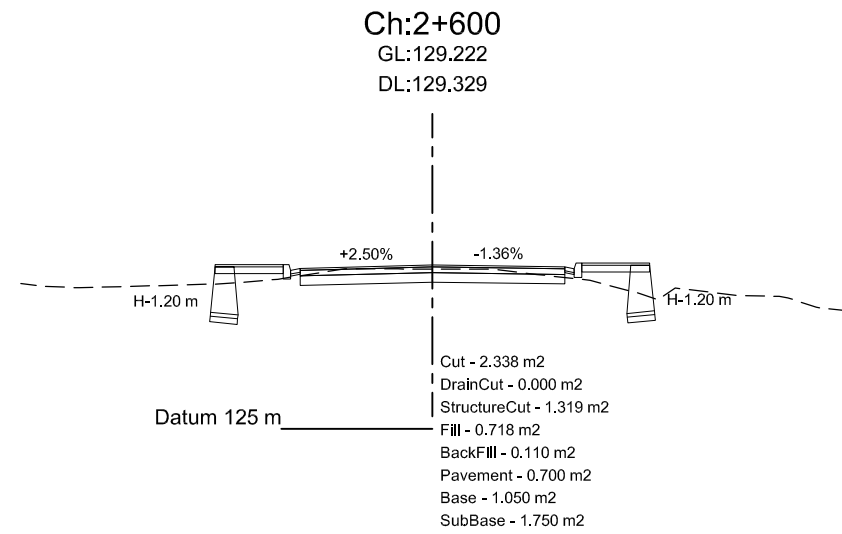

Department of Urban Development & Building Construction (DUDBC)
Regional Urban Development Project (RUDP)
West Urban Corridor (WUC) Development Project
Babarmahal, Kathmandu, Nepal

Reviewed & Designed By :
DOHWA Engineering Co. Ltd.
in Association with
ERMIC (P.) Ltd., SILT Consultants (P.) Ltd., and
DIGICON (P.) Ltd.
Mid- Baneshwor, Kathmandu
Tel: 01- 4589393

Consultant
Team Leader : YOO CHANGMIN
Reviewed By : YAGYA BAHADUR MALLA
Designed By : MANJU MUNANKARMI

Client
Approved By :
Checked By :

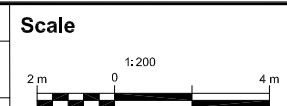

Cross-Section
BANCHAUKI-MAYADEVI PARK- MILDANDA
- BUDDHA CIRCUIT ROAD
CH 0+000 - 4+941.092 Km

REV : MAY 2024
DRG NO : DM/RD/CS/16
CHAINAGE : 2+580-2+720
SHEET NO : 16

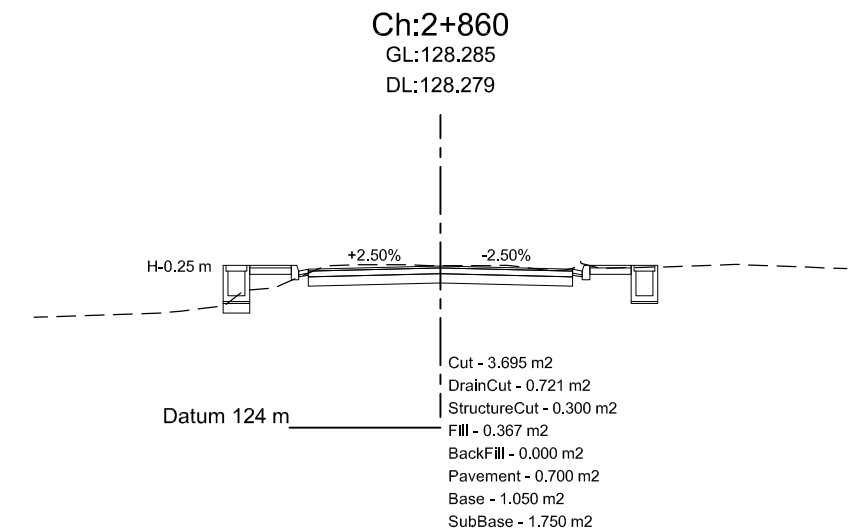
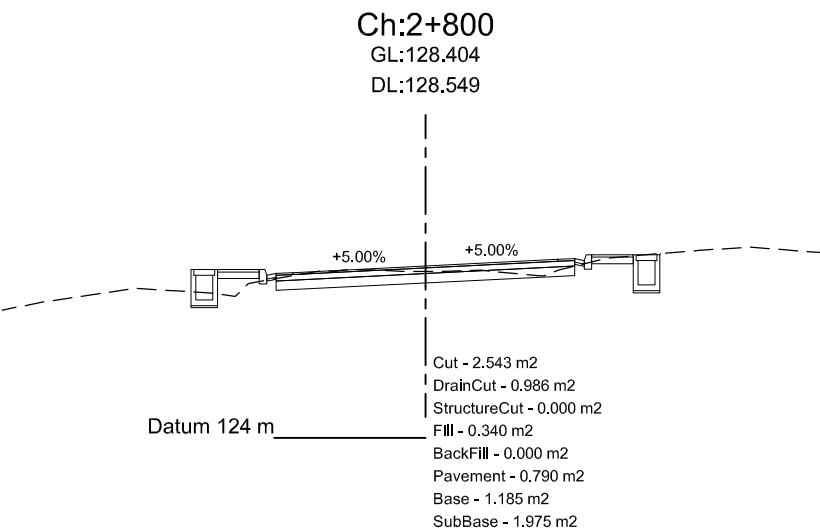
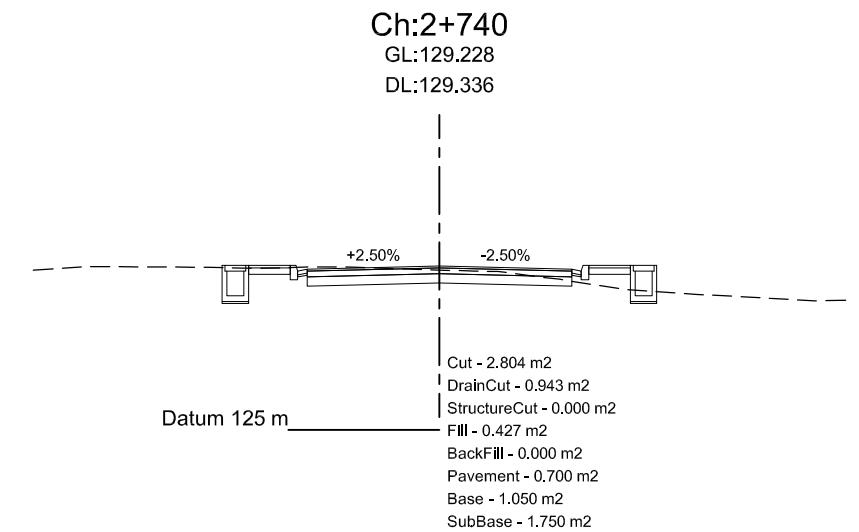
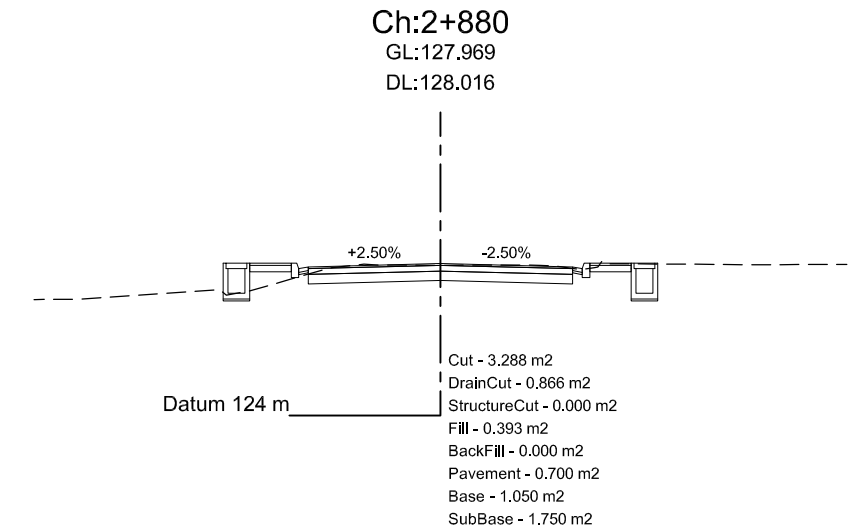
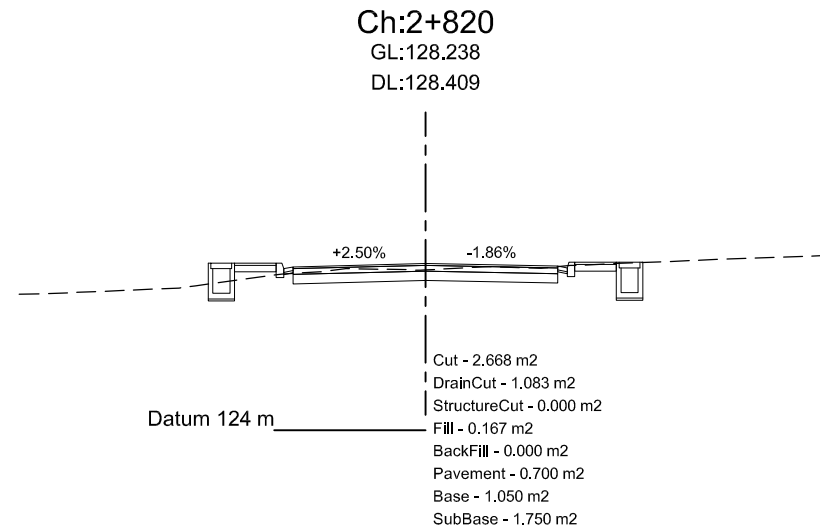
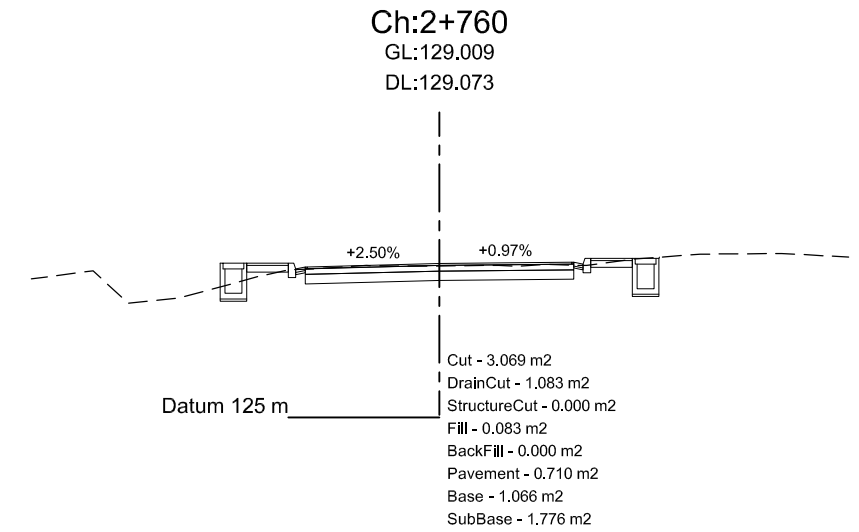
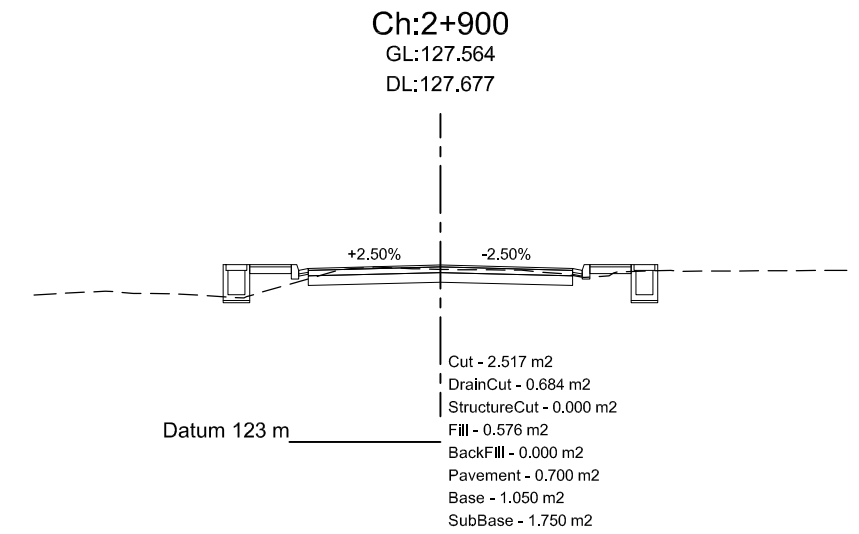
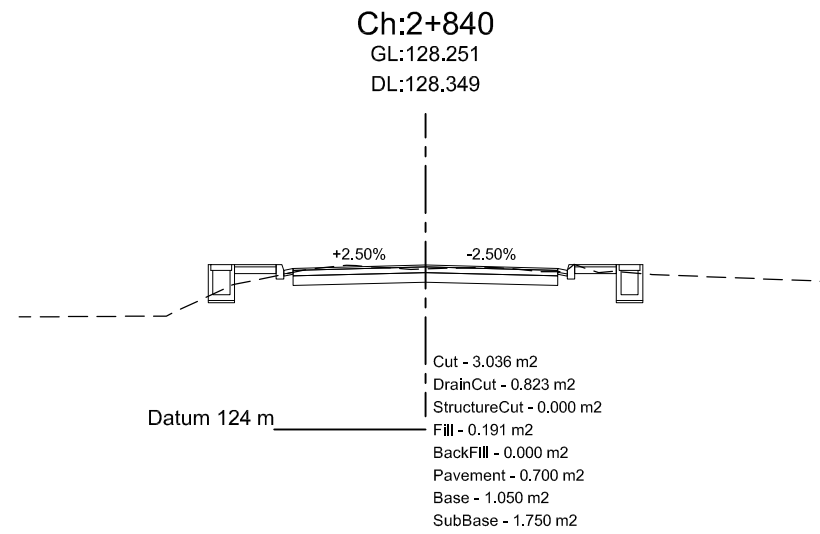
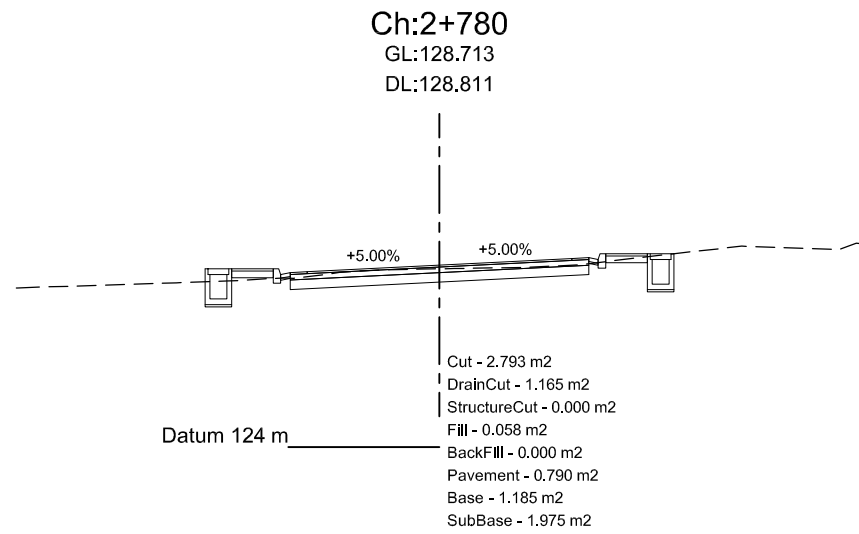

Department of Urban Development & Building
Construction (DUDBC)
Regional Urban Development Project (RUDP)
West Urban Corridor (WUC) Development Project
Babarmahal, Kathmandu, Nepal

Reviewed & Designed By :
DOHWA Engineering Co. Ltd.
in Association with
ERMIC (P.) Ltd., SILT Consultants (P.) Ltd., and
DIGICON (P.) Ltd.
Mid- Baneshwor, Kathmandu
Tel: 01- 4589393

Consultant
Team Leader : YOO CHANGMIN
Reviewed By : YAGYA BAHADUR MALLA
Designed By : MANJU MUNANKARMI

Client
Approved By :
Checked By :

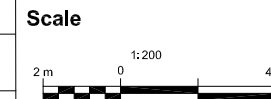

Cross-Section
BANCHAUKI-MAYADEVI PARK- MILDANDA
- BUDDHA CIRCUIT ROAD
CH 0+000 - 4+941.092 Km

REV : MAY 2024
DRG NO : DM/RD/CS/17
CHAINAGE : 2+740-2+900
SHEET NO : 17

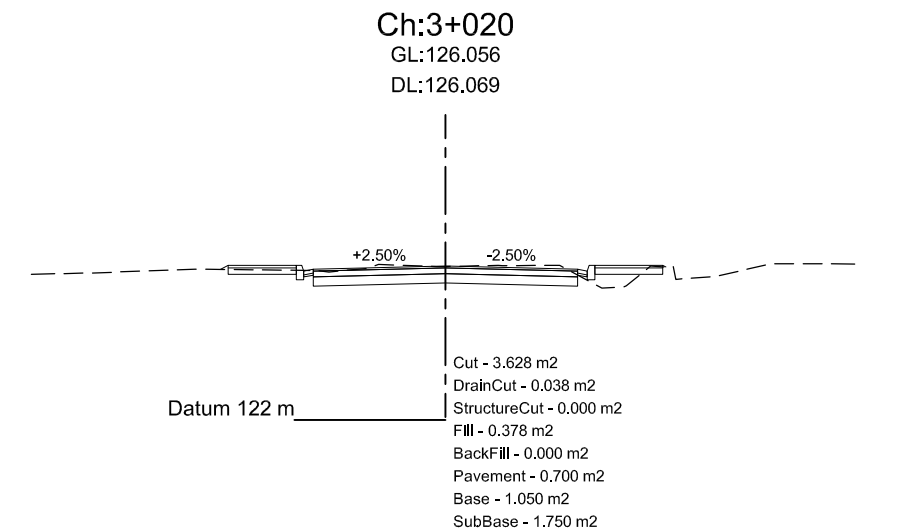
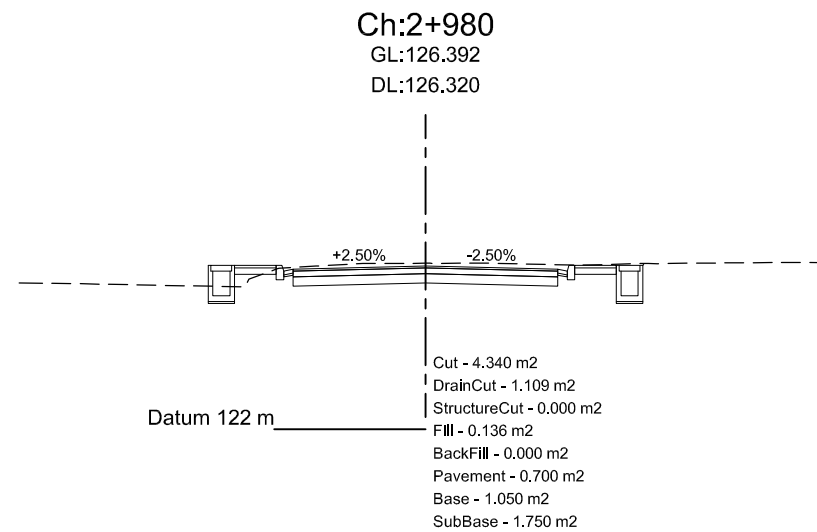
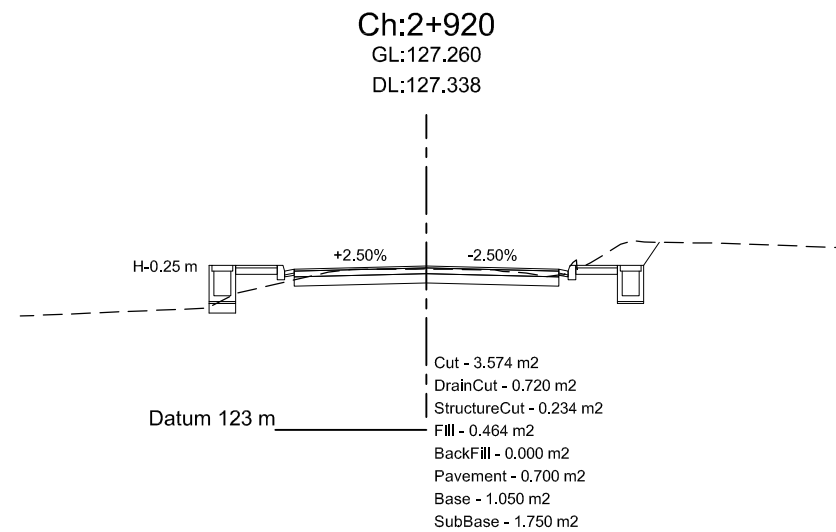
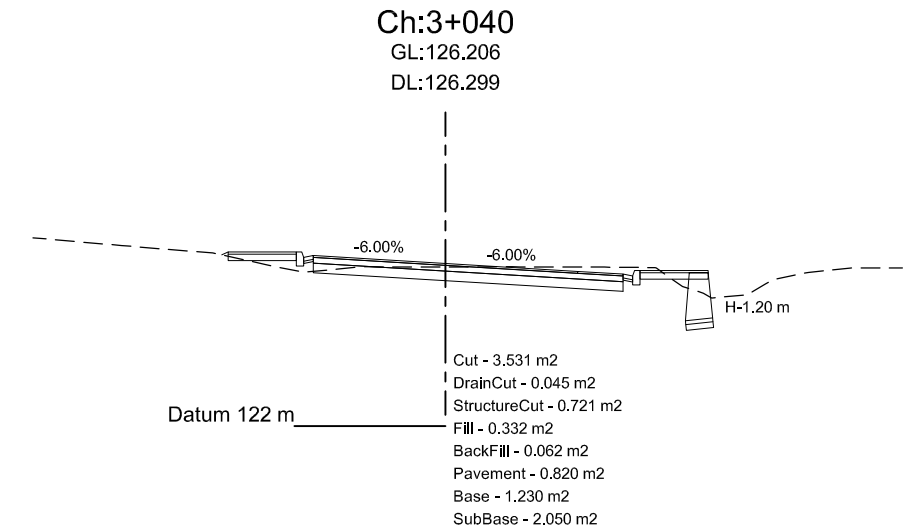
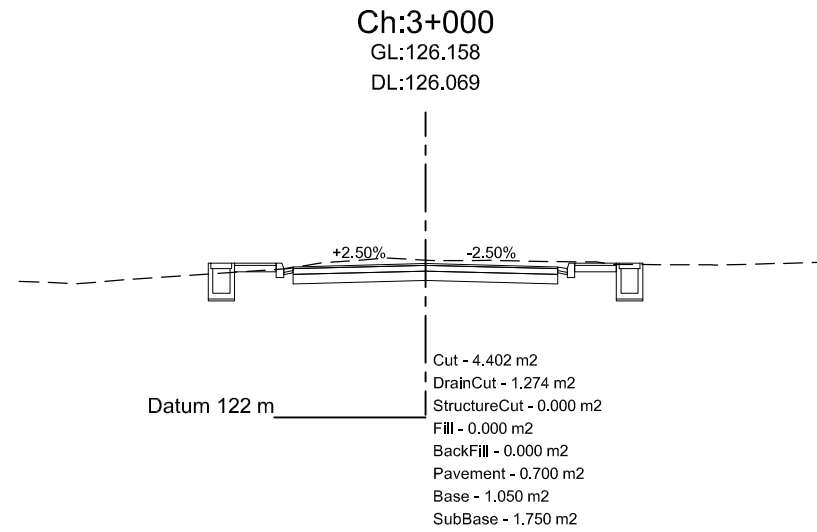
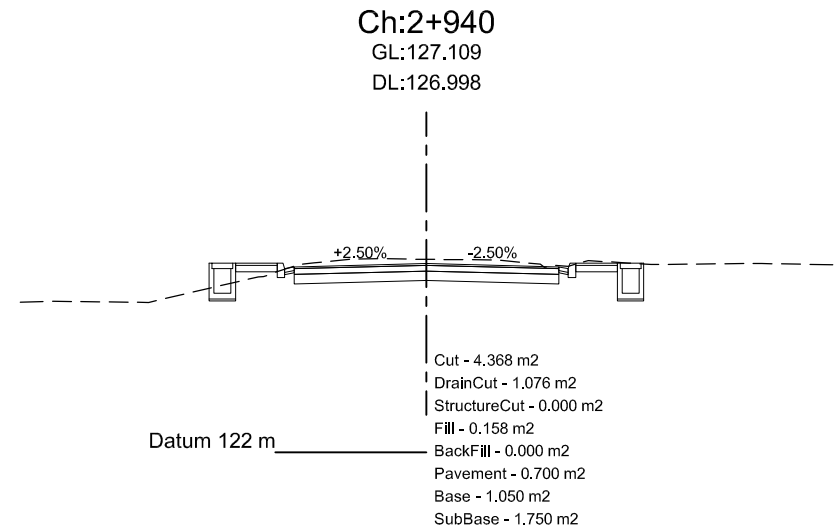
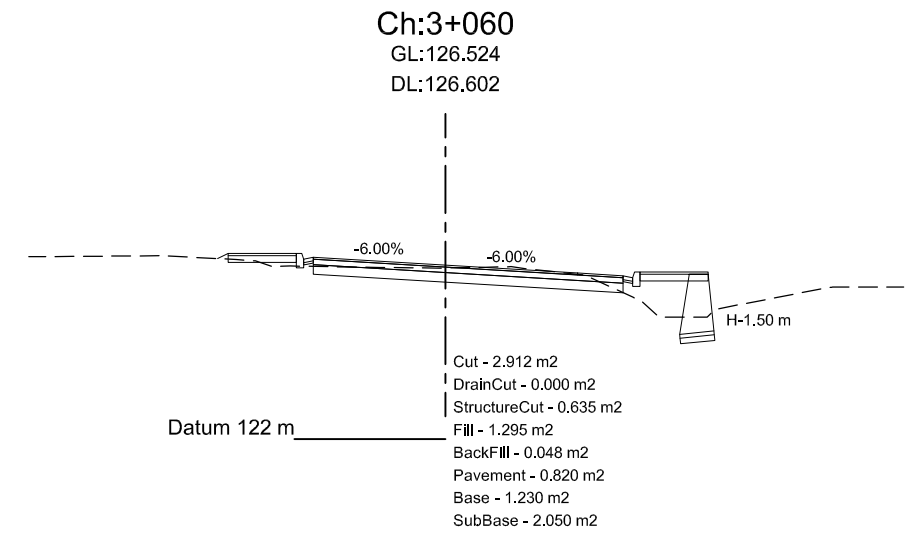
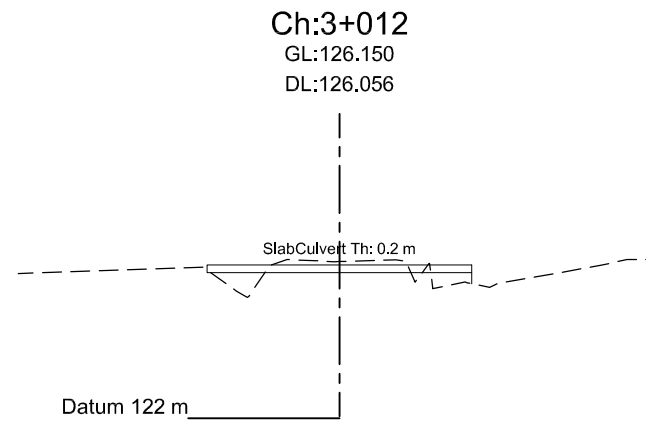
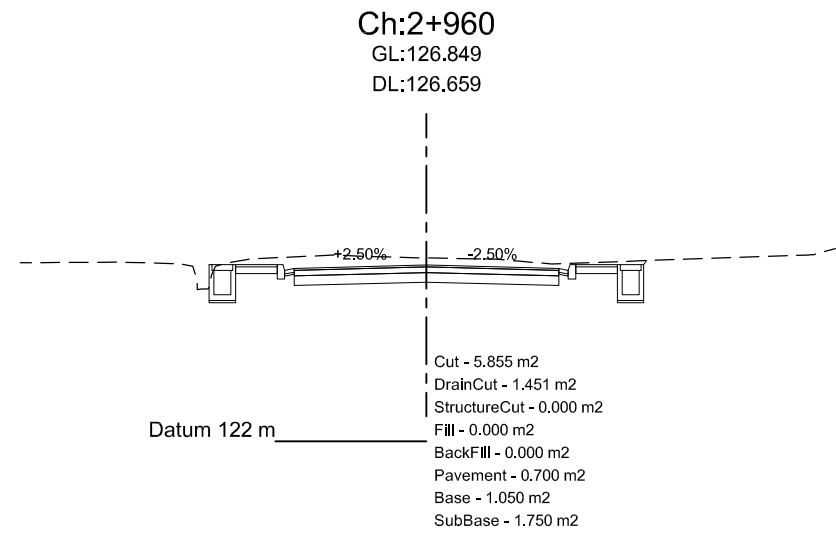

Department of Urban Development & Building Construction (DUDBC)
Regional Urban Development Project (RUDP)
West Urban Corridor (WUC) Development Project
Babarmahal, Kathmandu, Nepal

Reviewed & Designed By :
DOHWA Engineering Co. Ltd.
in Association with
ERMIC (P.) Ltd., SILT Consultants (P.) Ltd., and
DIGICON (P.) Ltd.
Mid-Baneshwor, Kathmandu
Tel: 01-4589393

Consultant
Team Leader : YOO CHANGMIN
Reviewed By : YAGYA BAHADUR MALLA
Designed By : MANJU MUNANKARMI

Client
Approved By :
Checked By :

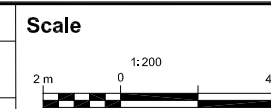

Cross-Section
BANCHAUKI-MAYADEVI PARK- MILDANDA
- BUDDHA CIRCUIT ROAD
CH 0+000 - 4+941.092 Km

REV : MAY 2024
DRG NO : DM/RD/CS/18
CHAINAGE : 2+920-3+060
SHEET NO : 18

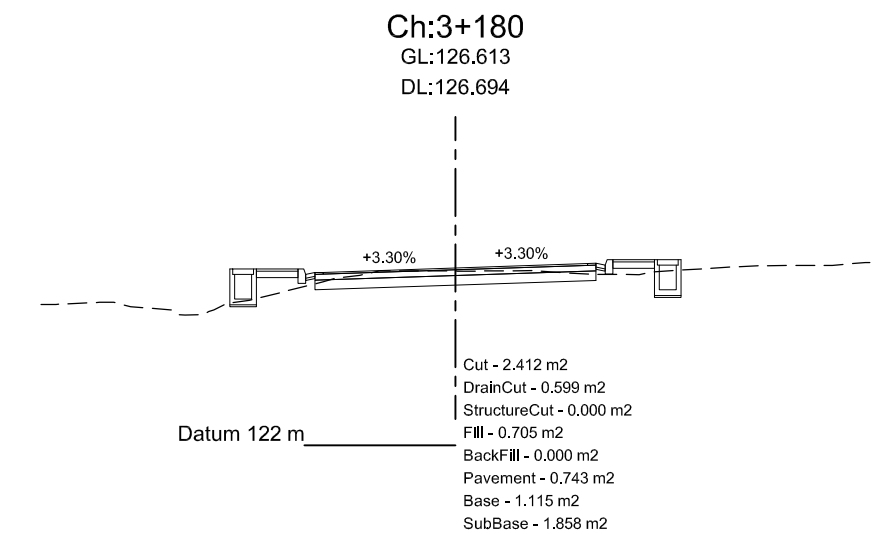
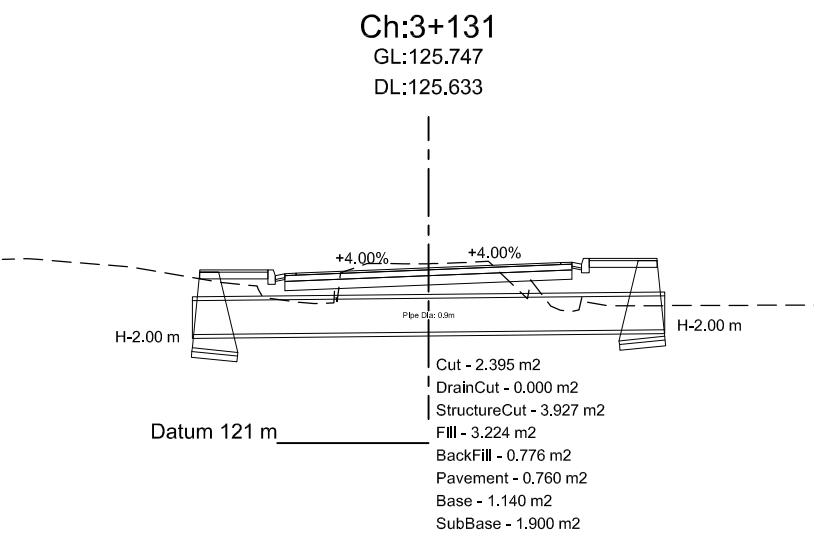
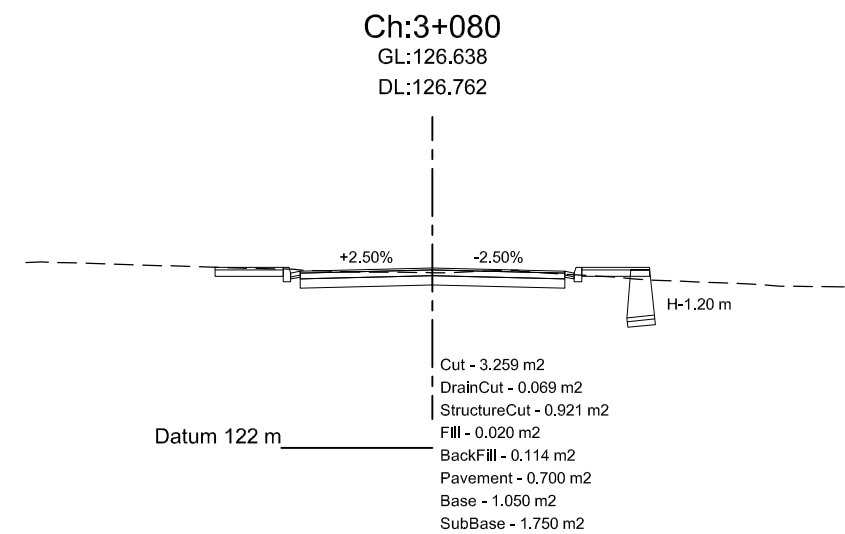
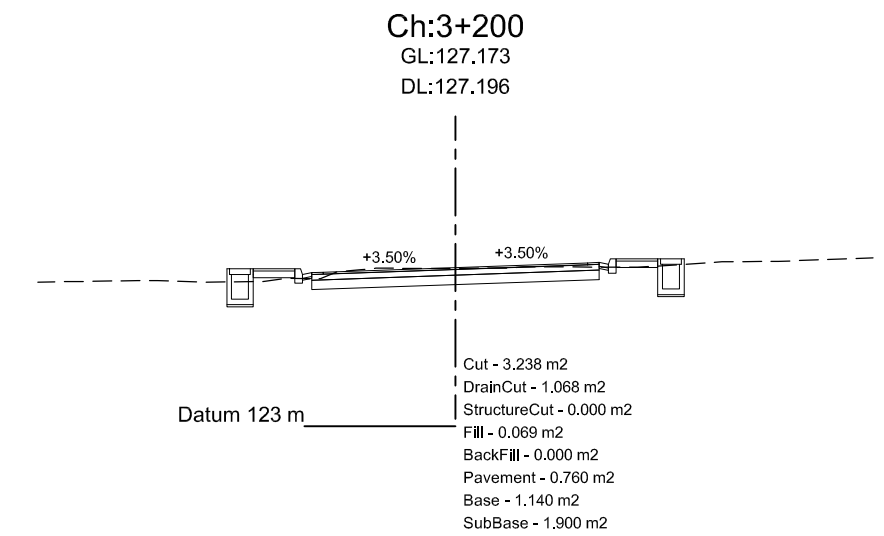
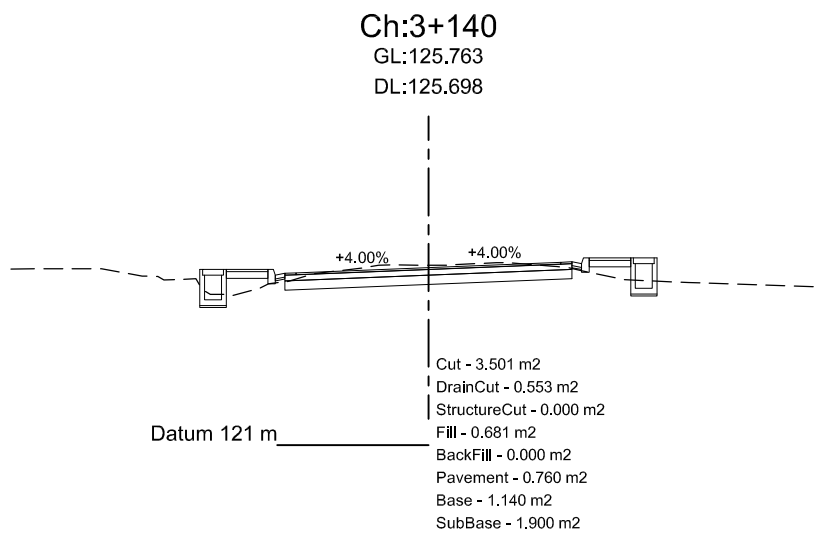
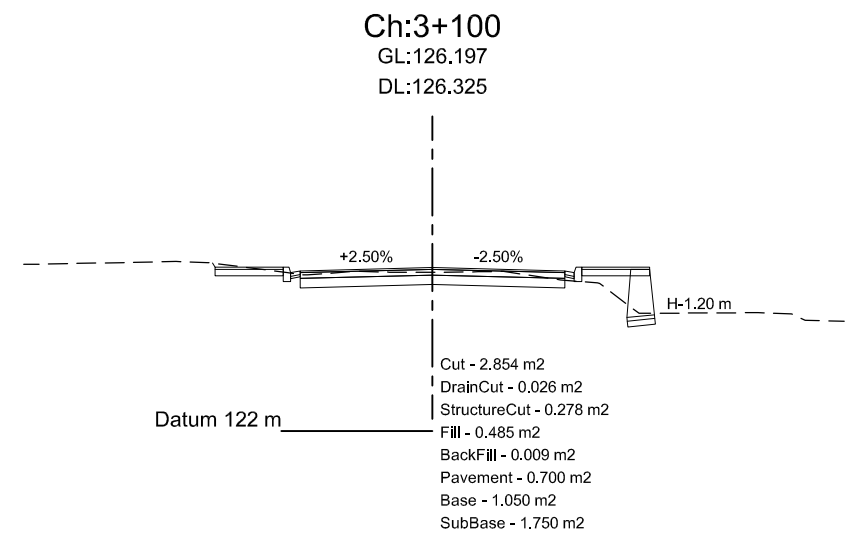
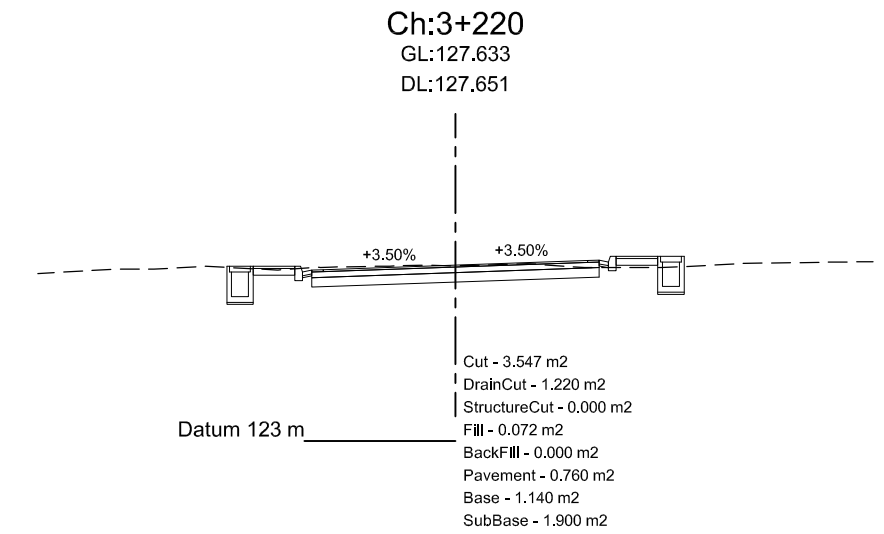
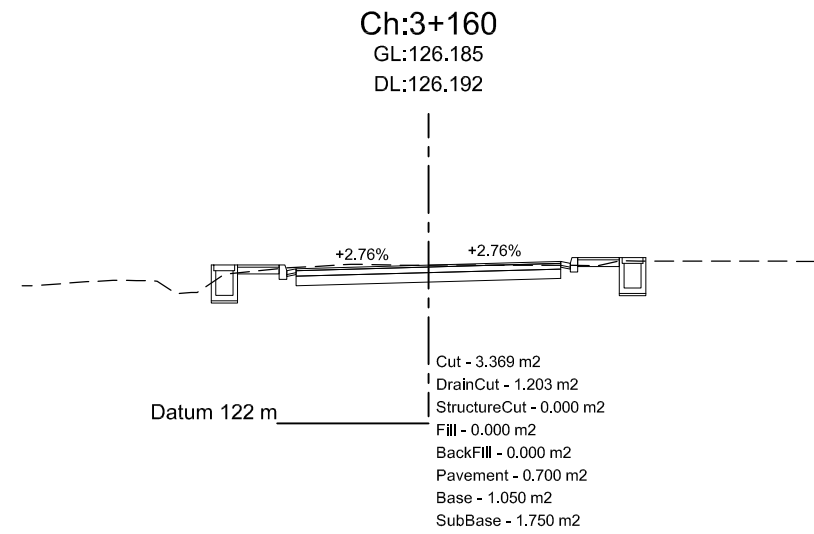
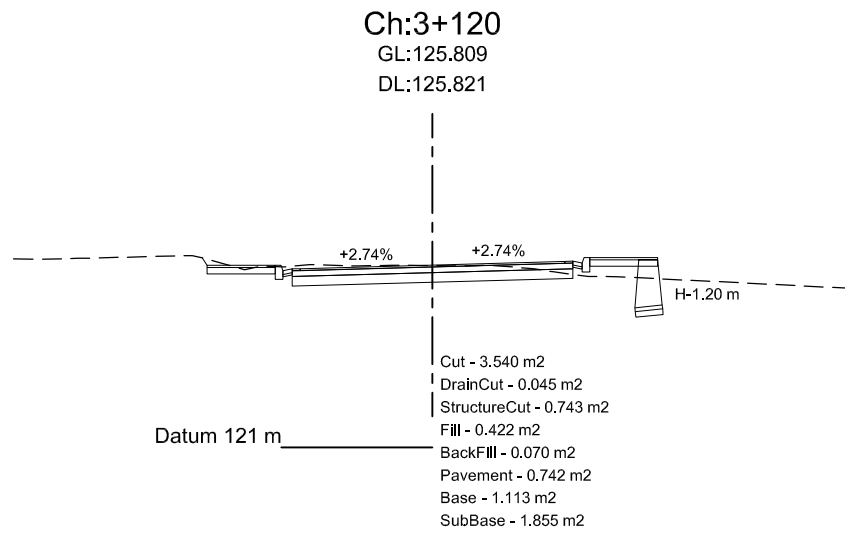

Department of Urban Development & Building Construction (DUDBC)
Regional Urban Development Project (RUDP)
West Urban Corridor (WUC) Development Project
Babarmahal, Kathmandu, Nepal

Reviewed & Designed By :
DOHWA Engineering Co. Ltd.
in Association with
ERMIC (P.) Ltd., SILT Consultants (P.) Ltd., and
DIGICON (P.) Ltd.
Mid-Baneshwor, Kathmandu
Tel: 01-4589393

Consultant
Team Leader : YOO CHANGMIN
Reviewed By : YAGYA BAHADUR MALLA
Designed By : MANJU MUNANKARMI

Client
Approved By :
Checked By :

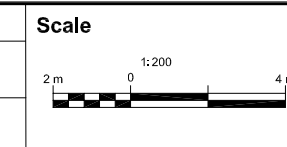

Cross-Section
BANCHAUKI-MAYADEVI PARK- MILDANDA
- BUDDHA CIRCUIT ROAD
CH 0+000 - 4+941.092 Km

REV : MAY 2024
DRG NO : DM/RD/CS/19
CHAINAGE : 3+080-3+220
SHEET NO : 19

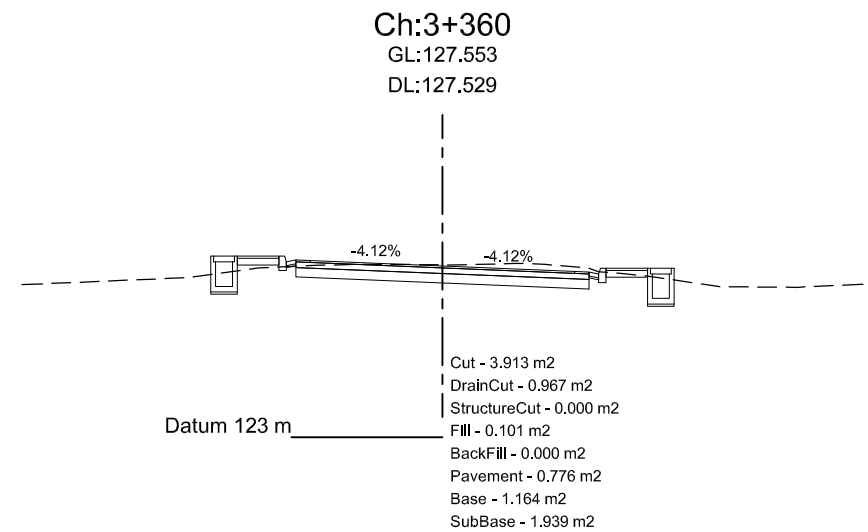
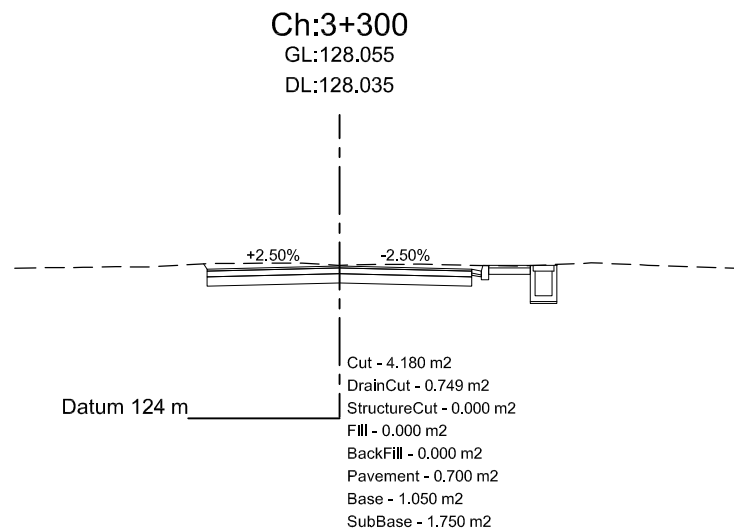
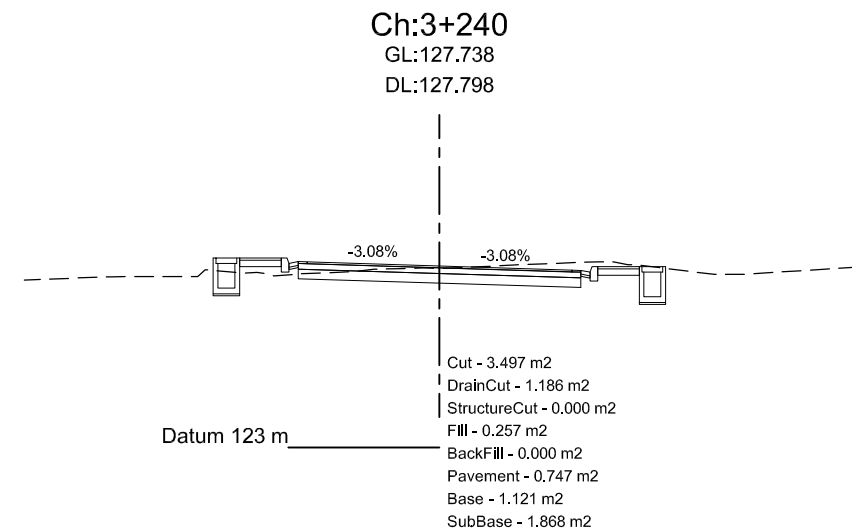
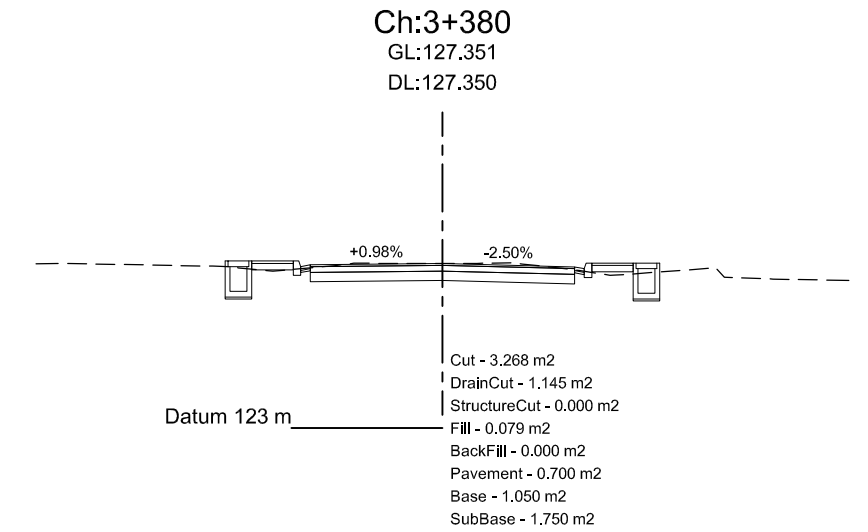
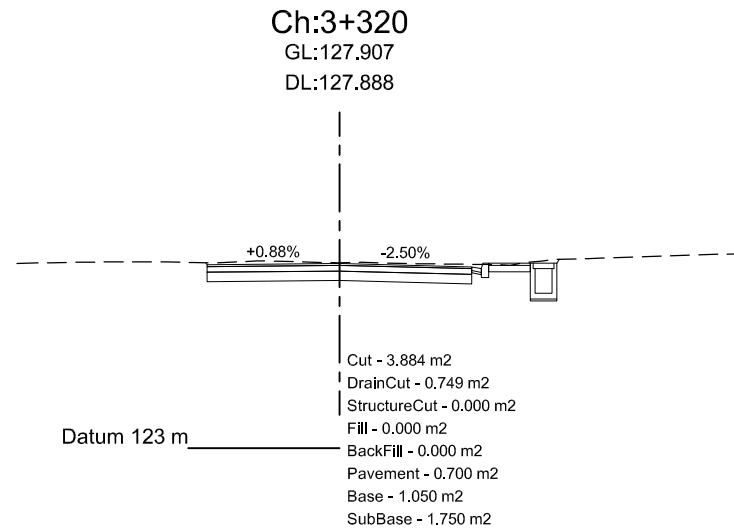
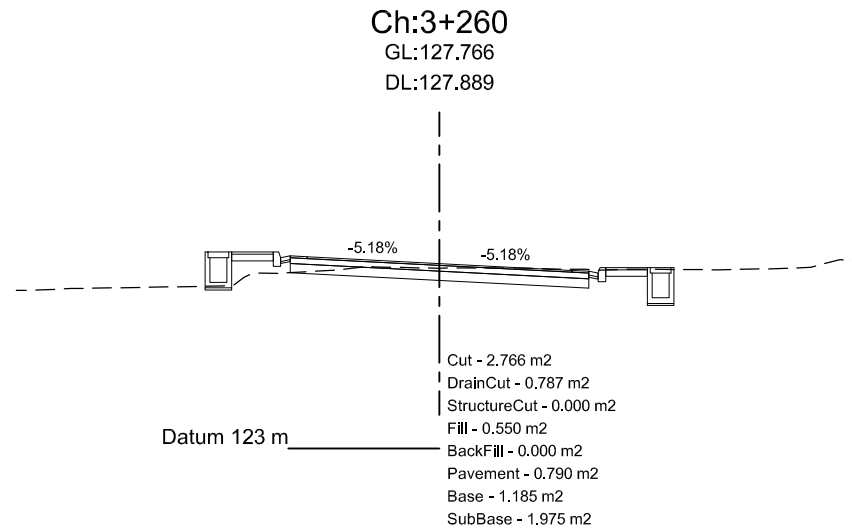
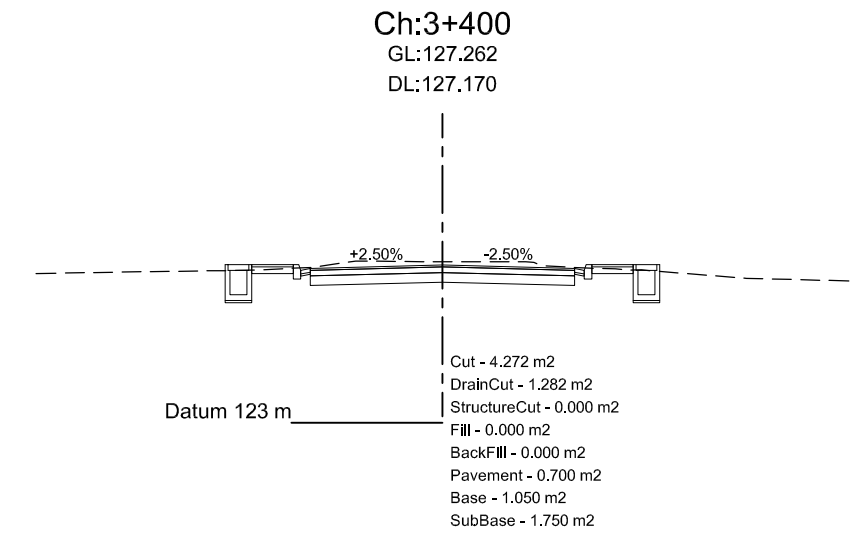
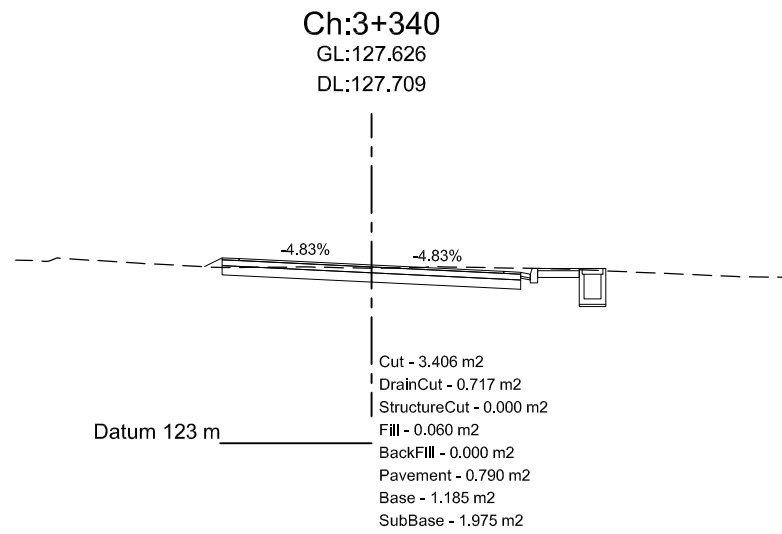
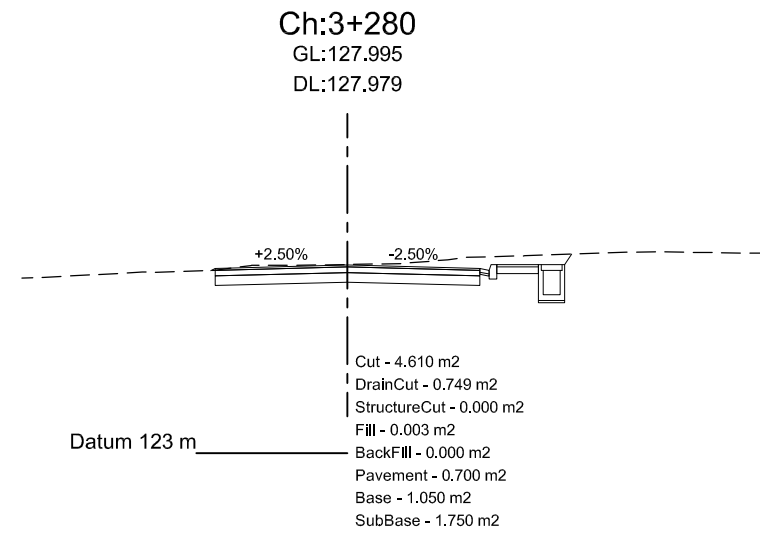

Department of Urban Development & Building
Construction (DUDBC)
Regional Urban Development Project (RUDP)
West Urban Corridor (WUC) Development Project
Babarmahal, Kathmandu, Nepal

Reviewed & Designed By :
DOHWA Engineering Co. Ltd.
in Association with
ERMIC (P.) Ltd., SILT Consultants (P.) Ltd., and
DIGICON (P.) Ltd.
Mid-Baneshwor, Kathmandu
Tel: 01-4589393

Consultant
Team Leader : YOO CHANGMIN
Reviewed By : YAGYA BAHADUR MALLA
Designed By : MANJU MUNANKARMI

Client
Approved By :
Checked By :

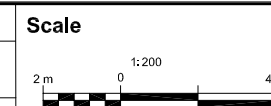

Cross-Section
BANCHAUKI-MAYADEVI PARK- MILDANDA
- BUDDHA CIRCUIT ROAD
CH 0+000 - 4+941.092 Km

REV : MAY 2024
DRG NO : DM/RD/CS/20
CHAINAGE : 3+240-3+400
SHEET NO : 20

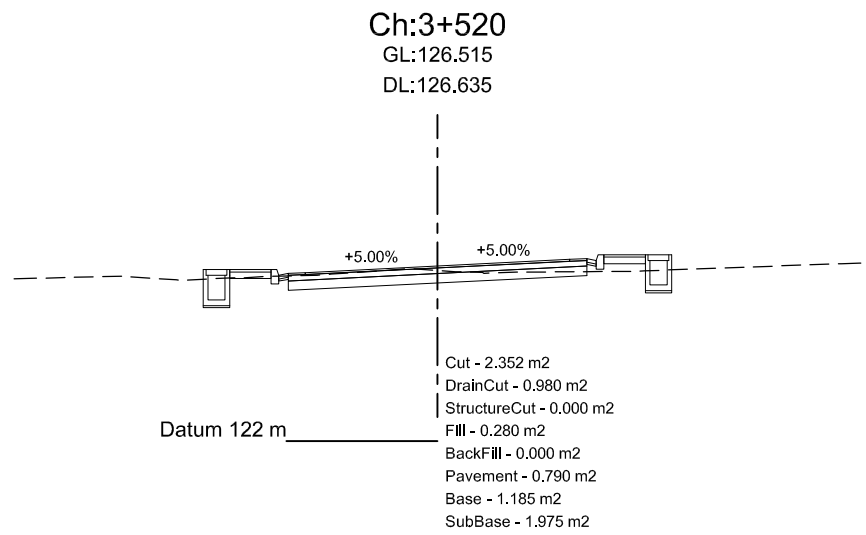
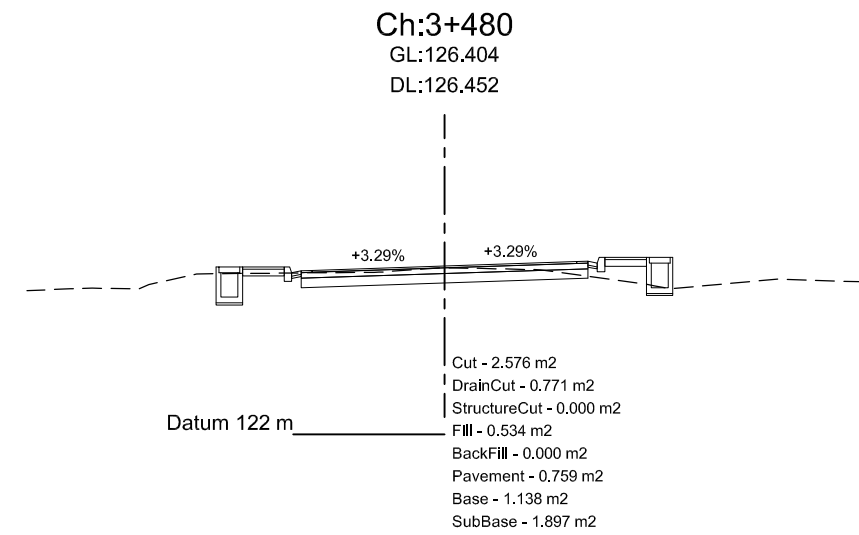
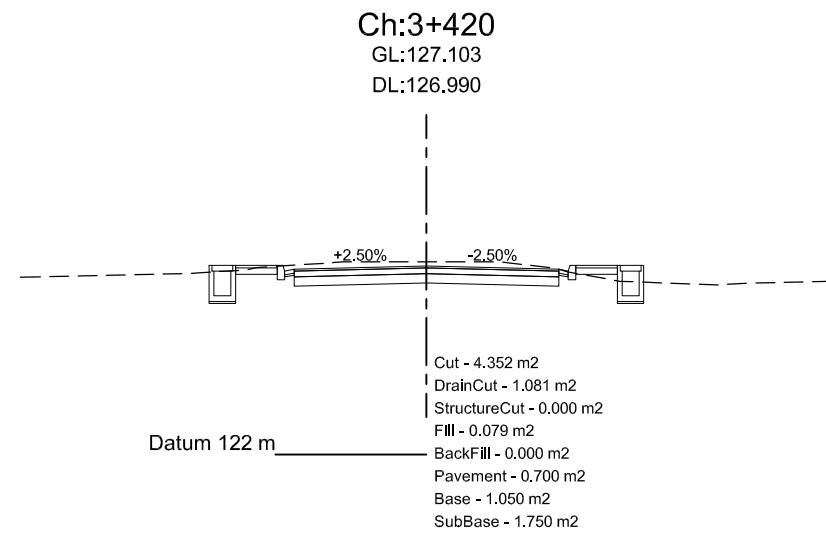
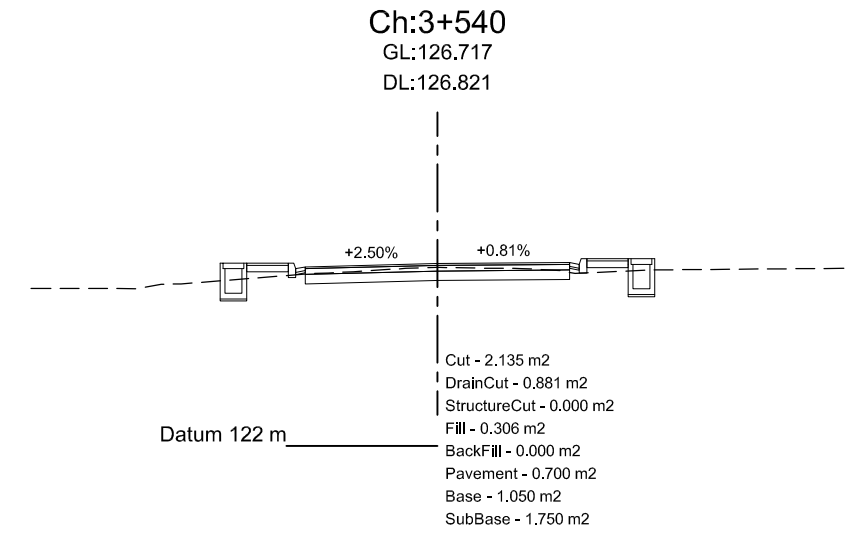
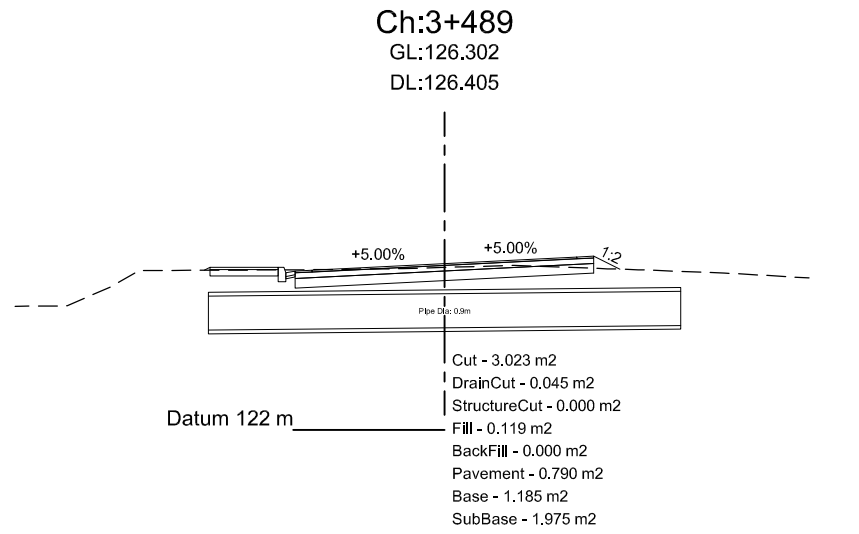
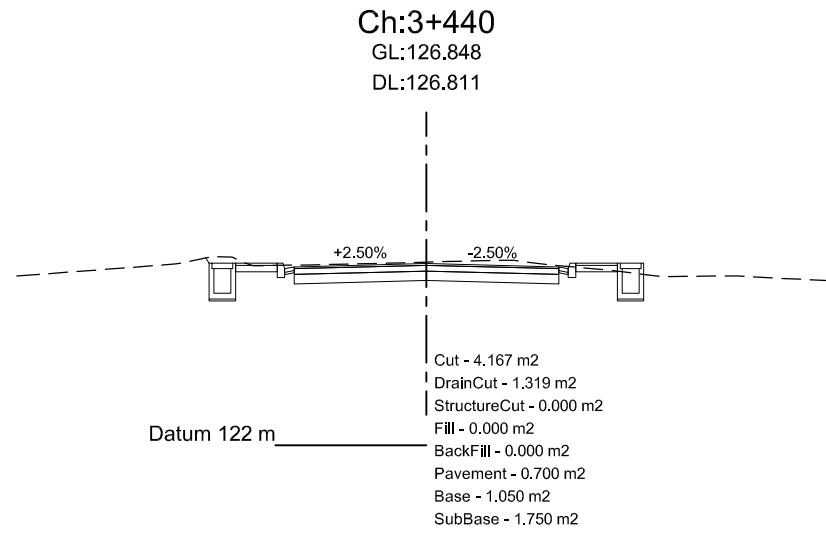
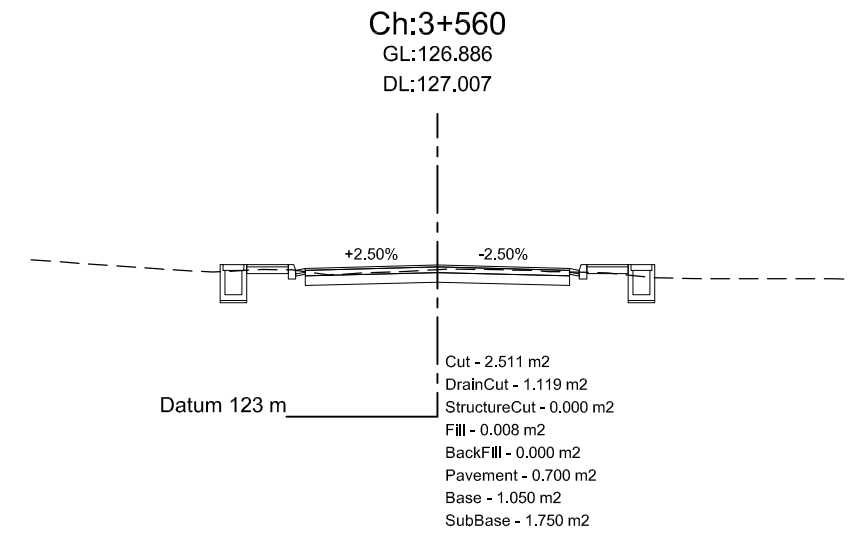
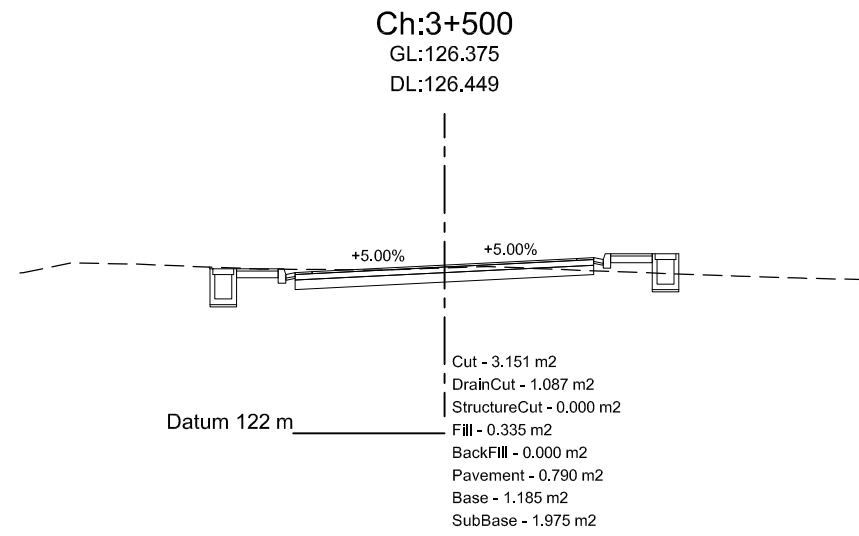
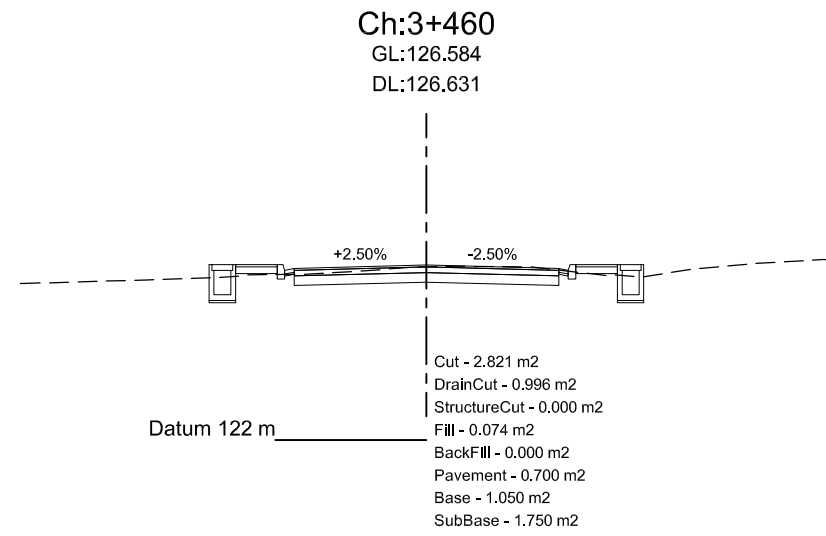

Department of Urban Development & Building Construction (DUDBC)
Regional Urban Development Project (RUDP)
West Urban Corridor (WUC) Development Project
Babarmahal, Kathmandu, Nepal

Reviewed & Designed By :
DOHWA Engineering Co. Ltd.
in Association with
ERMIC (P.) Ltd., SILT Consultants (P.) Ltd., and
DIGICON (P.) Ltd.
Mid- Baneshwor, Kathmandu
Tel: 01- 4589393

Consultant
Team Leader : YOO CHANGMIN
Reviewed By : YAGYA BAHADUR MALLA
Designed By : MANJU MUNANKARMI

Client
Approved By :
Checked By :

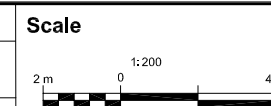

Cross-Section
BANCHAUKI-MAYADEVI PARK- MILDANDA
- BUDDHA CIRCUIT ROAD
CH 0+000 - 4+941.092 Km

REV : MAY 2024
DRG NO : DM/RD/CS/21
CHAINAGE : 3+420-3+560
SHEET NO : 21

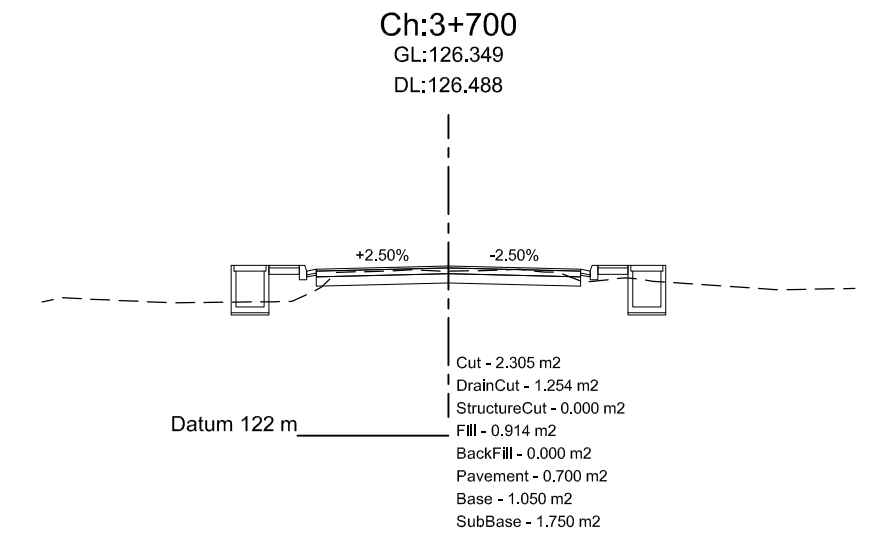
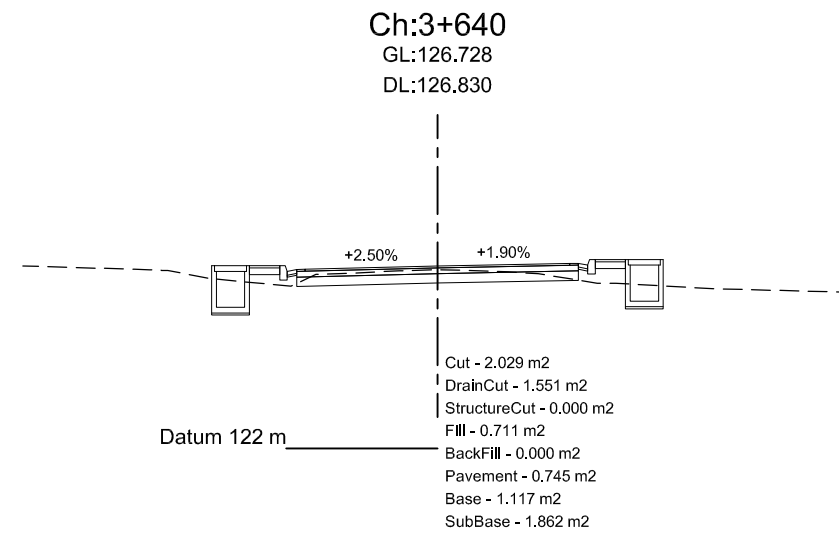
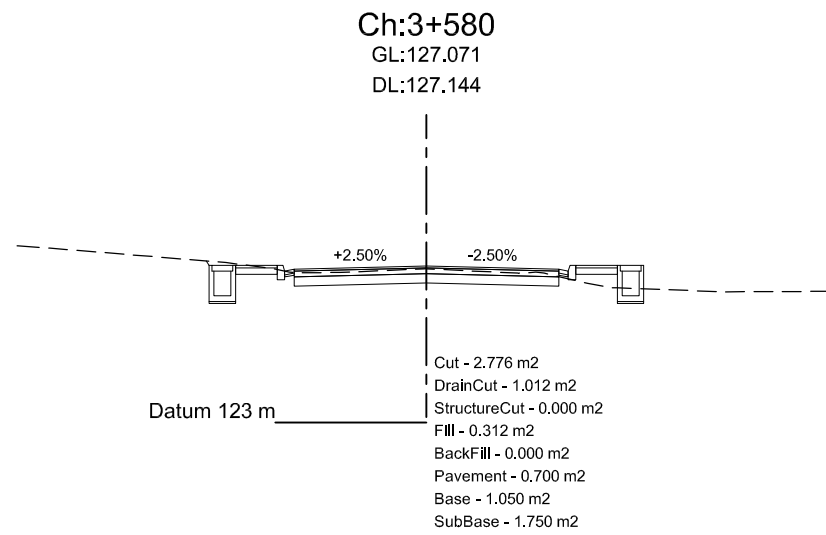
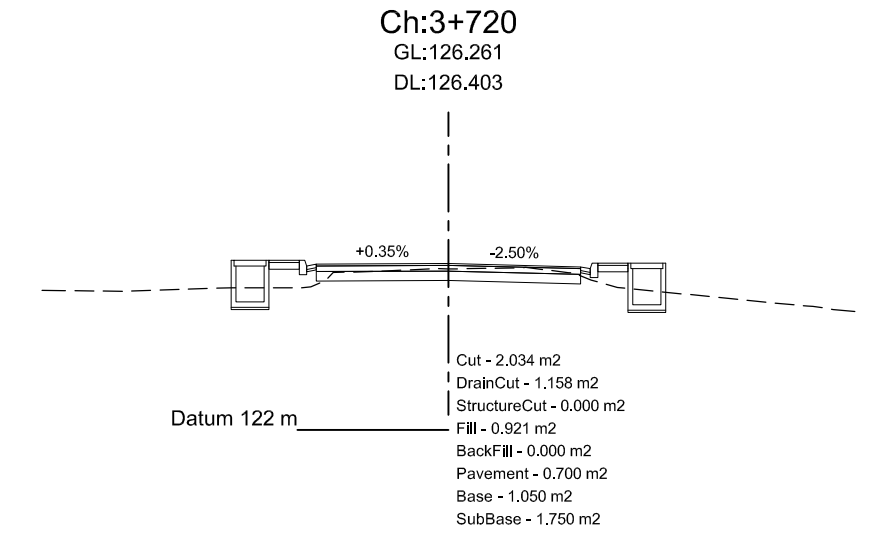
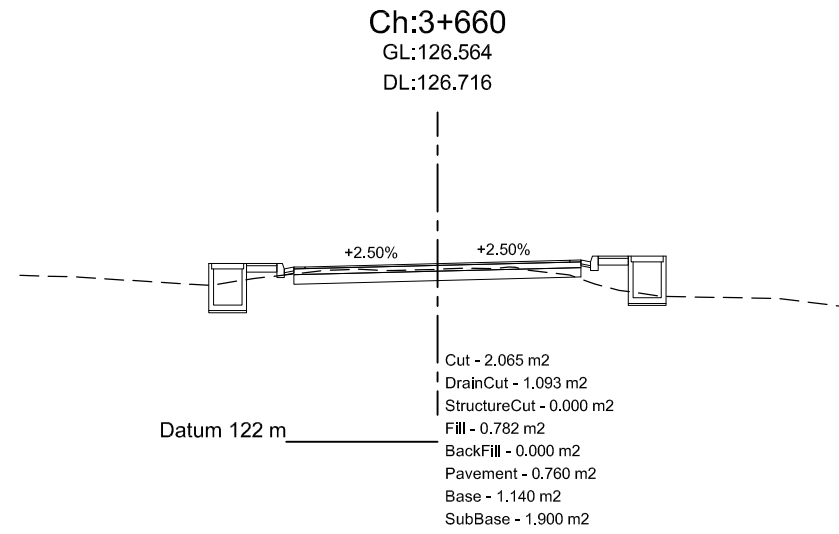
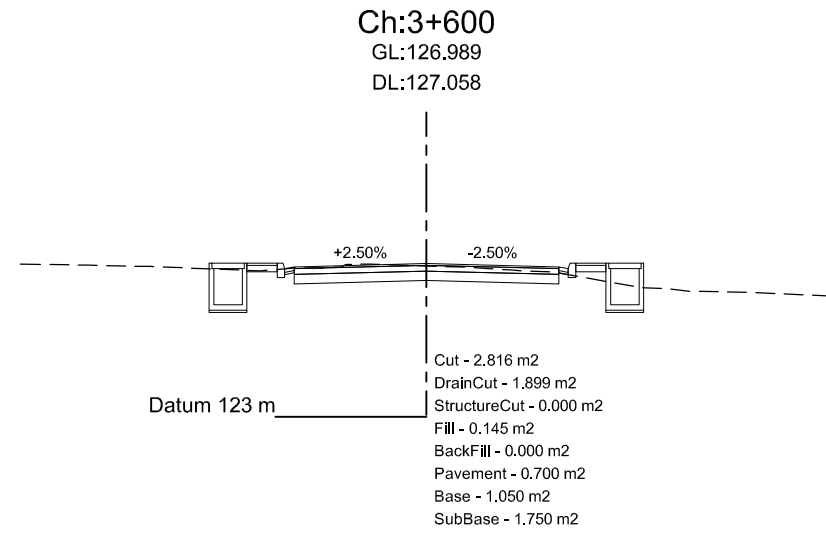
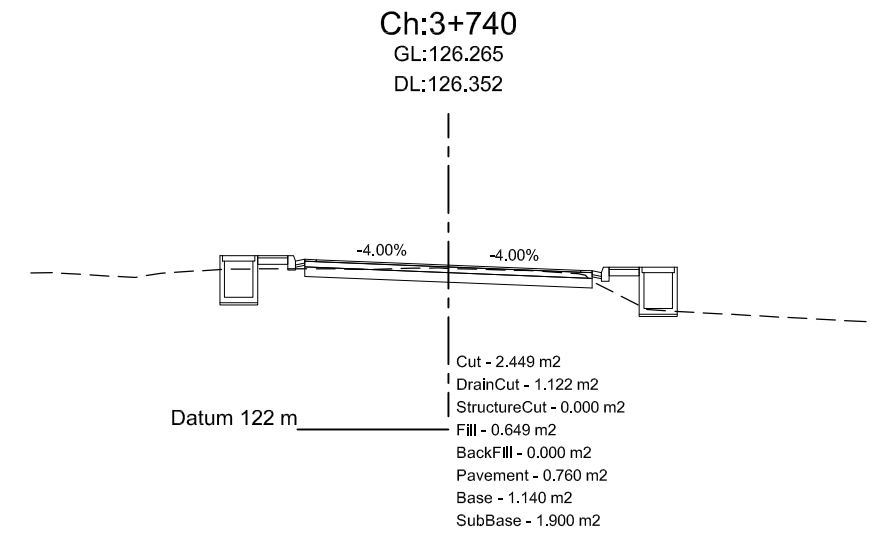
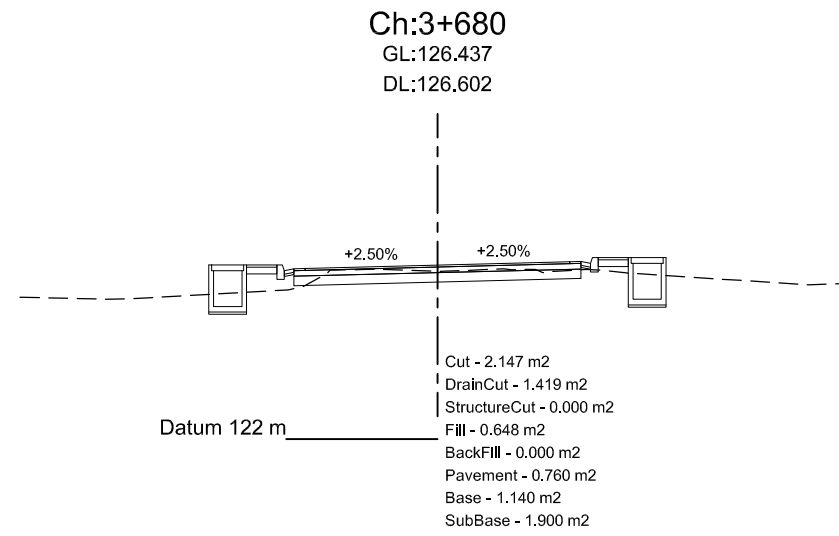
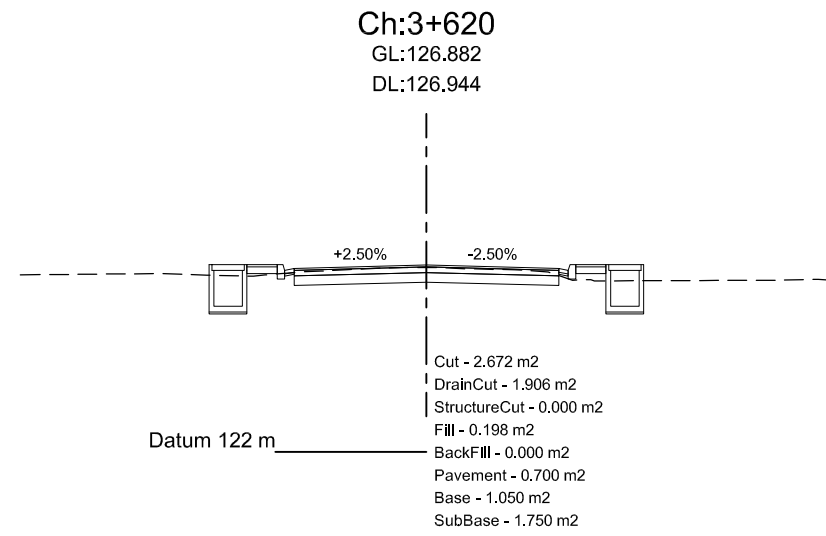

Department of Urban Development & Building
Construction (DUDBC)
Regional Urban Development Project (RUDP)
West Urban Corridor (WUC) Development Project
Babarmahal, Kathmandu, Nepal

Reviewed & Designed By :
DOHWA Engineering Co. Ltd.
in Association with
ERMIC (P.) Ltd., SILT Consultants (P.) Ltd., and
DIGICON (P.) Ltd.
Mid- Baneshwor, Kathmandu
Tel: 01- 4589393

Consultant
Team Leader : YOO CHANGMIN
Reviewed By : YAGYA BAHADUR MALLA
Designed By : MANJU MUNANKARMI

Client
Approved By :
Checked By :

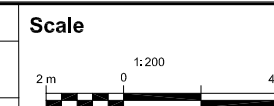

Cross-Section
BANCHAUKI-MAYADEVI PARK- MILDANDA
- BUDDHA CIRCUIT ROAD
CH 0+000 - 4+941.092 Km

REV : MAY 2024
DRG NO : DM/RD/CS/22
CHAINAGE : 3+580-3+740
SHEET NO : 22

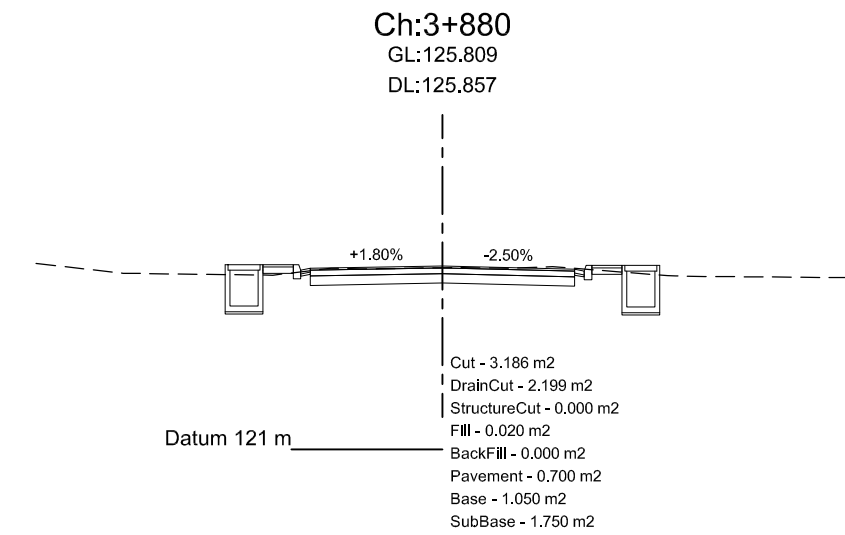
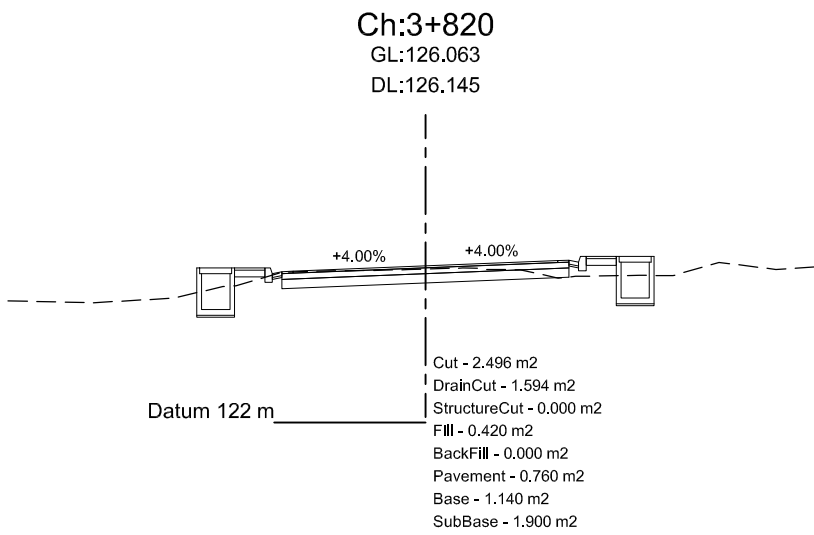
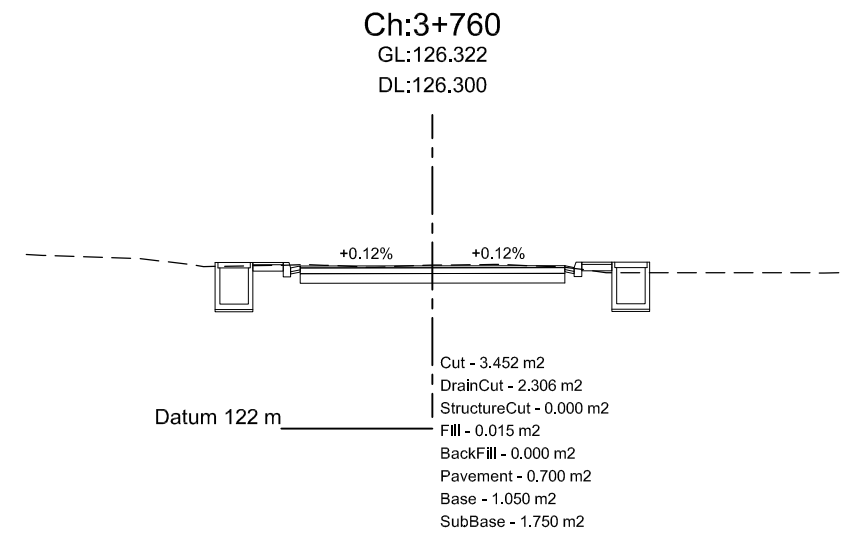
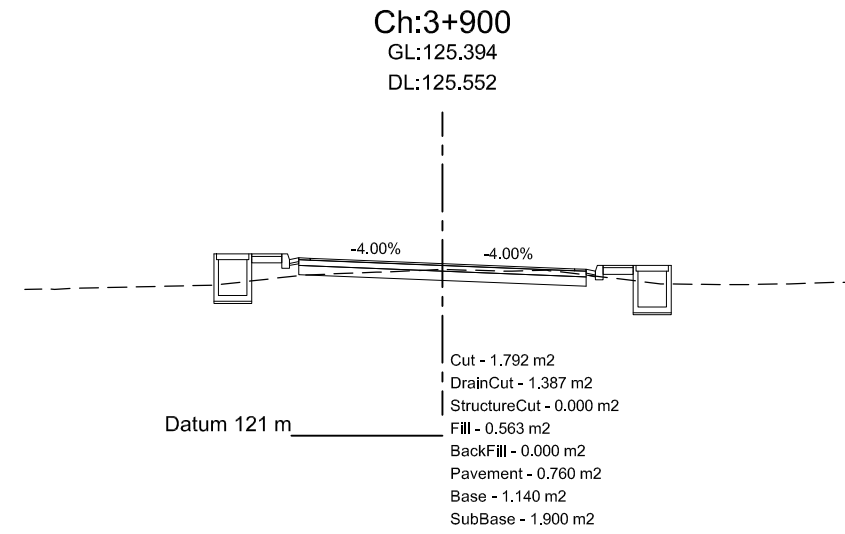
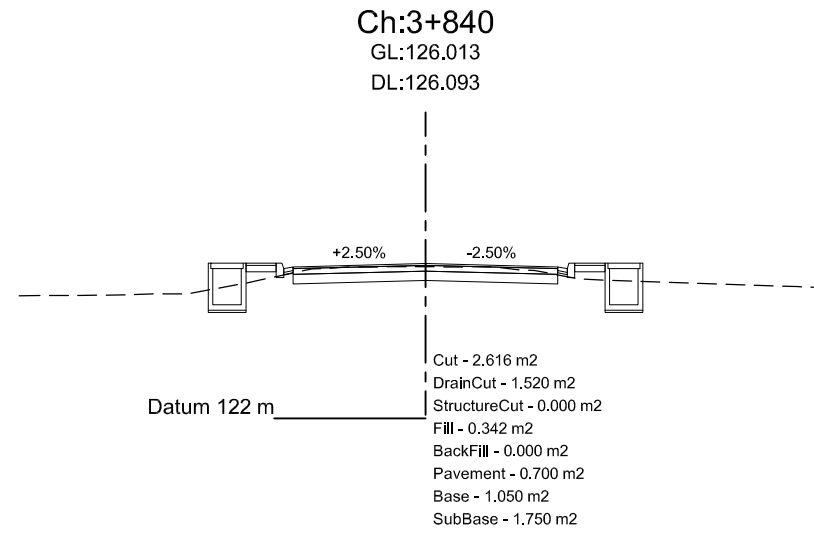
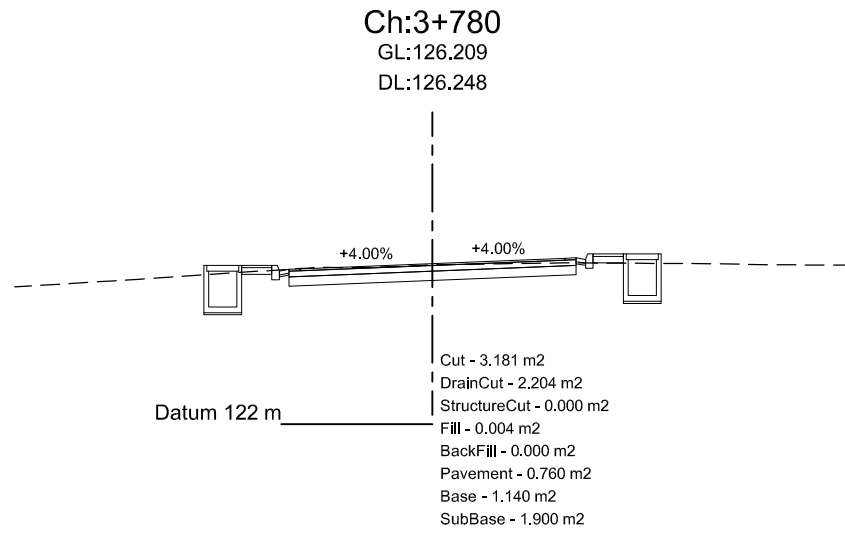
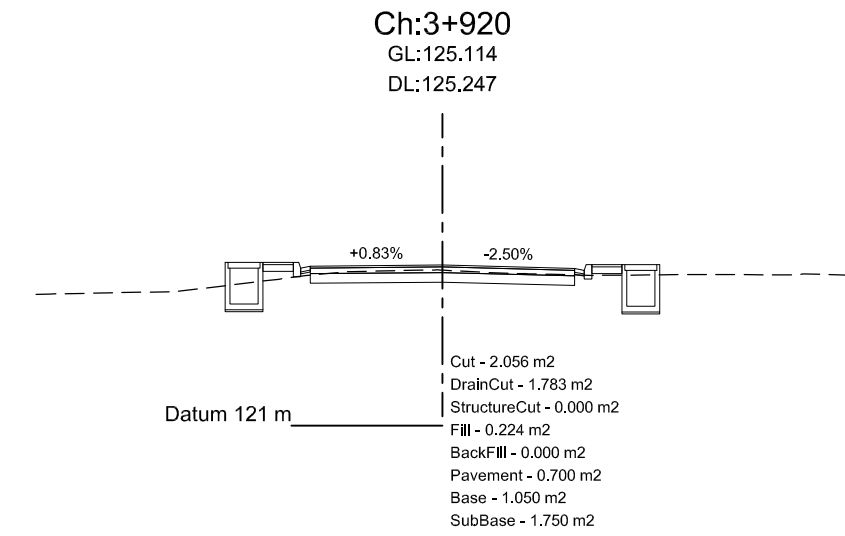
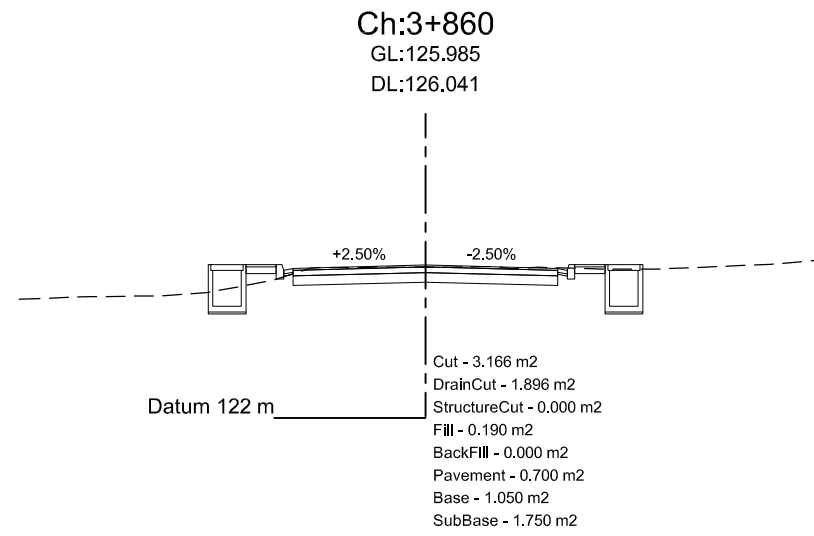
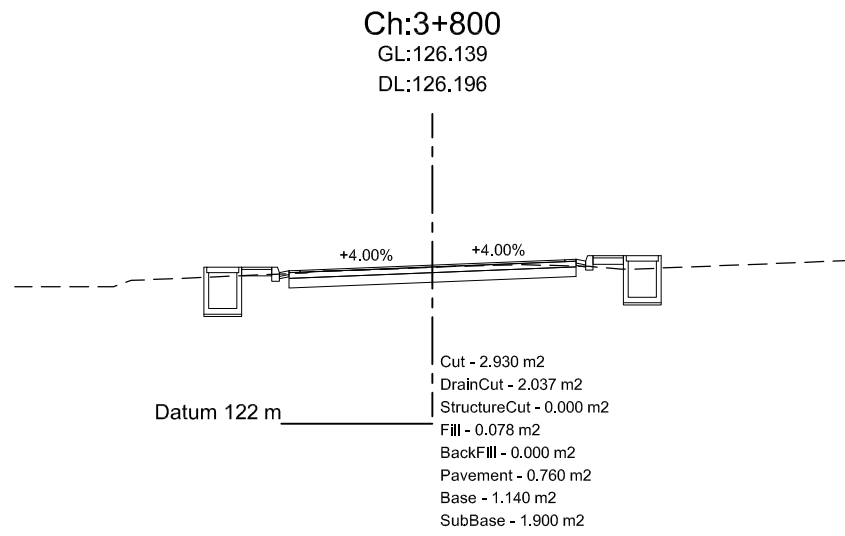

Department of Urban Development & Building
Construction (DUDBC)
Regional Urban Development Project (RUDP)
West Urban Corridor (WUC) Development Project
Babarmahal, Kathmandu, Nepal

Reviewed & Designed By :
DOHWA Engineering Co. Ltd.
in Association with
ERMIC (P.) Ltd., SILT Consultants (P.) Ltd., and
DIGICON (P.) Ltd.
Mid-Baneshwor, Kathmandu
Tel: 01-4589393

Consultant
Team Leader : YOO CHANGMIN
Reviewed By : YAGYA BAHADUR MALLA
Designed By : MANJU MUNANKARMI

Client
Approved By :
Checked By :

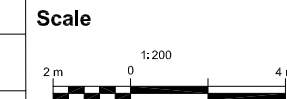

Cross-Section
BANCHAUKI-MAYADEVI PARK- MILDANDA
- BUDDHA CIRCUIT ROAD
CH 0+000 - 4+941.092 Km

REV : MAY 2024
DRG NO : DM/RD/CS/23
CHAINAGE : 3+760-3+920
SHEET NO : 23

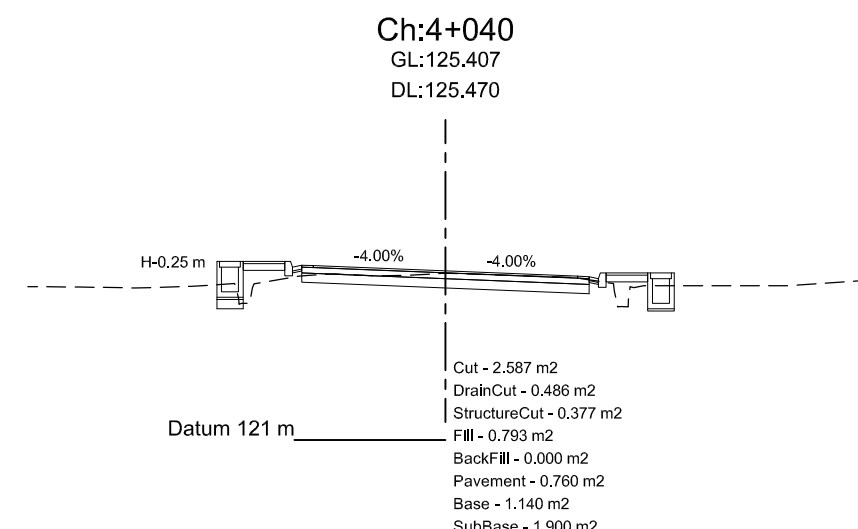
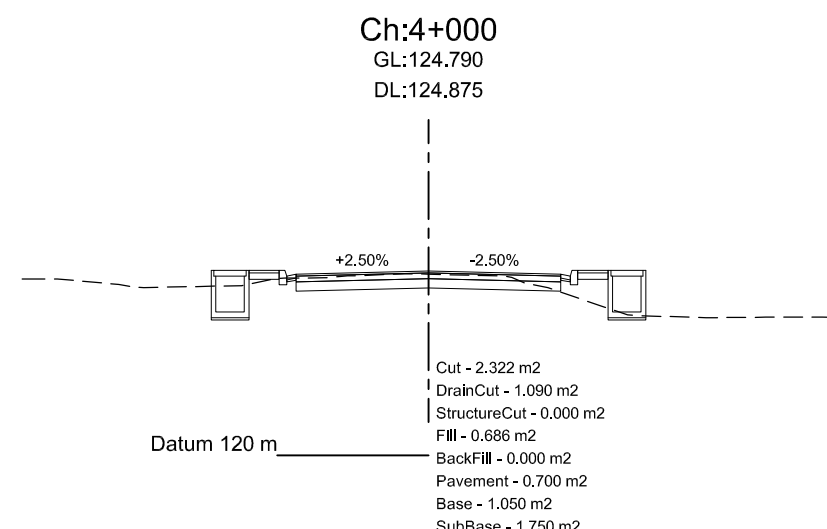
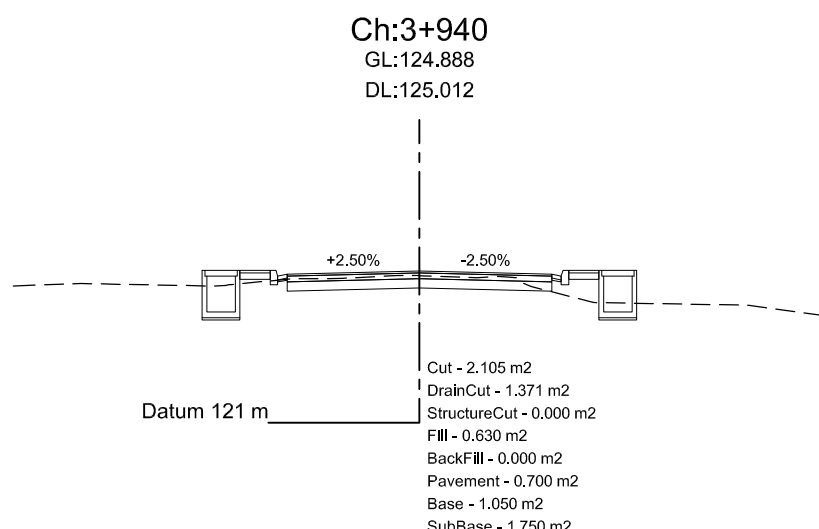
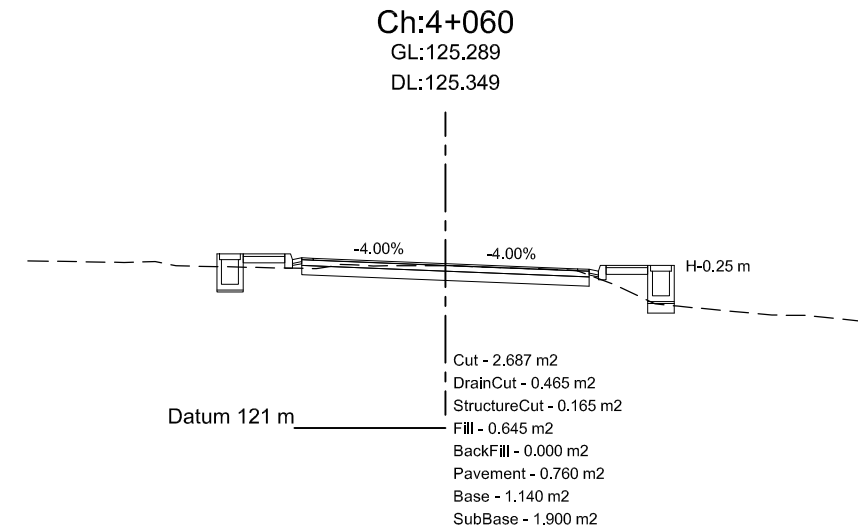
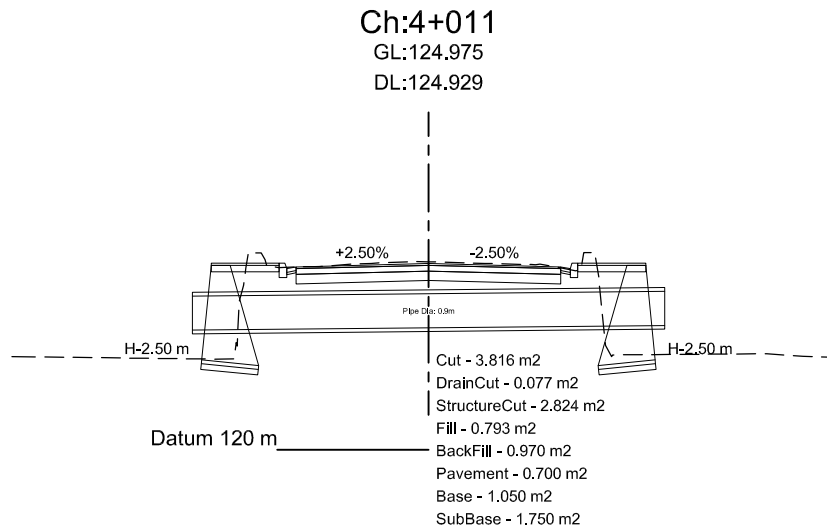
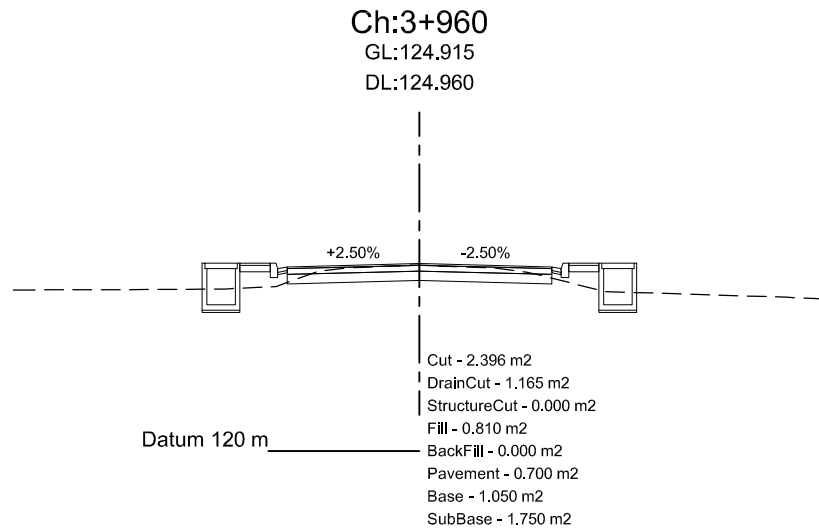
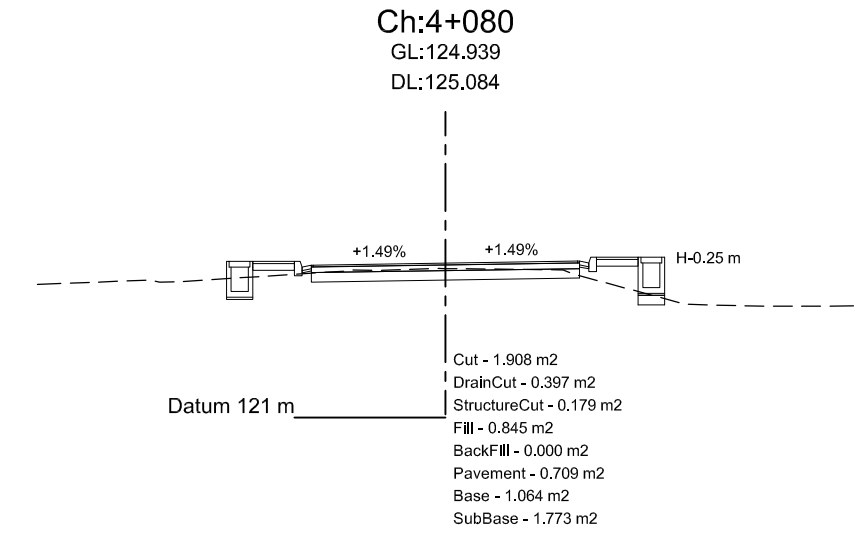
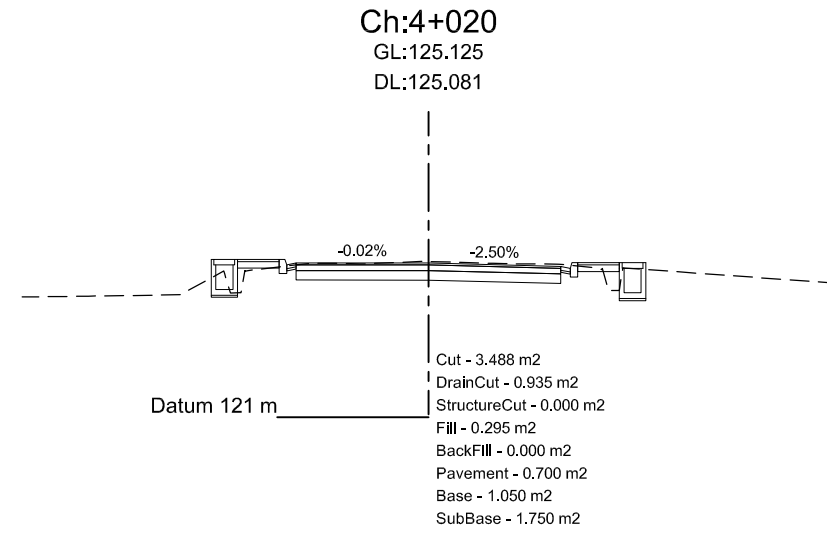
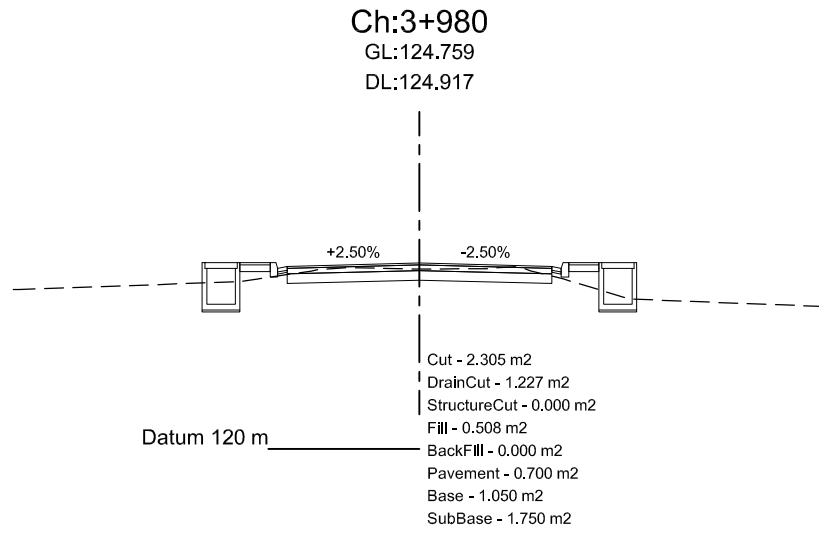

Department of Urban Development & Building Construction (DUDBC)
Regional Urban Development Project (RUDP)
West Urban Corridor (WUC) Development Project
Babarmahal, Kathmandu, Nepal

Reviewed & Designed By :
DOHWA Engineering Co. Ltd.
in Association with
ERMIC (P.) Ltd., SILT Consultants (P.) Ltd., and
DIGICON (P.) Ltd.
Mid- Baneshwor, Kathmandu
Tel: 01- 4589393

Consultant
Team Leader : YOO CHANGMIN
Reviewed By : YAGYA BAHADUR MALLA
Designed By : MANJU MUNANKARMI

Client
Approved By :
Checked By :

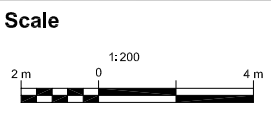

Cross-Section
BANCHAUKI-MAYADEVI PARK- MILDANDA
- BUDDHA CIRCUIT ROAD
CH 0+000 - 4+941.092 Km

REV : MAY 2024
DRG NO : DM/RD/CS/24
CHAINAGE : 3+940-4+080
SHEET NO : 24

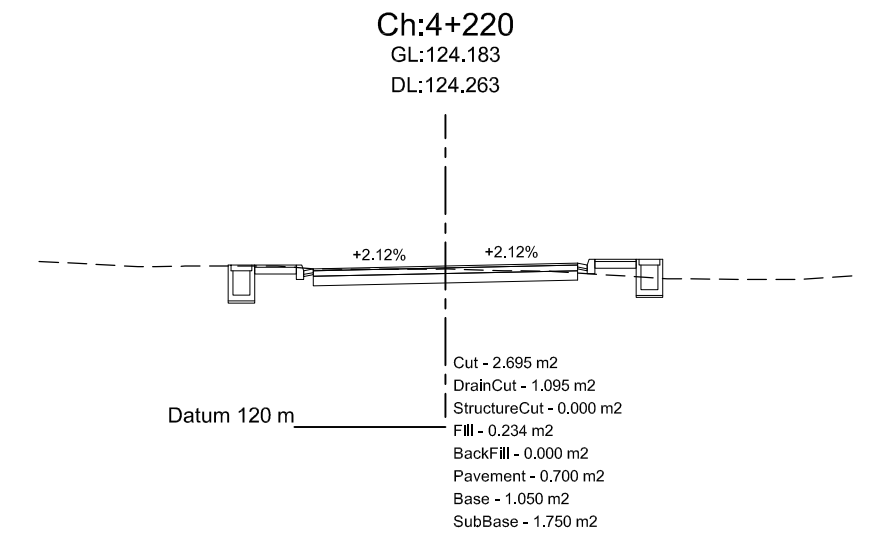
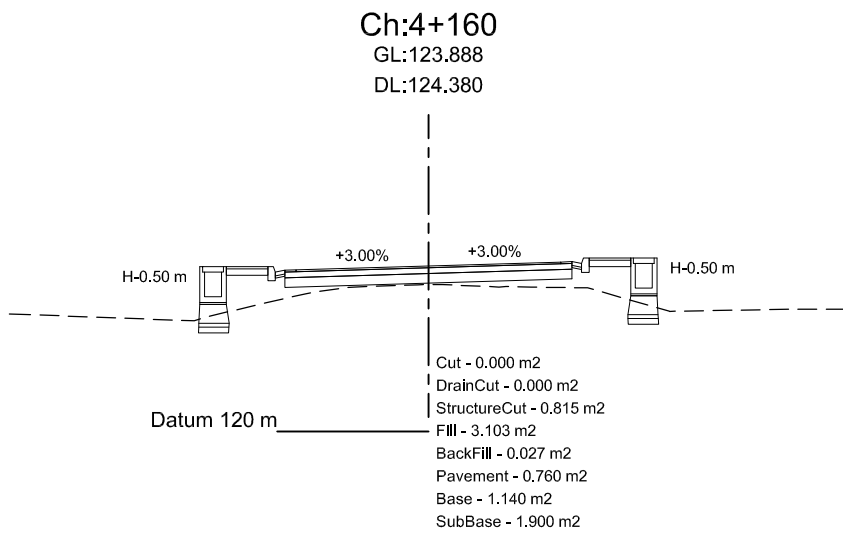
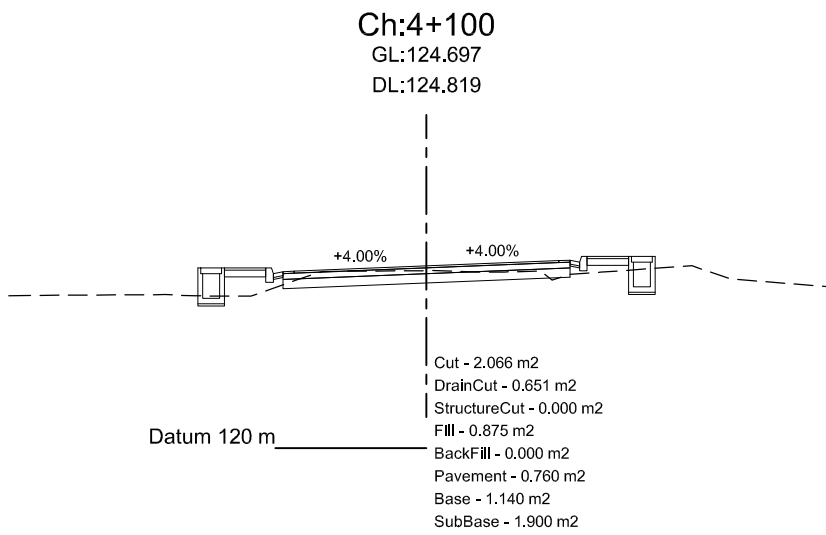
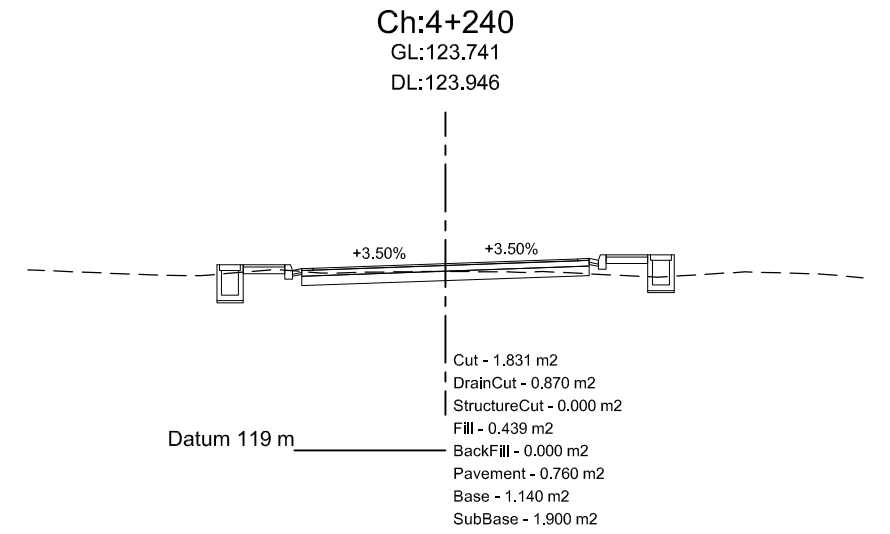
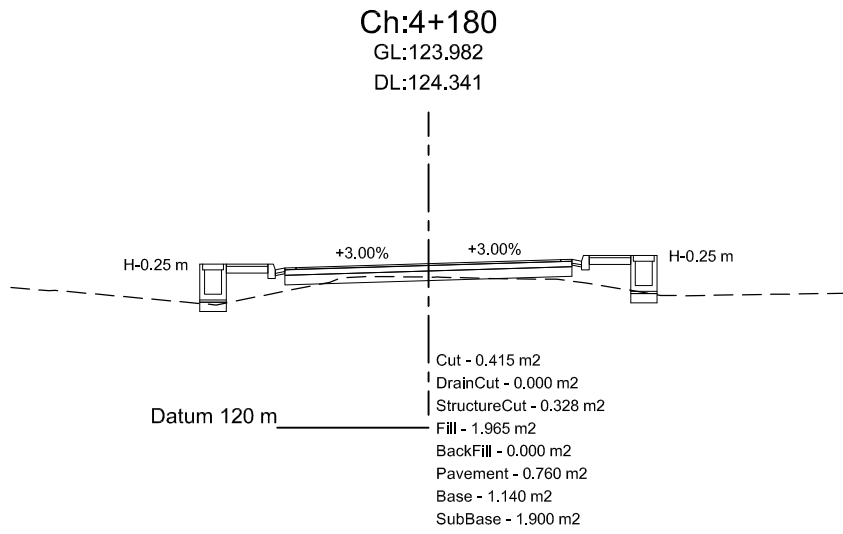
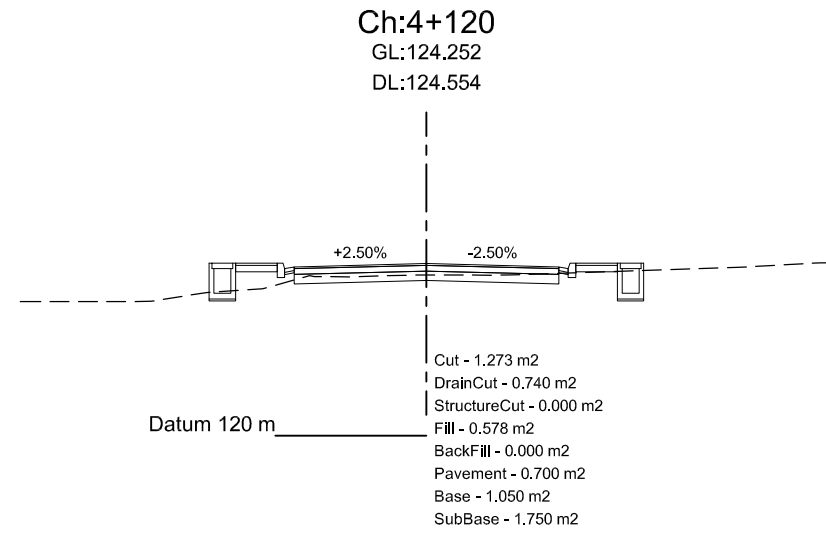
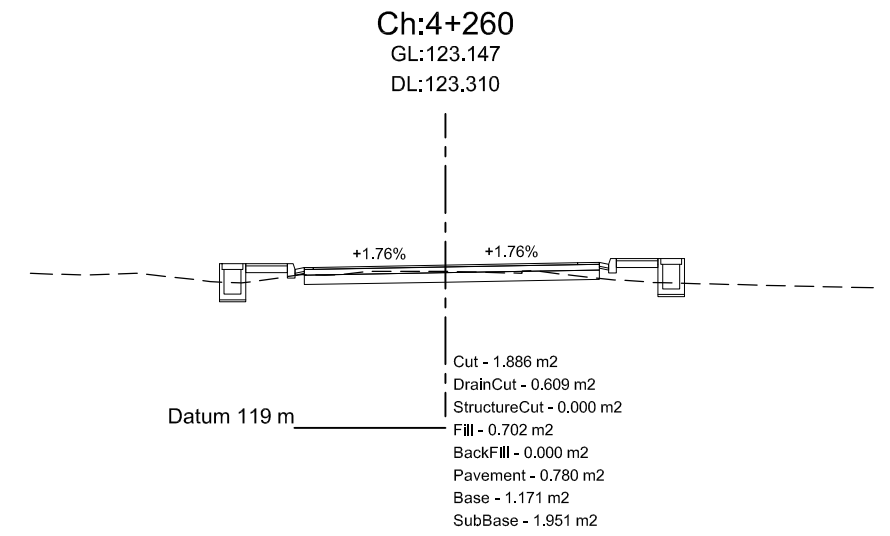
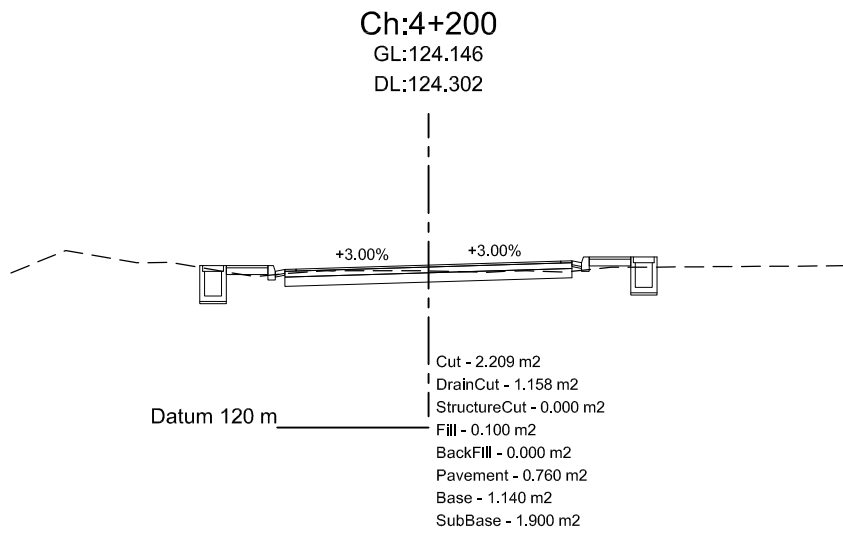
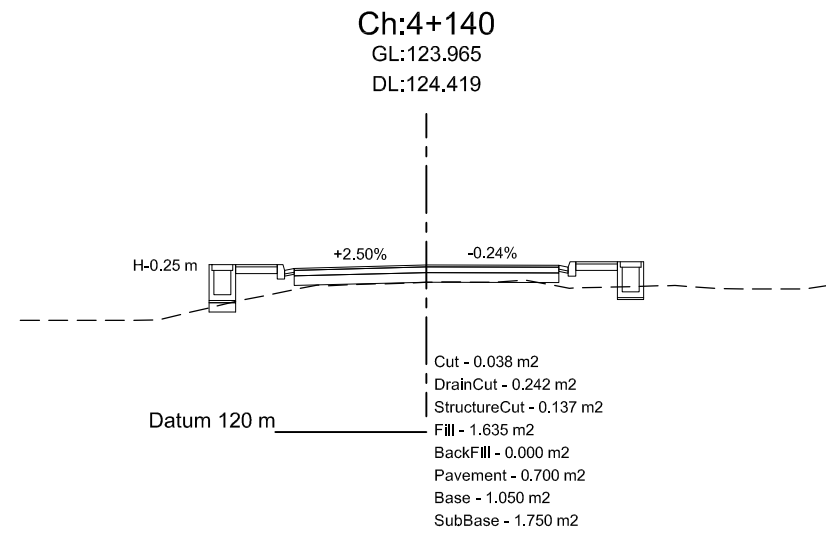

Department of Urban Development & Building
Construction (DUDBC)
Regional Urban Development Project (RUDP)
West Urban Corridor (WUC) Development Project
Babarmahal, Kathmandu, Nepal

Reviewed & Designed By :
DOHWA Engineering Co. Ltd.
in Association with
ERMIC (P.) Ltd., SILT Consultants (P.) Ltd., and
DIGICON (P.) Ltd.
Mid- Baneshwor, Kathmandu
Tel: 01- 4589393

Consultant
Team Leader : YOO CHANGMIN
Reviewed By : YAGYA BAHADUR MALLA
Designed By : MANJU MUNANKARMI

Client
Approved By :
Checked By :

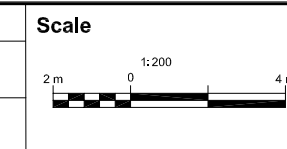

Cross-Section
BANCHAUKI-MAYADEVI PARK- MILDANDA
- BUDDHA CIRCUIT ROAD
CH 0+000 - 4+941.092 Km

REV : MAY 2024
DRG NO : DM/RD/CS/25
CHAINAGE : 4+100-4+260
SHEET NO : 25

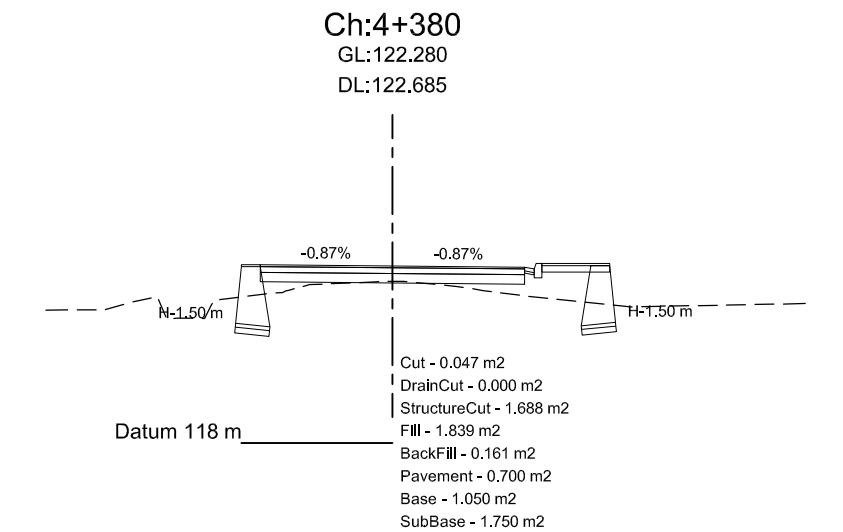
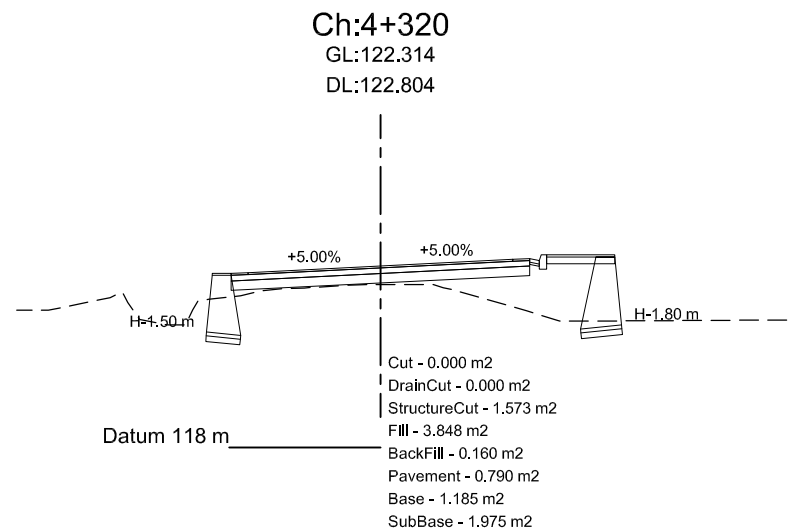
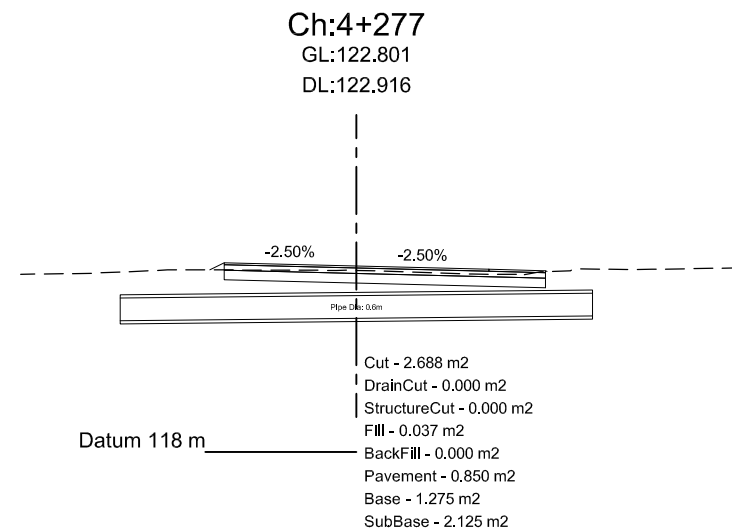
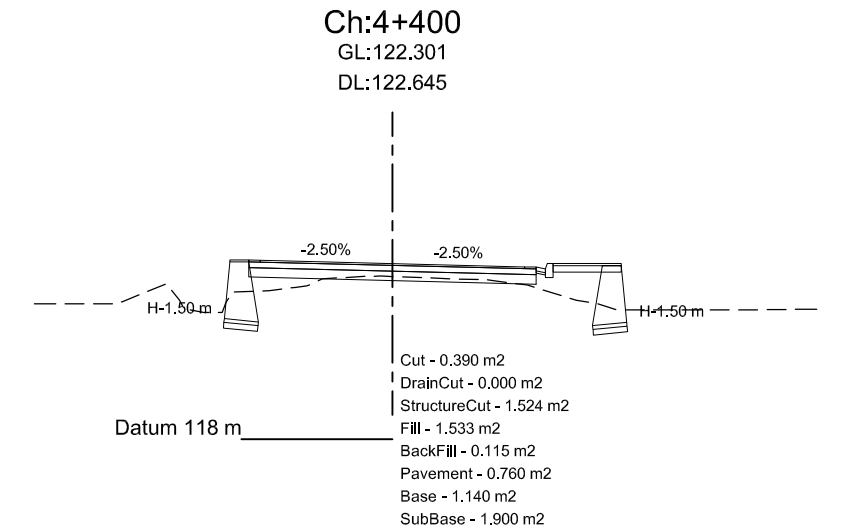
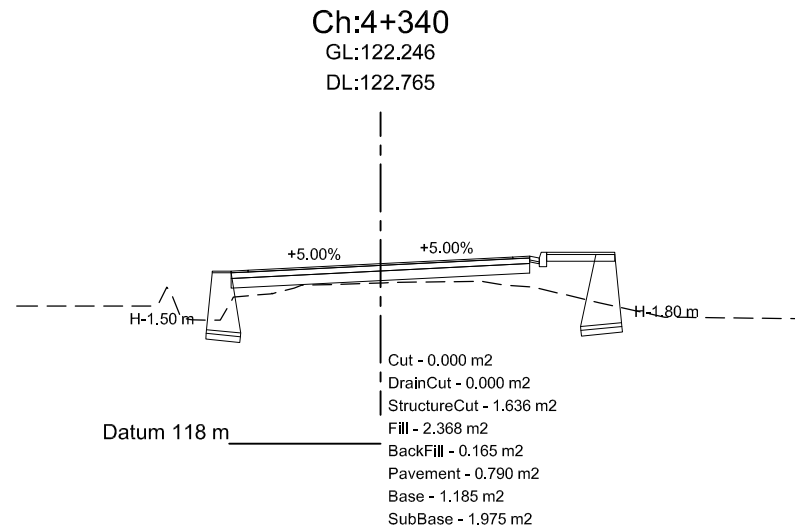
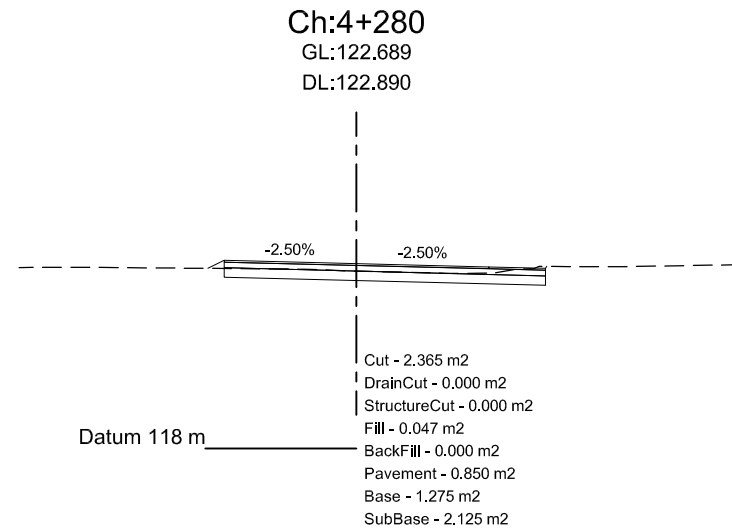
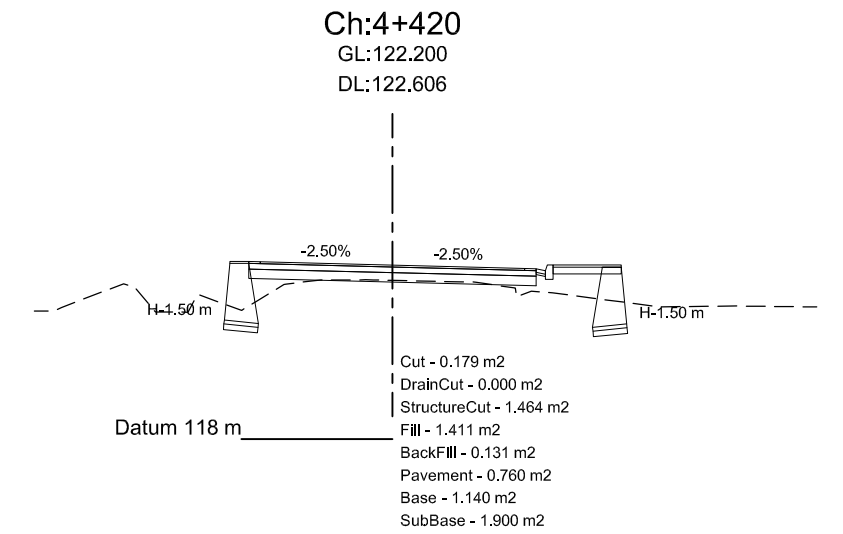
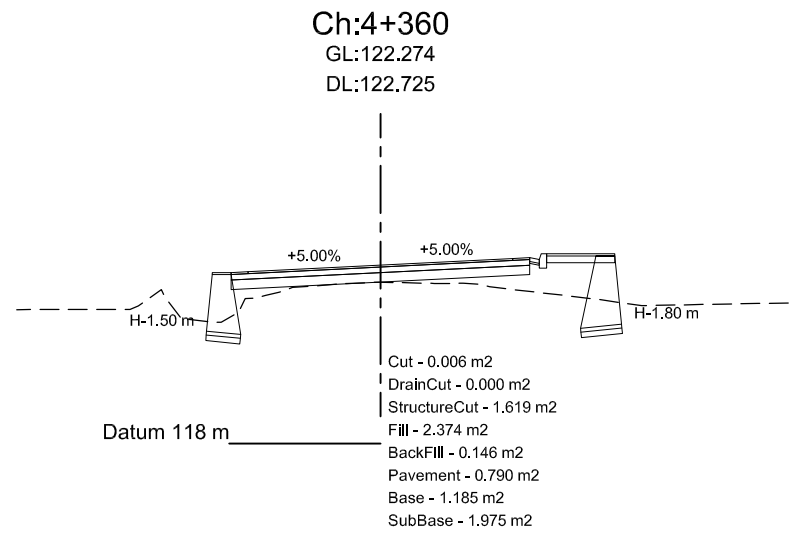
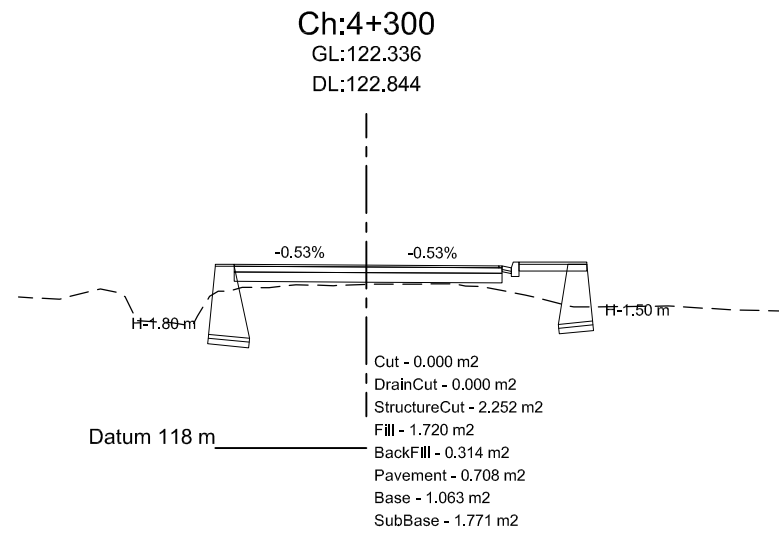

Department of Urban Development & Building
Construction (DUDBC)
Regional Urban Development Project (RUDP)
West Urban Corridor (WUC) Development Project
Babarmahal, Kathmandu, Nepal

Reviewed & Designed By :
DOHWA Engineering Co. Ltd.
in Association with
ERMIC (P.) Ltd., SILT Consultants (P.) Ltd., and
DIGICON (P.) Ltd.
Mid- Baneshwor, Kathmandu
Tel: 01- 4589393

Consultant
Team Leader : YOO CHANGMIN
Reviewed By : YAGYA BAHADUR MALLA
Designed By : MANJU MUNANKARMI

Client
Approved By :
Checked By :

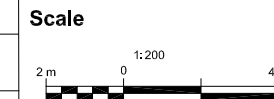

Cross-Section
BANCHAUKI-MAYADEVI PARK- MILDANDA
- BUDDHA CIRCUIT ROAD
CH 0+000 - 4+941.092 Km

REV : MAY 2024
DRG NO : DM/RD/CS/26
CHAINAGE : 4+270-4+420
SHEET NO : 26

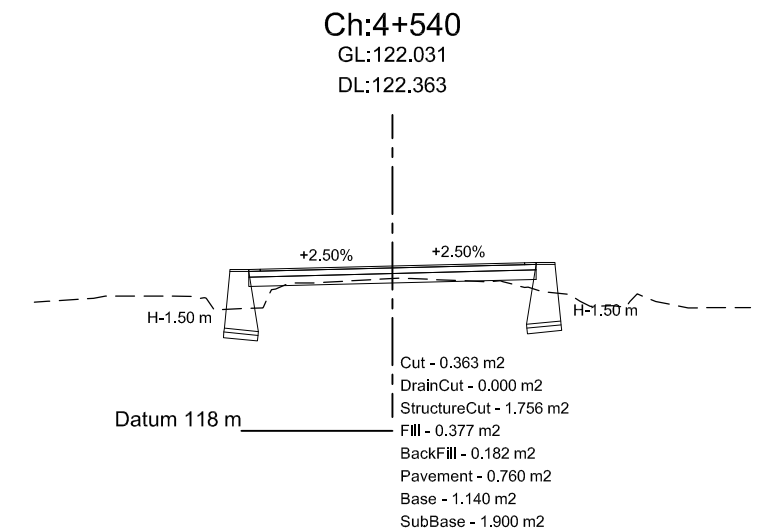
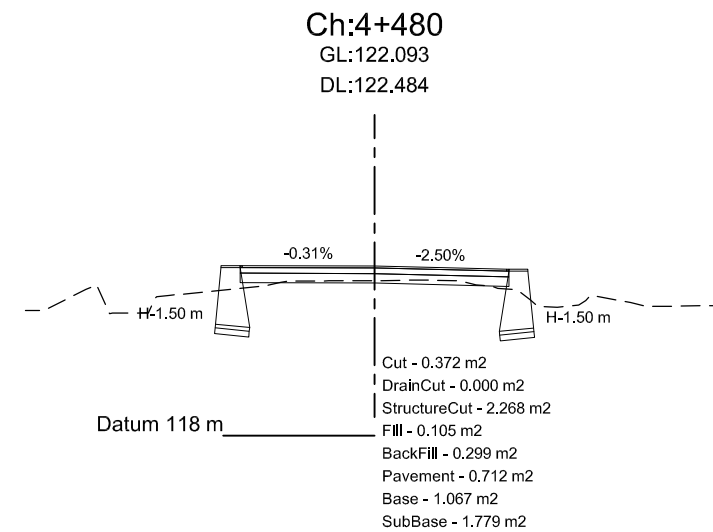
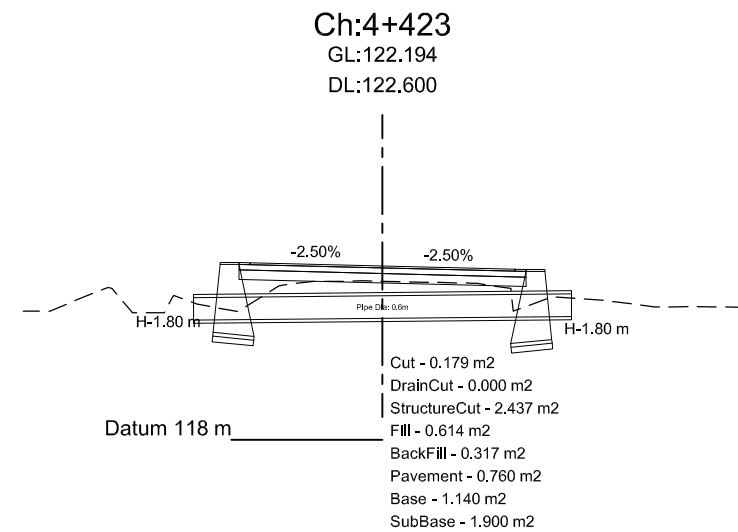
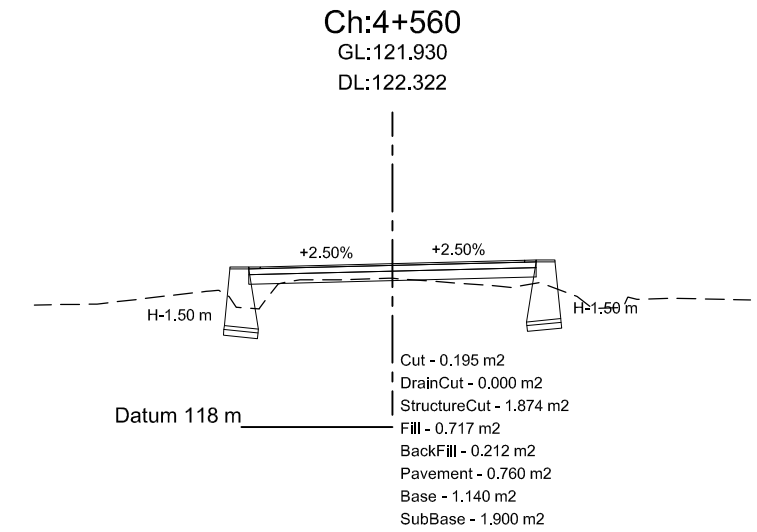
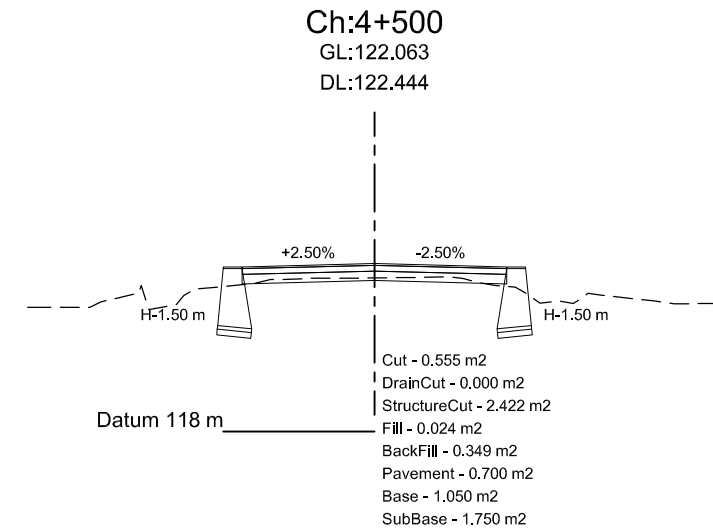
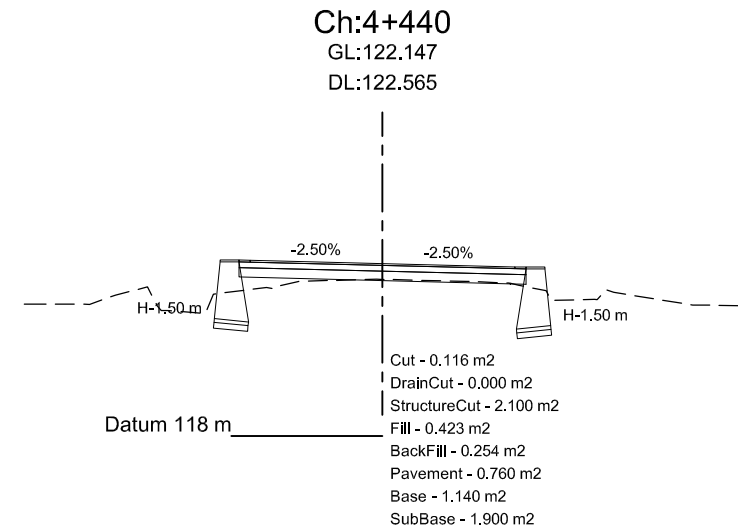
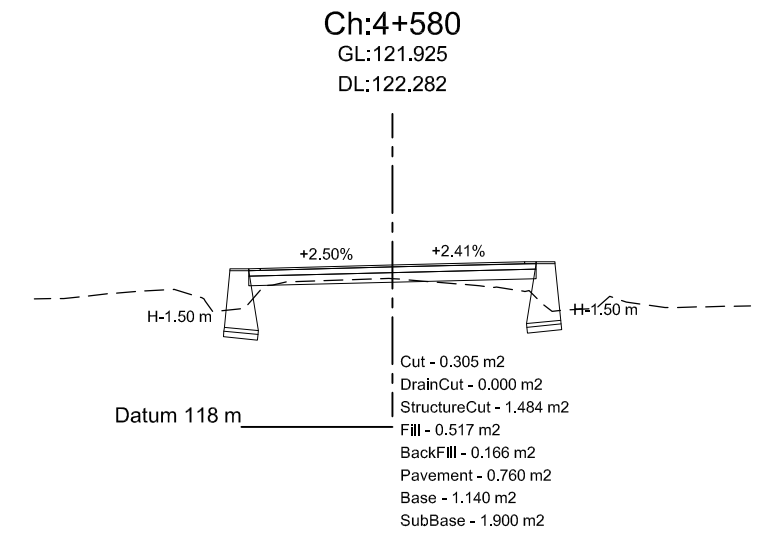
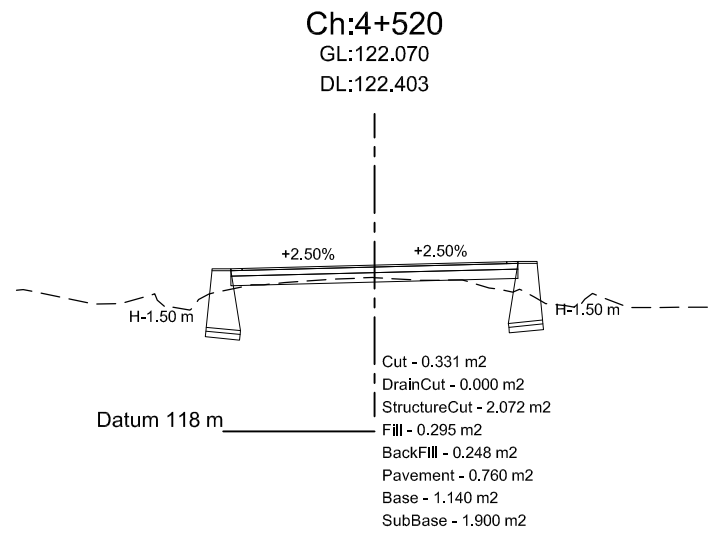
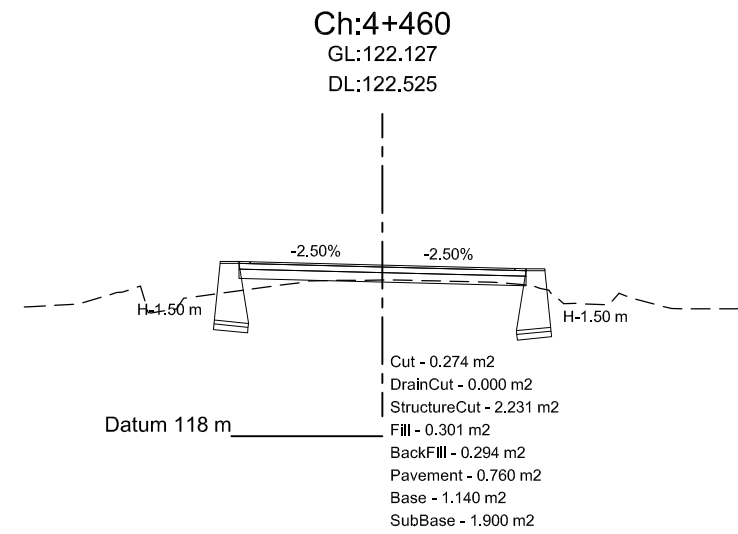

Department of Urban Development & Building
Construction (DUDBC)
Regional Urban Development Project (RUDP)
West Urban Corridor (WUC) Development Project
Babarmahal, Kathmandu, Nepal

Reviewed & Designed By :
DOHWA Engineering Co. Ltd.
in Association with
ERMIC (P.) Ltd., SILT Consultants (P.) Ltd., and
DIGICON (P.) Ltd.
Mid- Baneshwor, Kathmandu
Tel: 01-4589393

Consultant
Team Leader : YOO CHANGMIN
Reviewed By : YAGYA BAHADUR MALLA
Designed By : MANJU MUNANKARMI

Client
Approved By :
Checked By :



Cross-Section
BANCHAUKI-MAYADEVI PARK- MILDANDA
- BUDDHA CIRCUIT ROAD
CH 0+000 - 4+941.092 Km

REV : MAY 2024
DRG NO : DM/RD/CS/27
CHAINAGE : 4+423-4+580
SHEET NO : 27

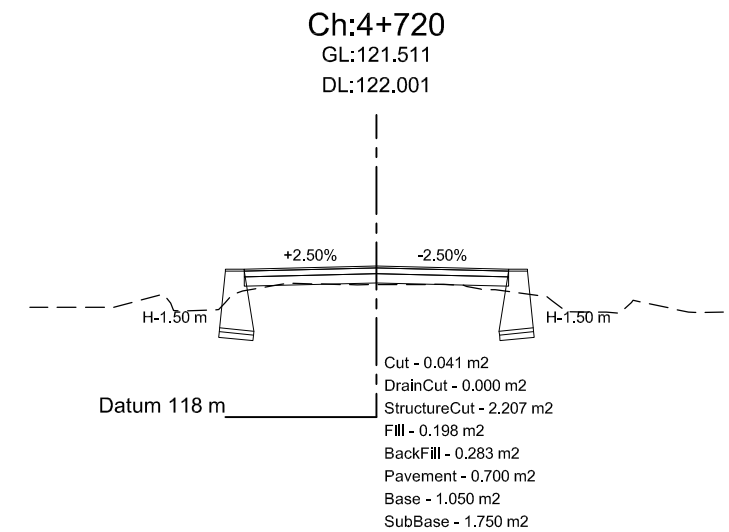
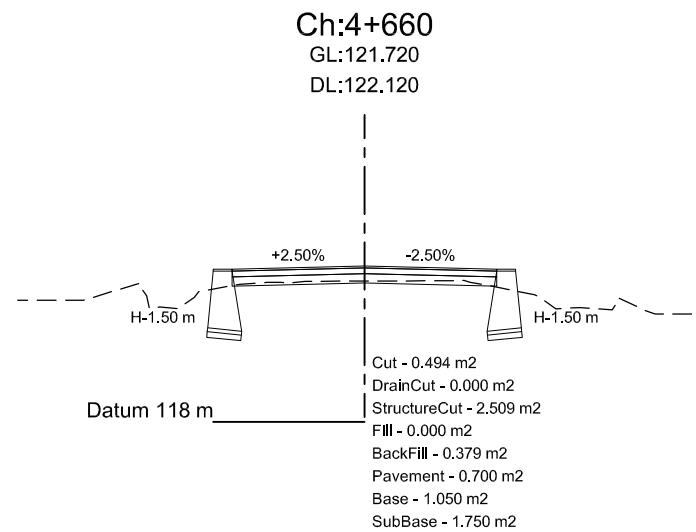
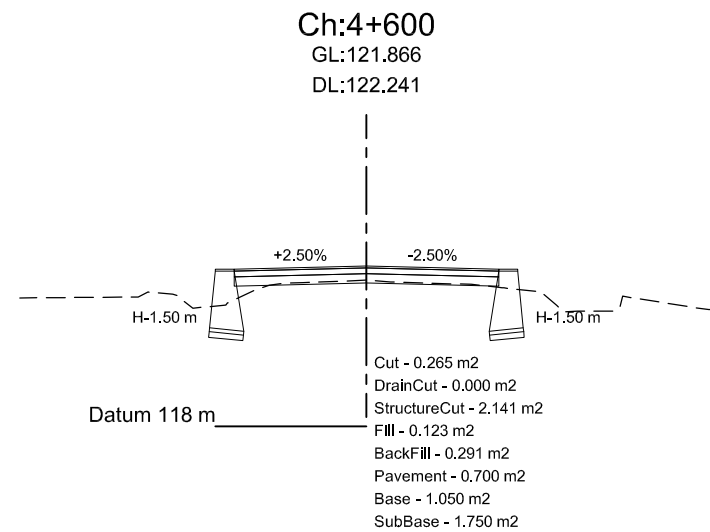
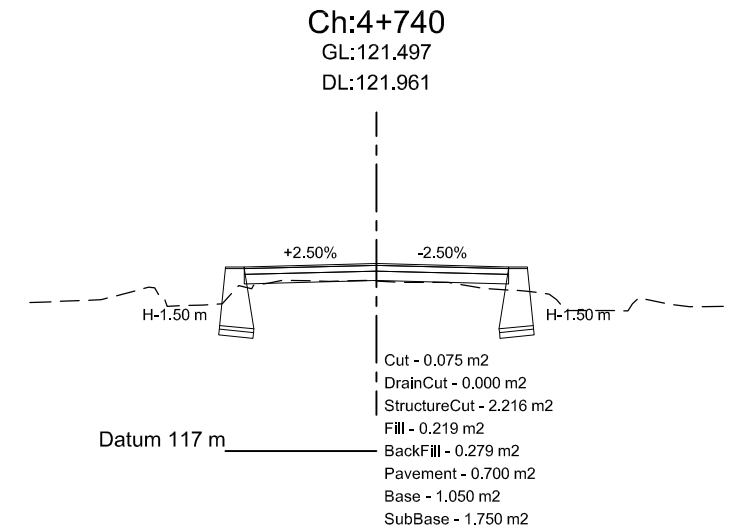
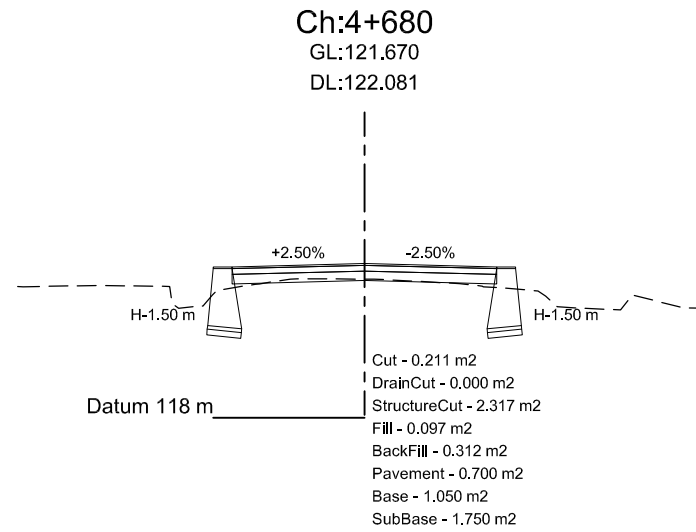
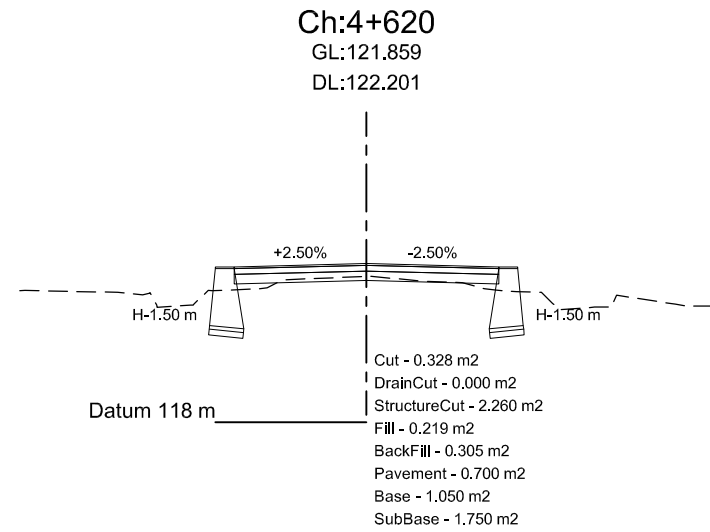
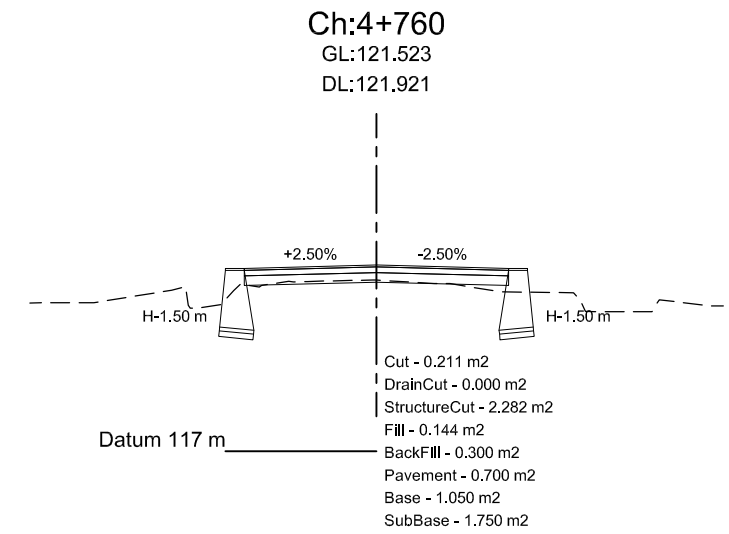
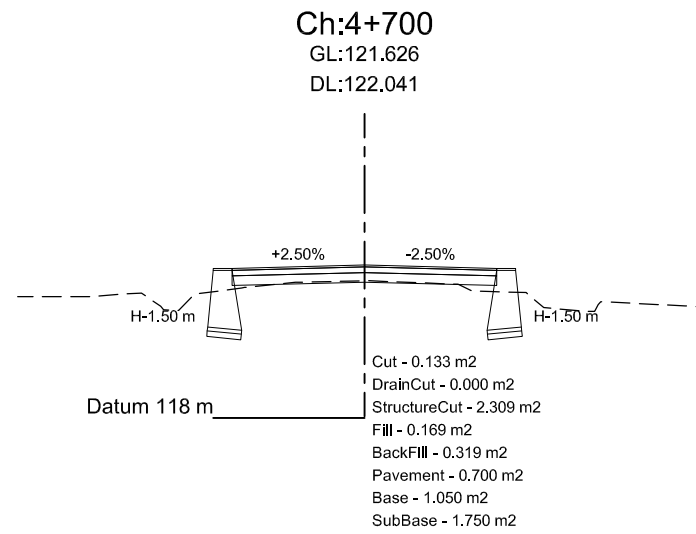
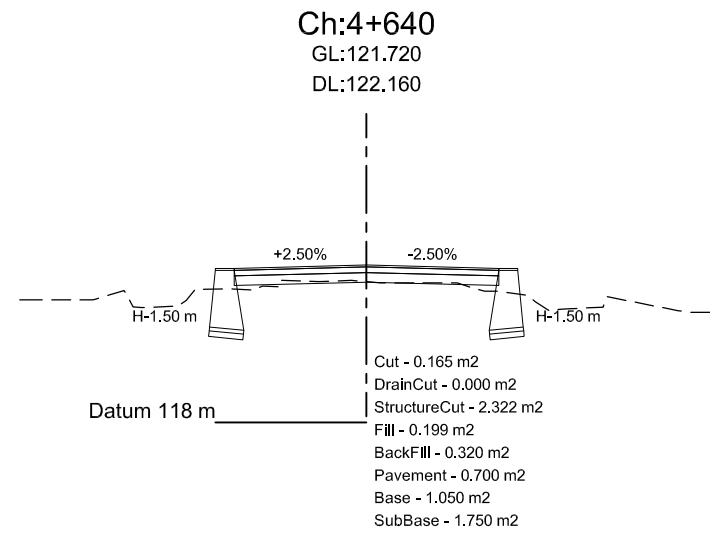

Department of Urban Development & Building
Construction (DUDBC)
Regional Urban Development Project (RUDP)
West Urban Corridor (WUC) Development Project
Babarmahal, Kathmandu, Nepal

Reviewed & Designed By :
DOHWA Engineering Co. Ltd.
in Association with
ERMIC (P.) Ltd., SILT Consultants (P.) Ltd., and
DIGICON (P.) Ltd.
Mid-Baneshwor, Kathmandu
Tel: 01-4589393

Consultant
Team Leader : YOO CHANGMIN
Reviewed By : YAGYA BAHADUR MALLA
Designed By : MANJU MUNANKARMI

Client
Approved By :
Checked By :

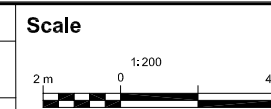

Cross-Section
BANCHAUKI-MAYADEVI PARK- MILDANDA
- BUDDHA CIRCUIT ROAD
CH 0+000 - 4+941.092 Km

REV : MAY 2024
DRG NO : DM/RD/CS/28
CHAINAGE : 4+600-4+760
SHEET NO : 28

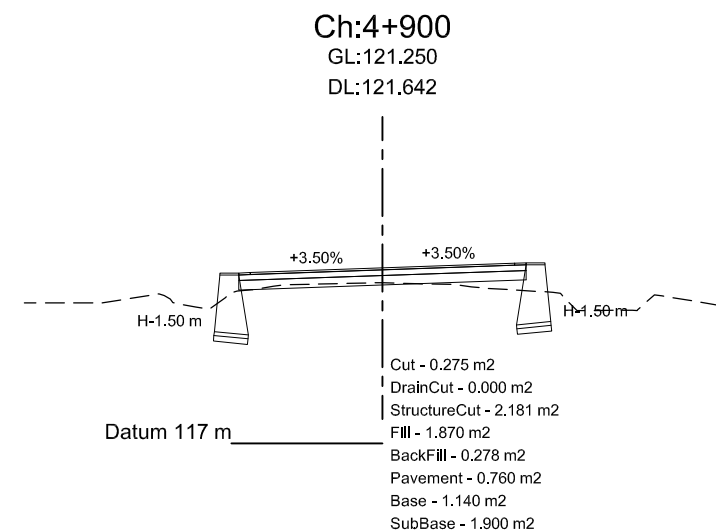
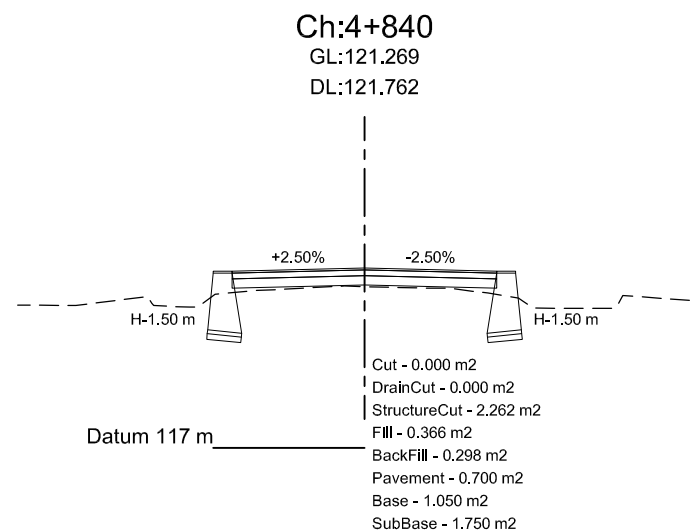
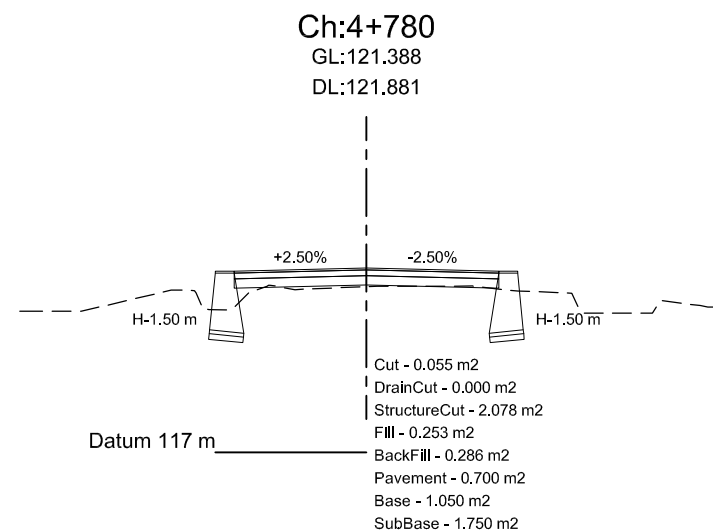
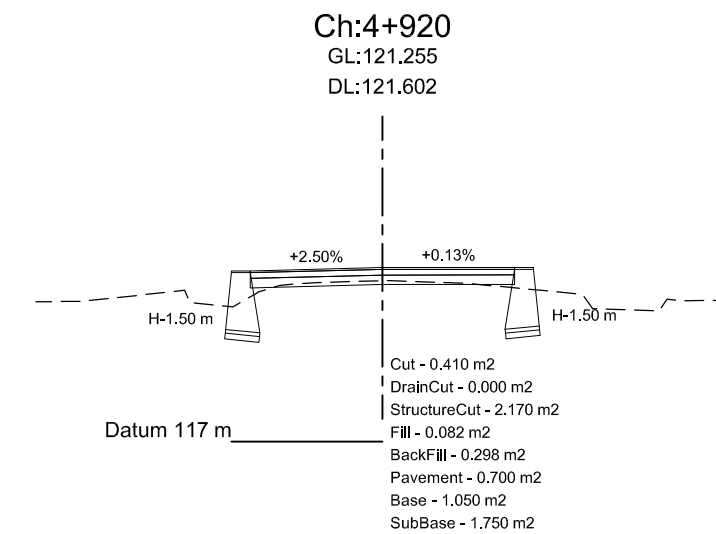
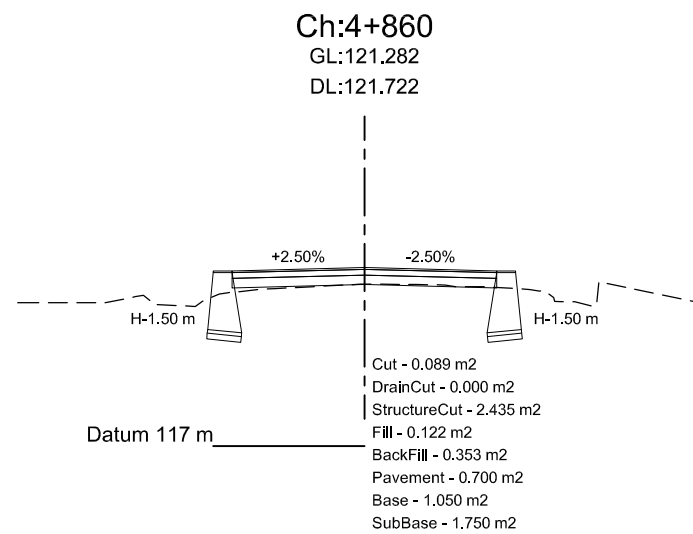
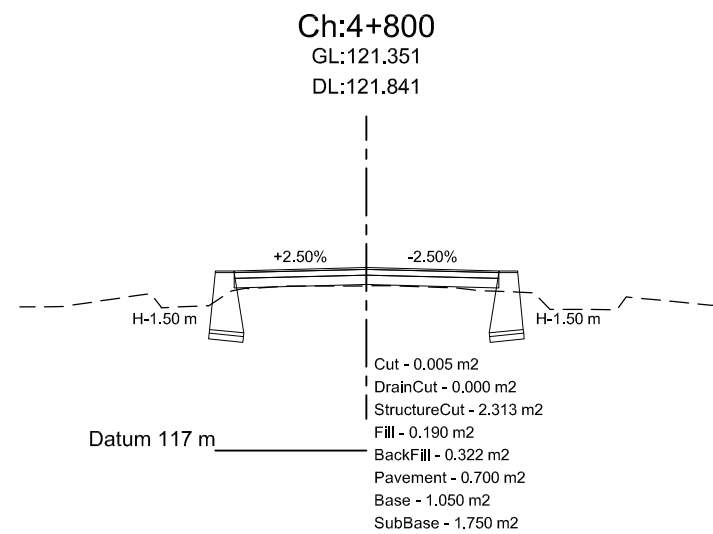
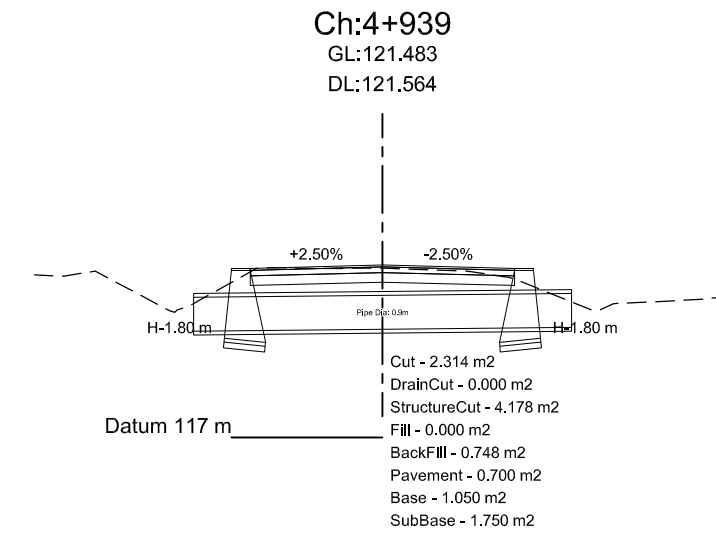
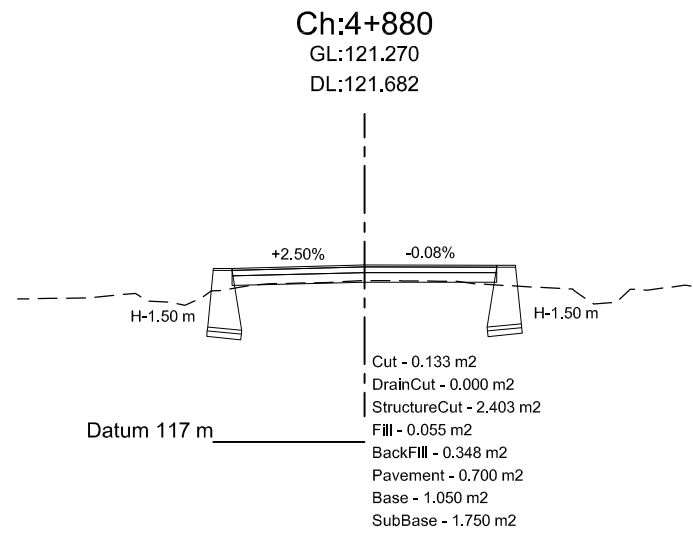
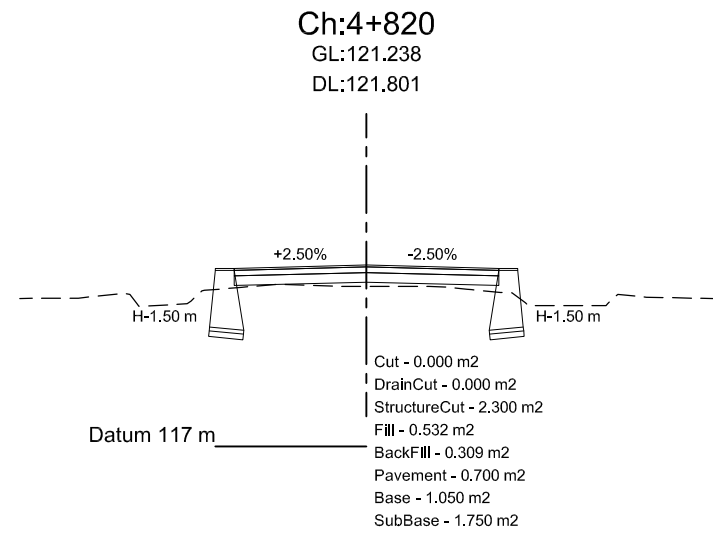

Department of Urban Development & Building
Construction (DUDBC)
Regional Urban Development Project (RUDP)
West Urban Corridor (WUC) Development Project
Babarmahal, Kathmandu, Nepal

Reviewed & Designed By :
DOHWA Engineering Co. Ltd.
in Association with
ERMIC (P.) Ltd., SILT Consultants (P.) Ltd., and
DIGICON (P.) Ltd.
Mid-Baneshwor, Kathmandu
Tel: 01-4589393

Consultant
Team Leader : YOO CHANGMIN
Reviewed By : YAGYA BAHADUR MALLA
Designed By : MANJU MUNANKARMI

Client
Approved By :
Checked By :

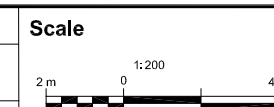

Cross-Section
BANCHAUKI-MAYADEVI PARK- MILDANDA
- BUDDHA CIRCUIT ROAD
CH 0+000 - 4+941.092 Km

REV : MAY 2024
DRG NO : DM/RD/CS/29
CHAINAGE : 4+780-4+939
SHEET NO : 29

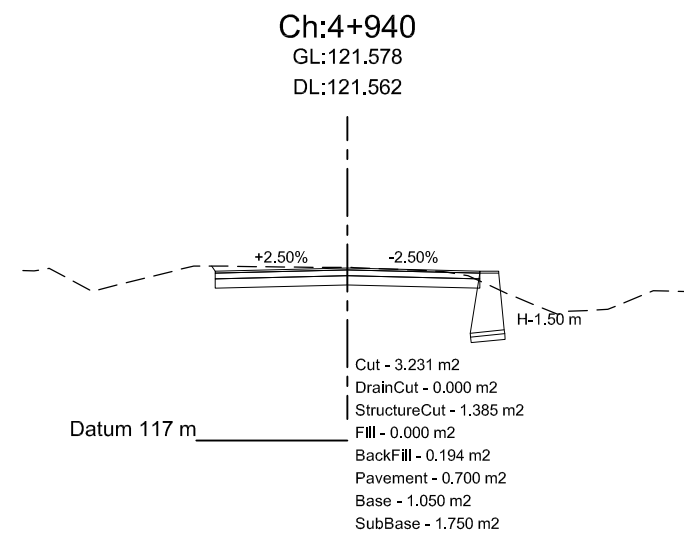
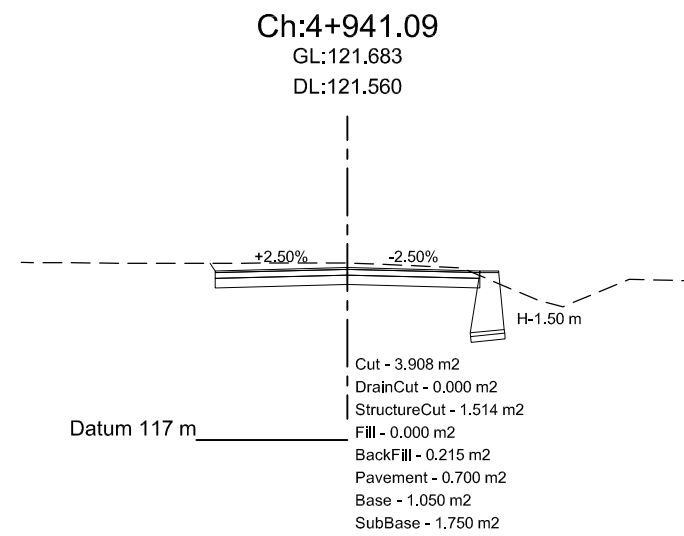

Department of Urban Development & Building
Construction (DUDBC)
Regional Urban Development Project (RUDP)
West Urban Corridor (WUC) Development Project
Babarmahal, Kathmandu, Nepal

Reviewed & Designed By :
DOHWA Engineering Co. Ltd.
in Association with
ERMIC (P.) Ltd., SILT Consultants (P.) Ltd., and
DIGICON (P.) Ltd.
Mid- Baneshwor, Kathmandu
Tel: 01-4589393

Consultant
Team Leader : YOO CHANGMIN
Reviewed By : YAGYA BAHADUR MALLA
Designed By : MANJU MUNANKARMI

Client
Approved By :
Checked By :

Scale

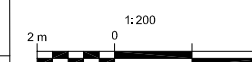

Cross-Section
BANCHAUKI-MAYADEVI PARK- MILDANDA
- BUDDHA CIRCUIT ROAD
CH 0+000 - 4+941.092 Km

REV : MAY 2024
DRG NO : DM/RD/CS/30
CHAINAGE : 4+940-4+941.09
SHEET NO : 30