

Department of Urban Development & Building Construction (DUDBC)
Regional Urban Development Project (RUDP)
West Urban Corridor (WUC) Development Project
Babarmahal, Kathmandu, Nepal

Reviewed & Designed By :
DOHWA Engineering Co. Ltd.
in Association with
ERMIC (P.) Ltd., SILT Consultants (P.) Ltd., and
DIGICON (P.) Ltd.
Mid-Baneshwor, Kathmandu
Tel: 01-4589393

Consultant
Team Leader : YOO CHANGMIN
Reviewed By : YAGYA BAHADUR MALLA
Designed By : MANJU MUNANKARMI

Client
Approved By :
Checked By :

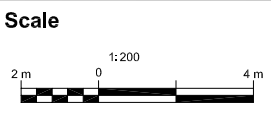

Cross-Section
BHALUHIPUL-MEDICAL COLLEGE-
BHATATOL-MUKHIYATOL-PIPARHIYA-
SINGHA-MUNICIPALITY
CH 0+000 - 7+503.82 Km

REV : MAY 2024
DRG NO : DM/RD/CS/1
CHAINAGE : 0+000-0+140
SHEET NO : 1

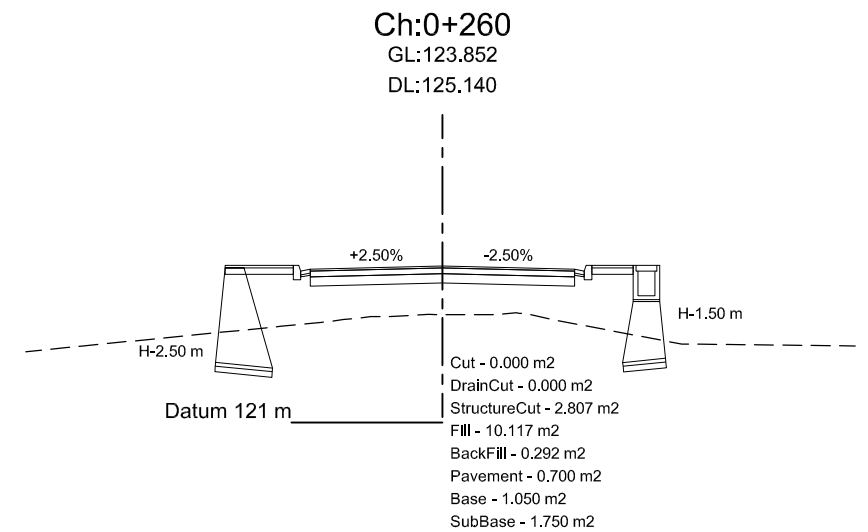
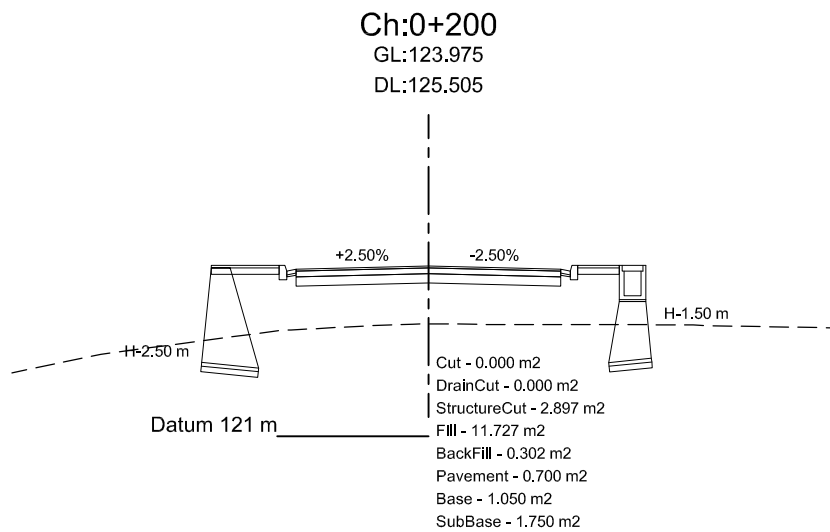
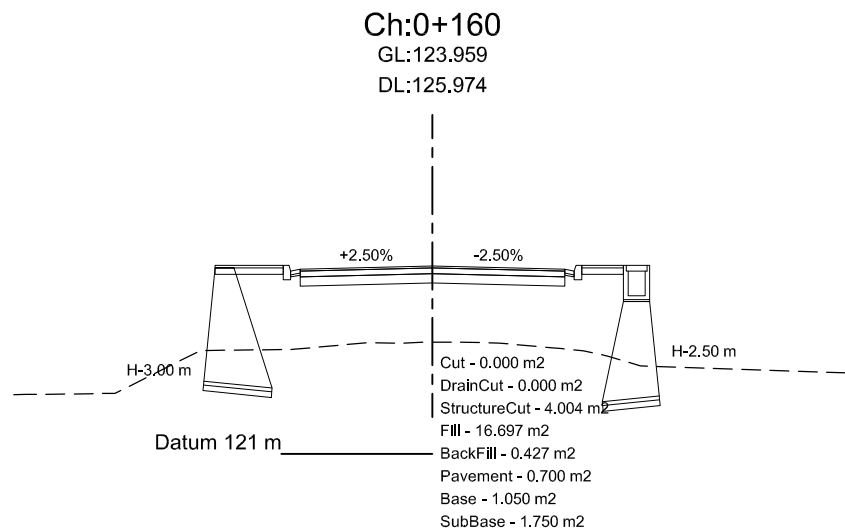
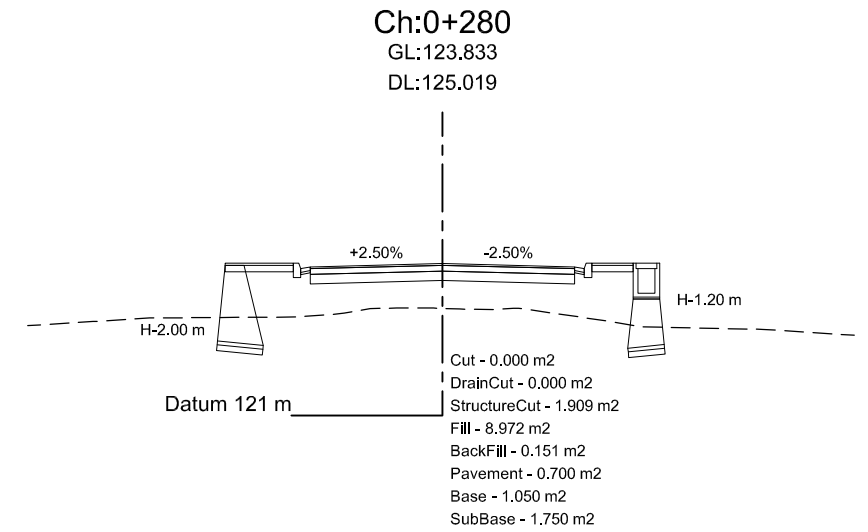
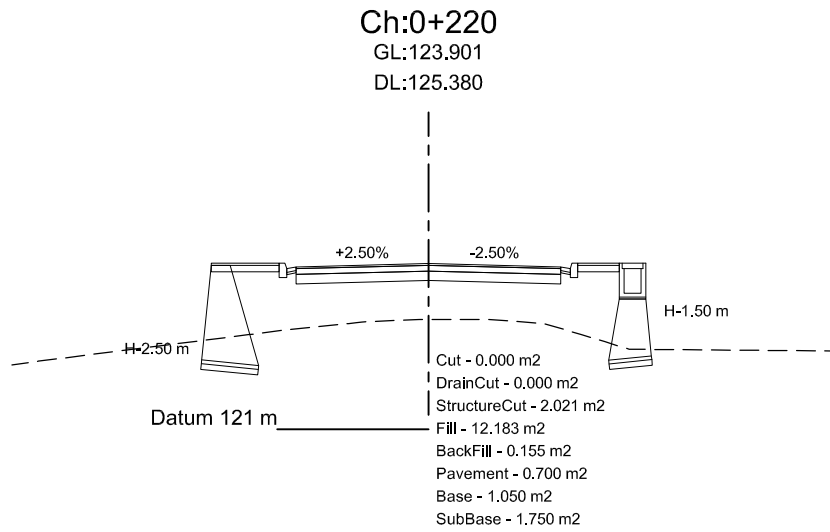
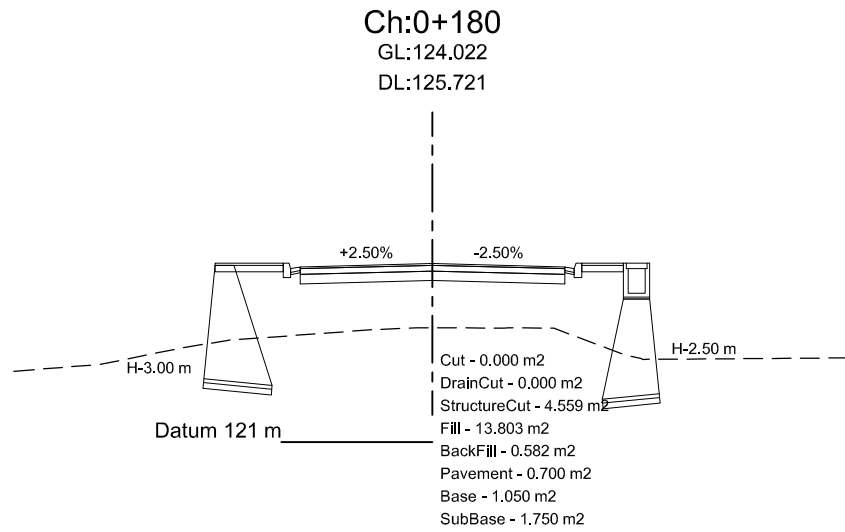
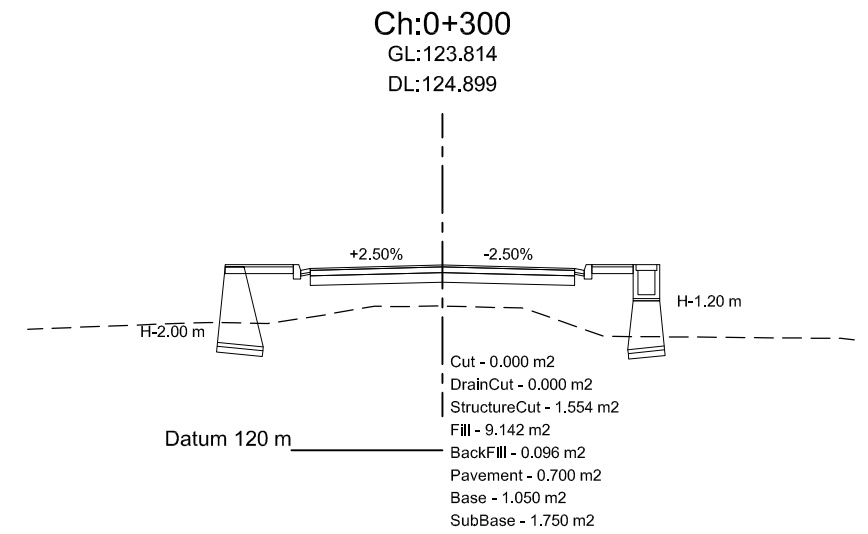
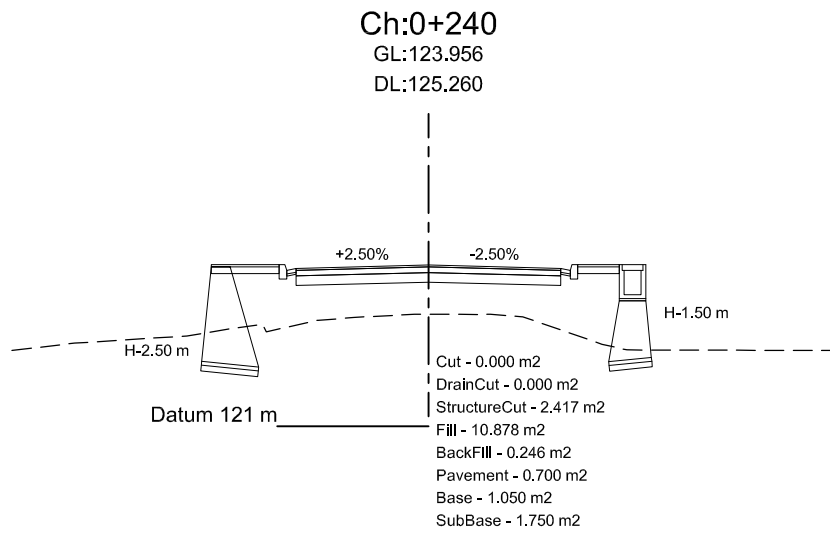
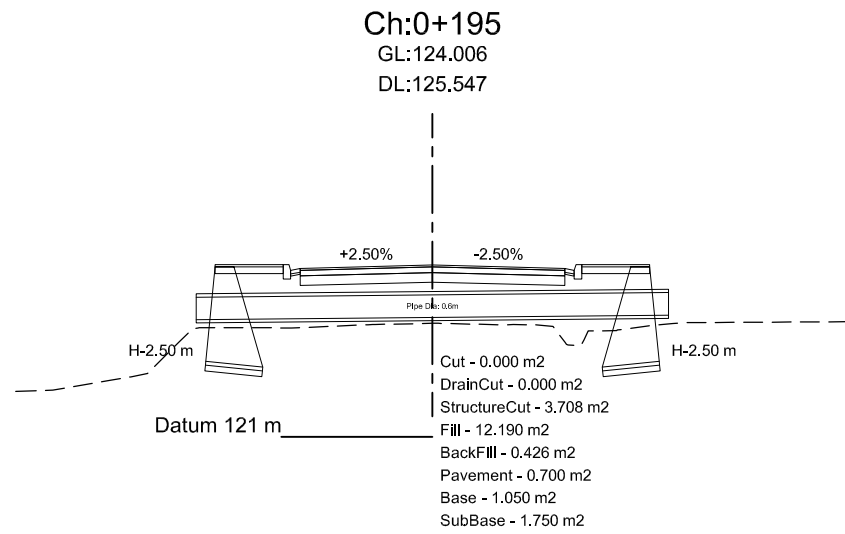

Department of Urban Development & Building
Construction (DUDBC)
Regional Urban Development Project (RUDP)
West Urban Corridor (WUC) Development Project
Babarmahal, Kathmandu, Nepal

Reviewed & Designed By :
DOHWA Engineering Co. Ltd.
in Association with
ERMIC (P.) Ltd., SILT Consultants (P.) Ltd., and
DIGICON (P.) Ltd.
Mid- Baneshwor, Kathmandu
Tel: 01- 4589393

Consultant
Team Leader : YOO CHANGMIN
Reviewed By : YAGYA BAHADUR MALLA
Designed By : MANJU MUNANKARMI

Client
Approved By :
Checked By :

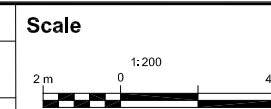

Cross-Section
BHALUHIPUL-MEDICAL COLLEGE-
BHATATOL-MUKHIYATOL-PIPARHIYA-
SINGHA-MUNICIPALITY
CH 0+000 - 7+503.82 Km

REV : MAY 2024
DRG NO : DM/RD/CS/2
CHAINAGE : 0+160-0+300
SHEET NO : 2

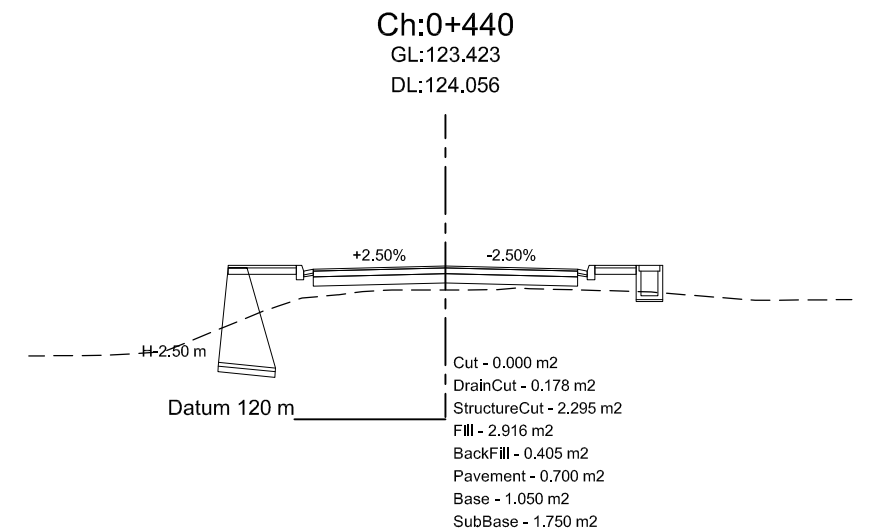
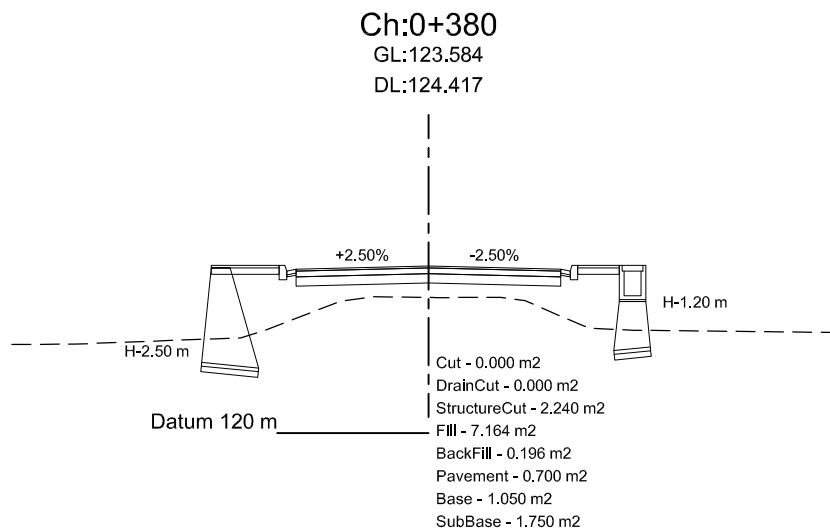
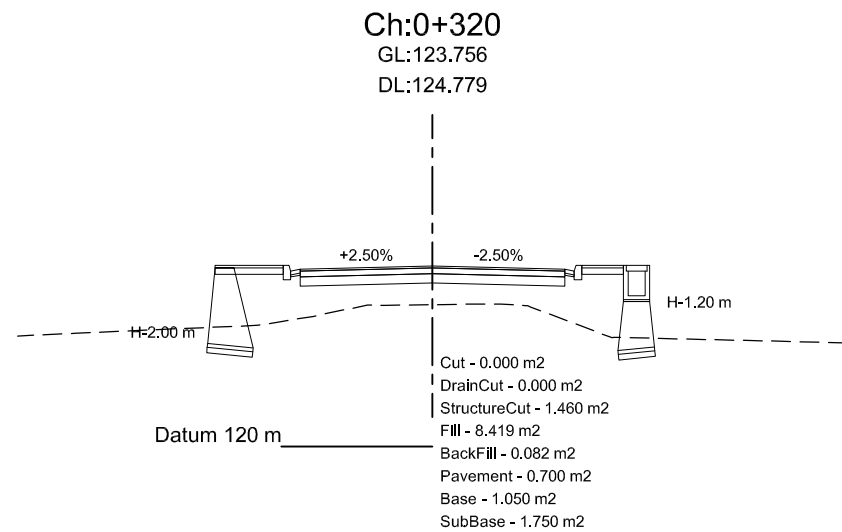
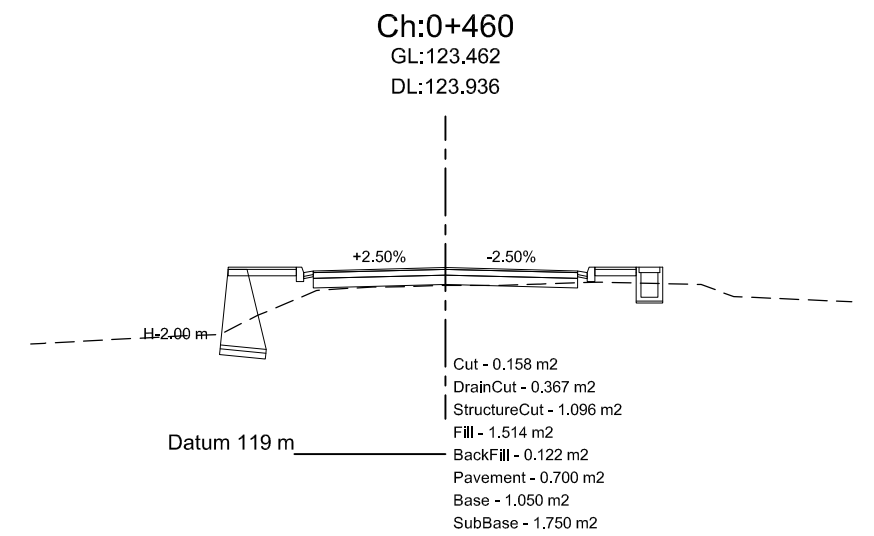
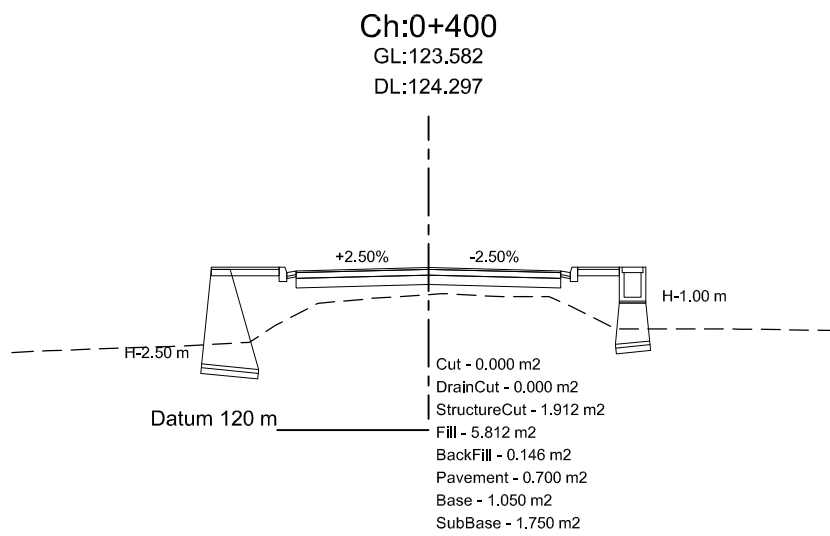
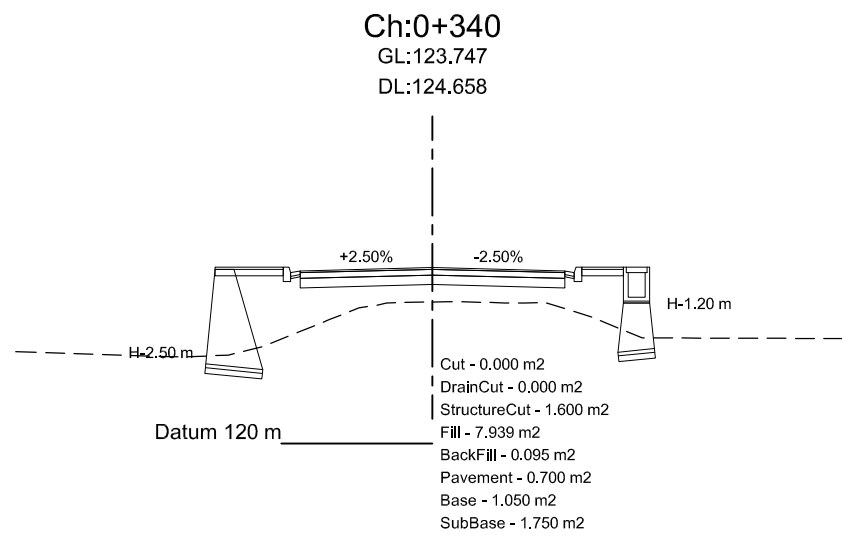
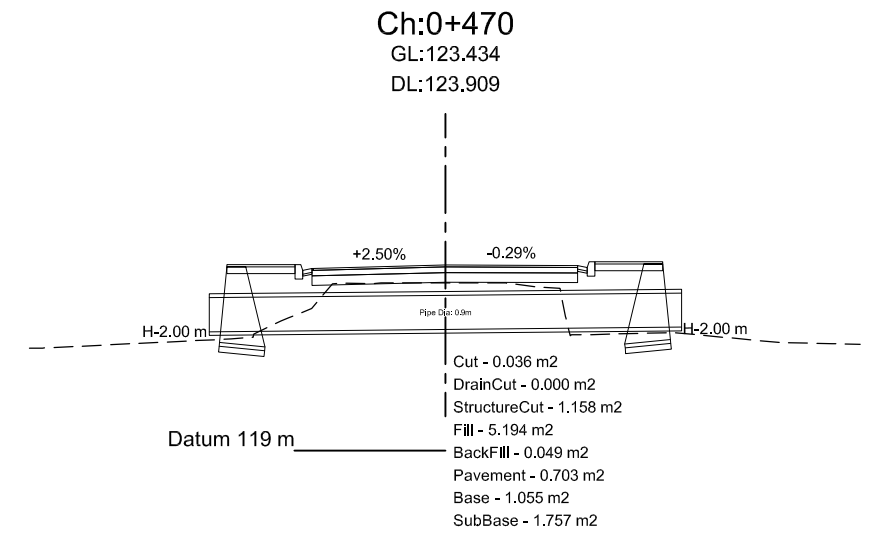
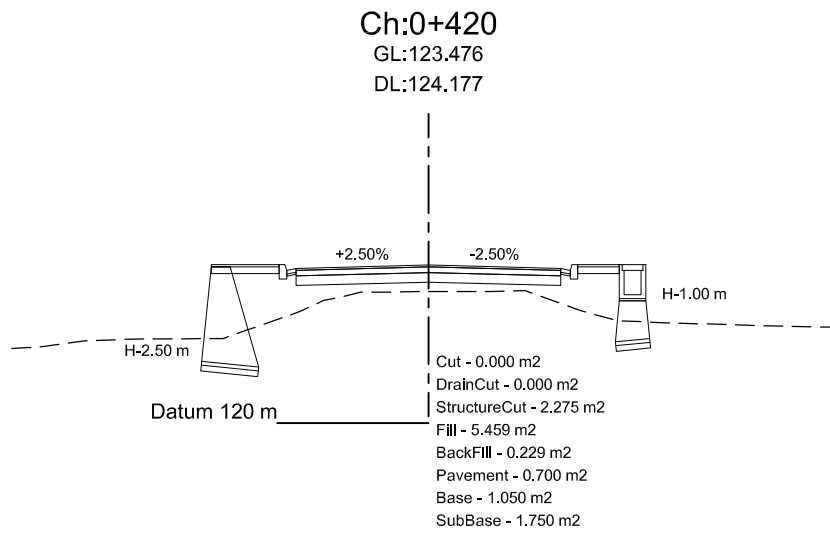
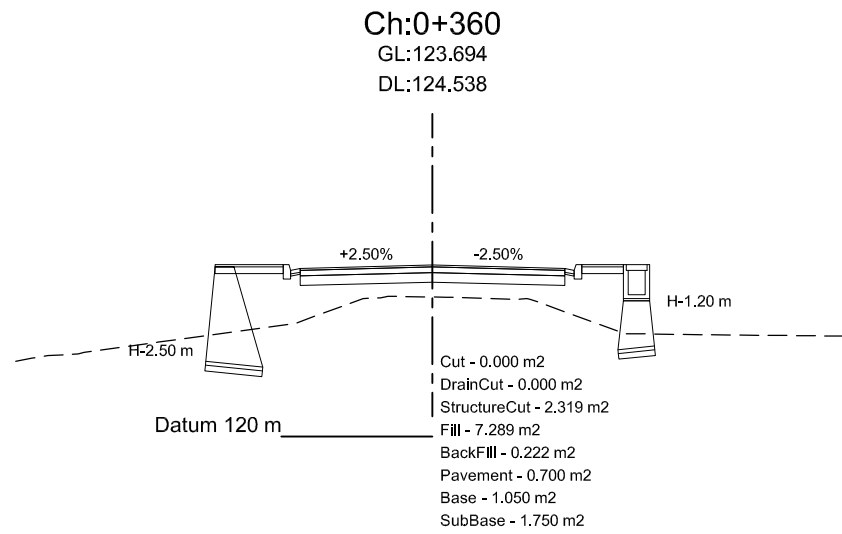

Department of Urban Development & Building
Construction (DUDBC)
Regional Urban Development Project (RUDP)
West Urban Corridor (WUC) Development Project
Babarmahal, Kathmandu, Nepal

Reviewed & Designed By :
DOHWA Engineering Co. Ltd.
in Association with
ERMIC (P.) Ltd., SILT Consultants (P.) Ltd., and
DIGICON (P.) Ltd.
Mid- Baneshwor, Kathmandu
Tel: 01- 4589393

Consultant
Team Leader : YOO CHANGMIN
Reviewed By : YAGYA BAHADUR MALLA
Designed By : MANJU MUNANKARMI

Client
Approved By :
Checked By :

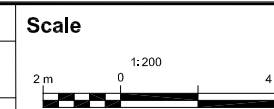

Cross-Section
BHALUHIPUL-MEDICAL COLLEGE-
BHATATOL-MUKHIYATOL-PIPARHIYA-
SINGHA-MUNICIPALITY
CH 0+000 - 7+503.82 Km

REV : MAY 2024
DRG NO : DM/RD/CS/3
CHAINAGE : 0+320-0+470
SHEET NO : 3

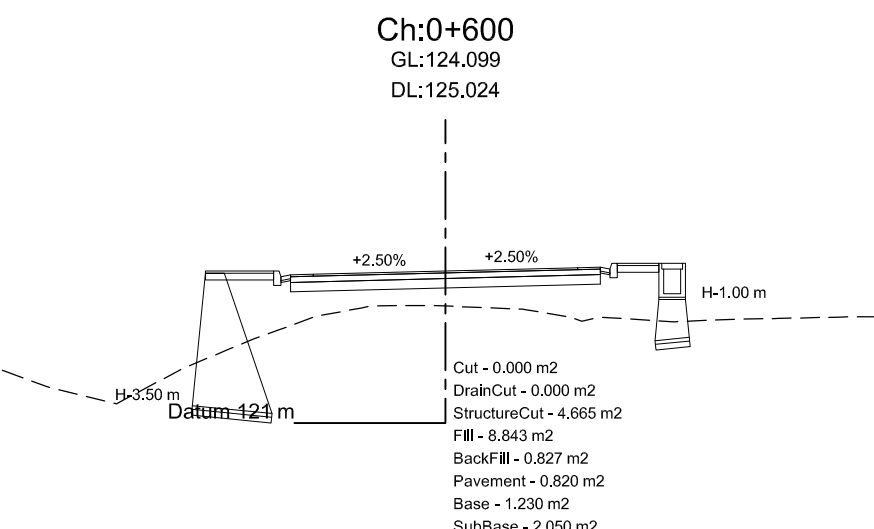
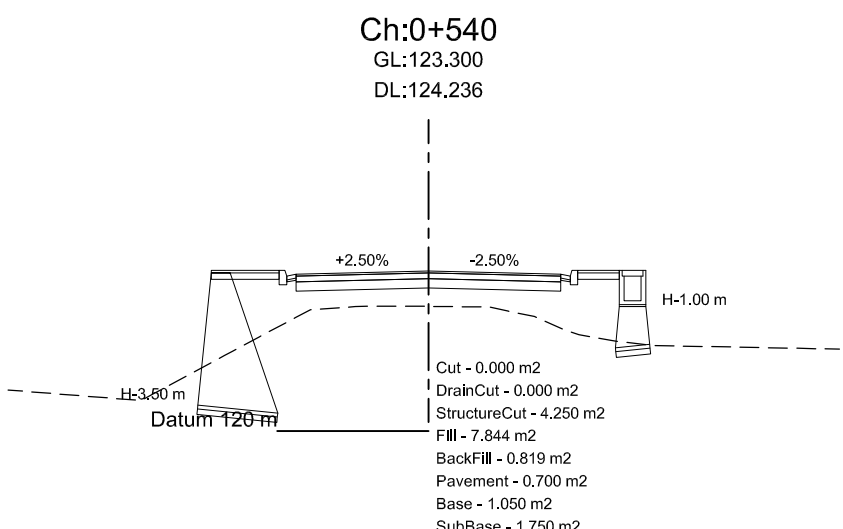
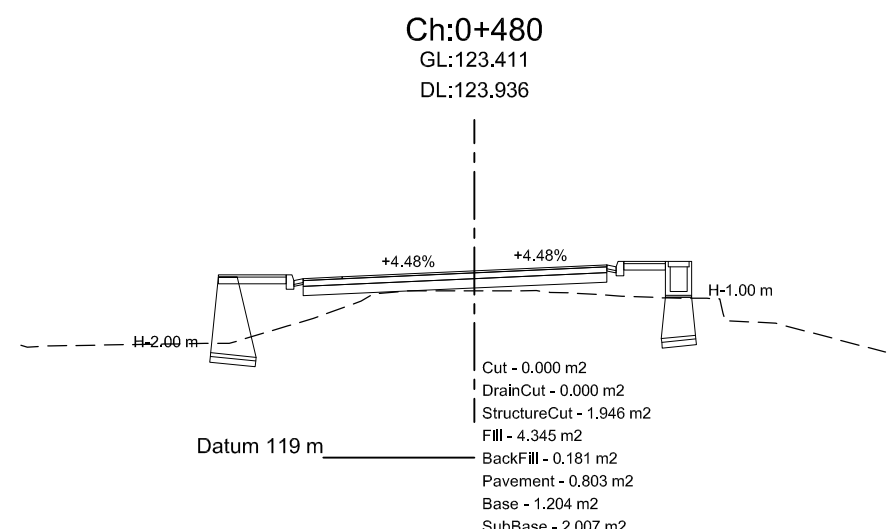
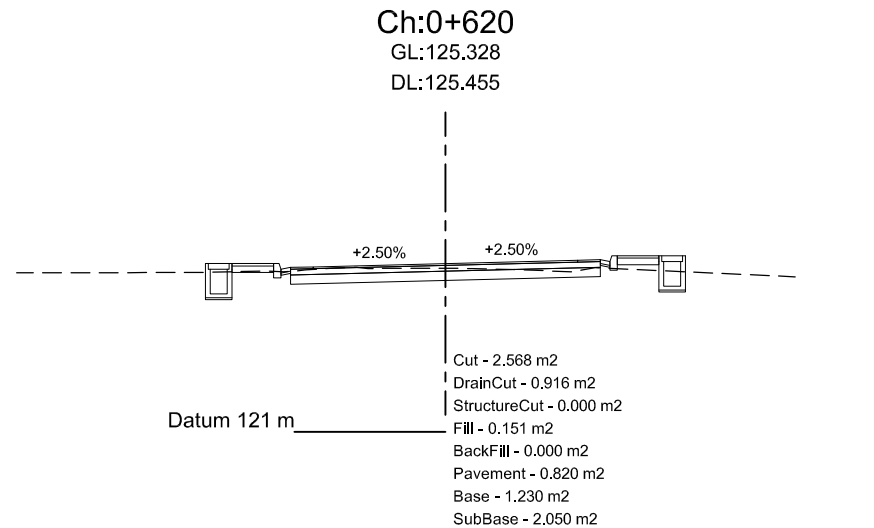
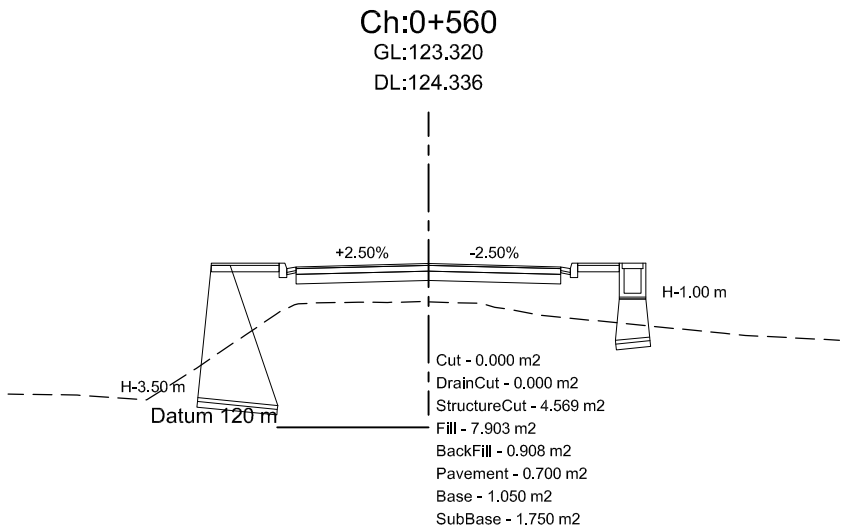
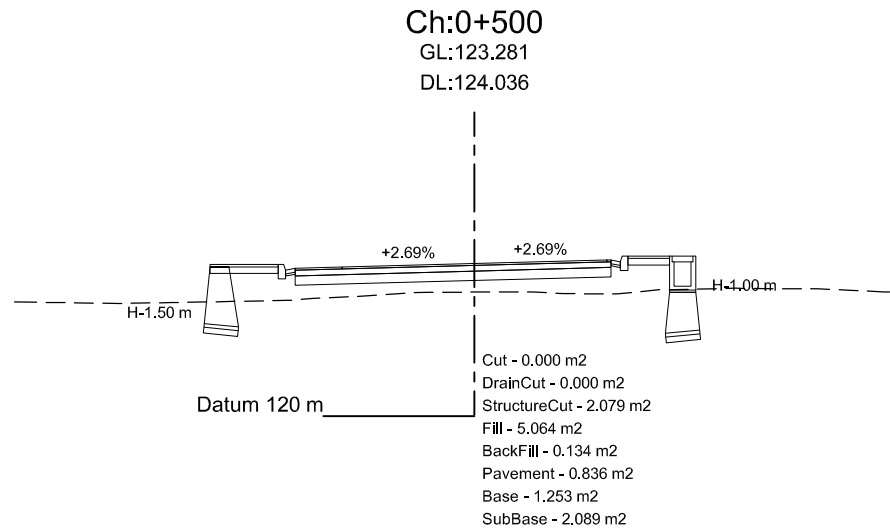
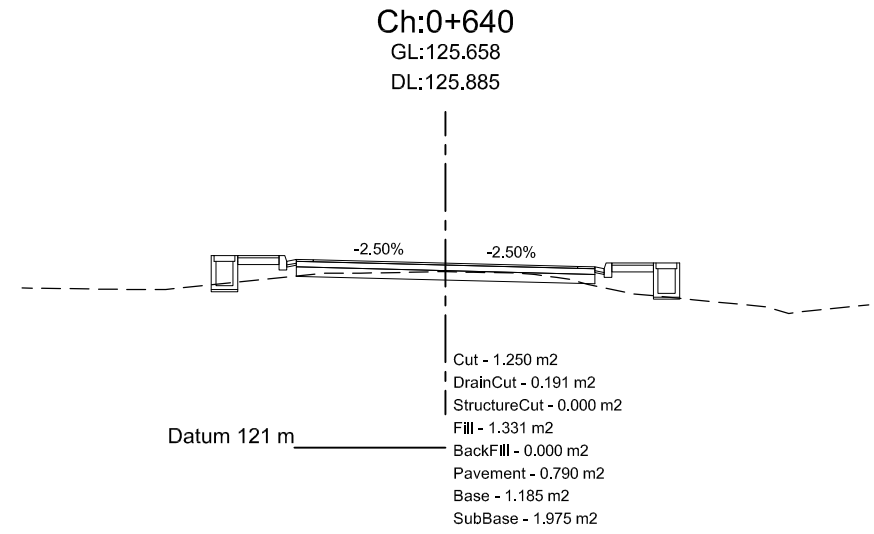
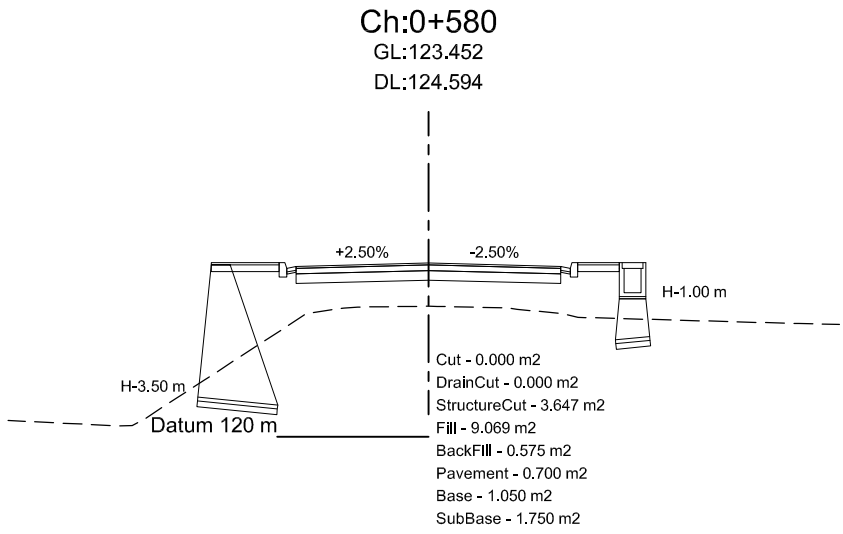
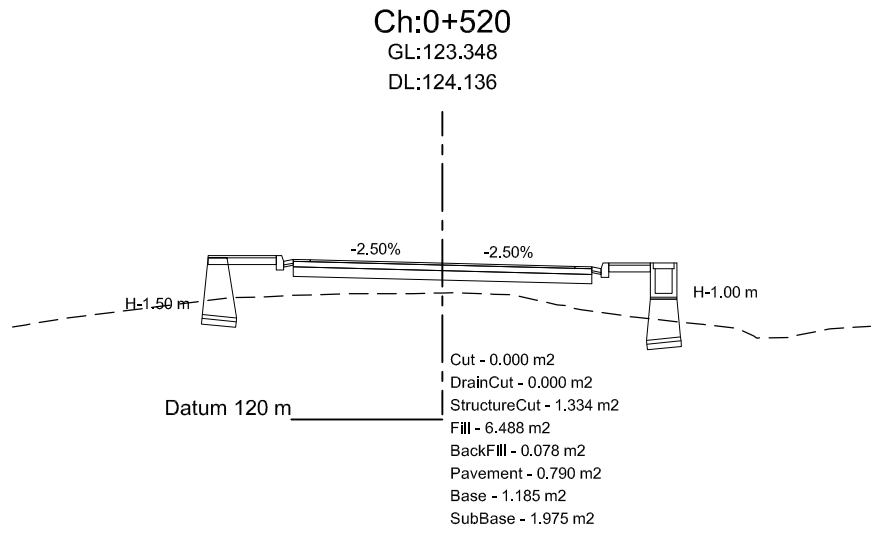

Department of Urban Development & Building Construction (DUDBC)
Regional Urban Development Project (RUDP)
West Urban Corridor (WUC) Development Project
Babarmahal, Kathmandu, Nepal

Reviewed & Designed By :
DOHWA Engineering Co. Ltd.
in Association with
ERMIC (P.) Ltd., SILT Consultants (P.) Ltd., and
DIGICON (P.) Ltd.
Mid- Baneshwor, Kathmandu
Tel: 01- 4589393

Consultant
Team Leader : YOO CHANGMIN
Reviewed By : YAGYA BAHADUR MALLA
Designed By : MANJU MUNANKARMI

Client
Approved By :
Checked By :

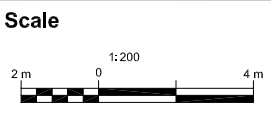

Cross-Section
BHALUHIPUL-MEDICAL COLLEGE-
BHATATOL-MUKHIYATOL-PIPARHIYA-
SINGHA-MUNICIPALITY
CH 0+000 - 7+503.82 Km

REV : MAY 2024
DRG NO : DM/RD/CS/4
CHAINAGE : 0+480-0+640
SHEET NO : 4

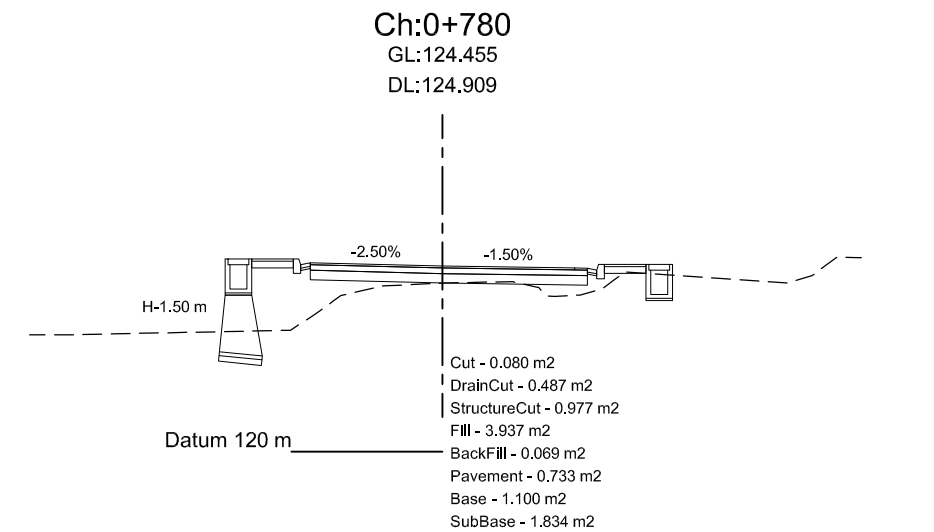
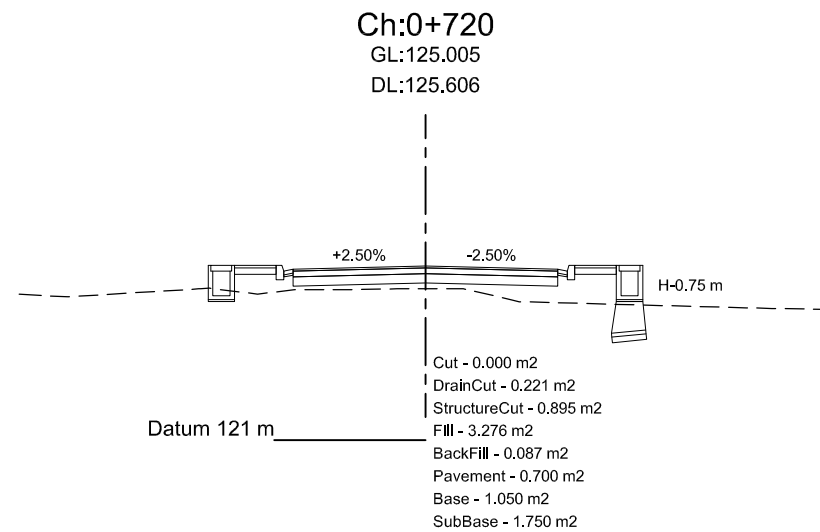
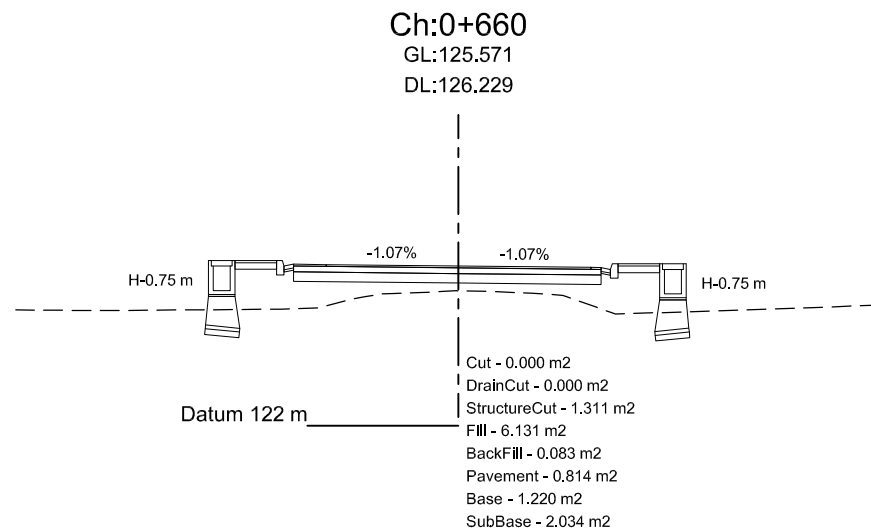
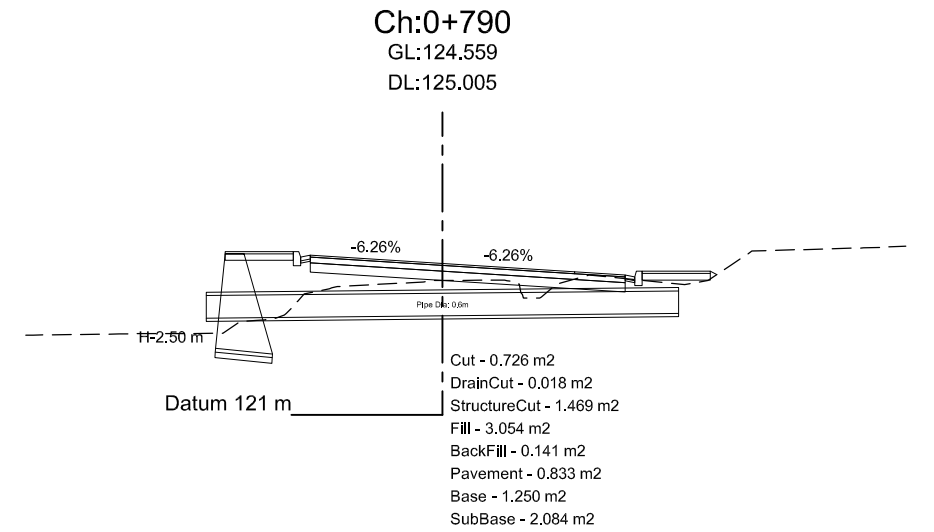
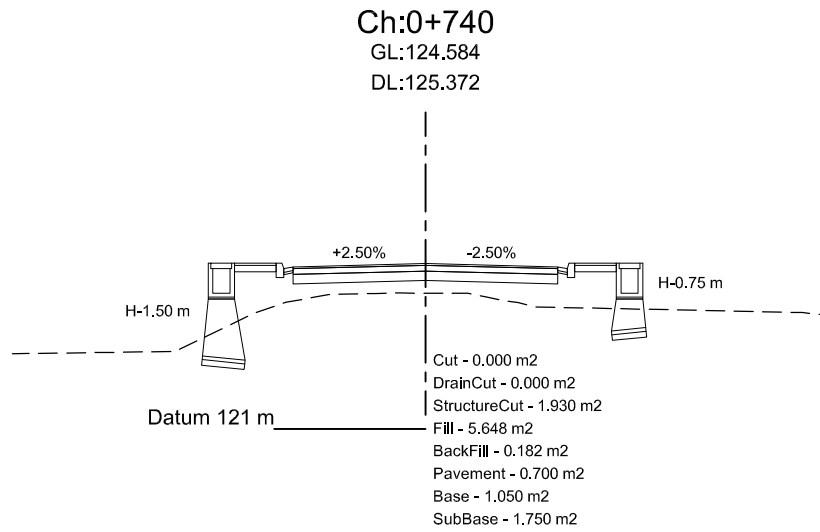
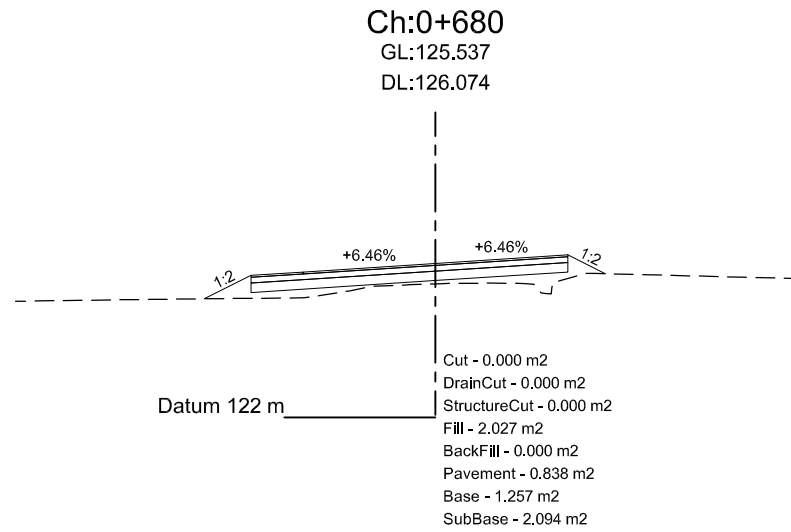
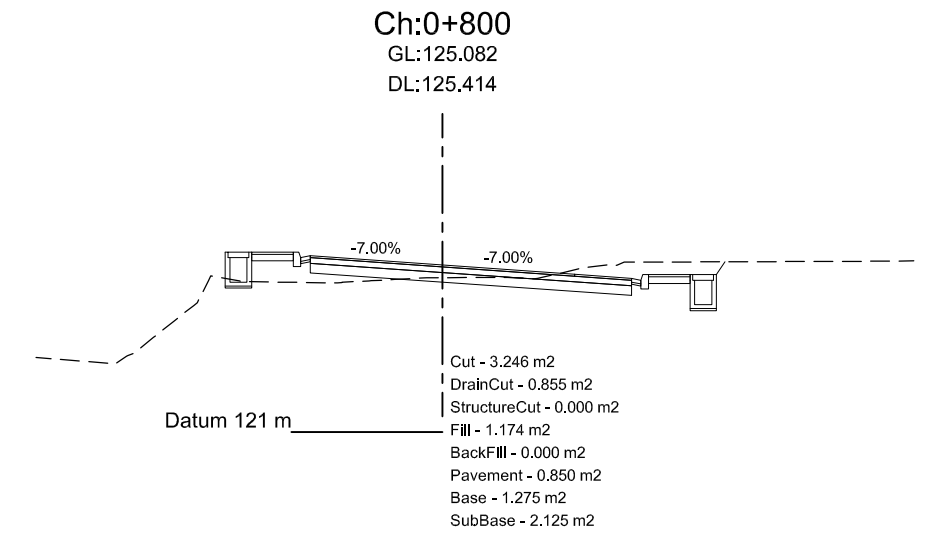
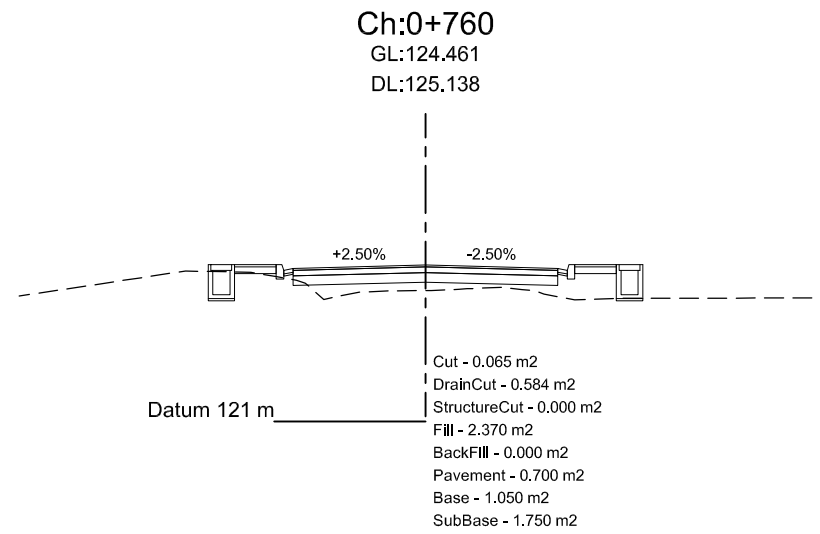
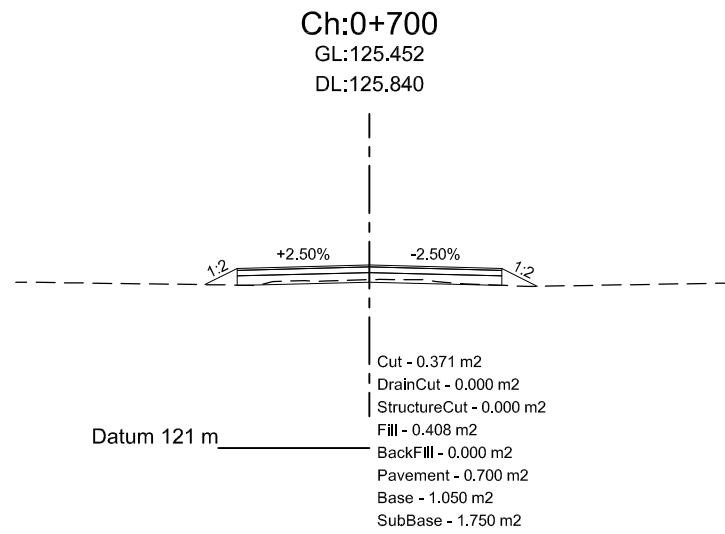

Department of Urban Development & Building Construction (DUDBC)
Regional Urban Development Project (RUDP)
West Urban Corridor (WUC) Development Project
Babarmahal, Kathmandu, Nepal

Reviewed & Designed By :
DOHWA Engineering Co. Ltd.
in Association with
ERMIC (P.) Ltd., SILT Consultants (P.) Ltd., and
DIGICON (P.) Ltd.
Mid-Baneshwor, Kathmandu
Tel: 01-4589393

Consultant
Team Leader : YOO CHANGMIN
Reviewed By : YAGYA BAHADUR MALLA
Designed By : MANJU MUNANKARMI

Client
Approved By :
Checked By :

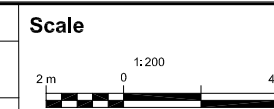

Cross-Section
BHALUHIPUL-MEDICAL COLLEGE-
BHATATOL-MUKHIYATOL-PIPARHIYA-
SINGHA-MUNICIPALITY
CH 0+000 - 7+503.82 Km

REV : MAY 2024
DRG NO : DM/RD/CS/5
CHAINAGE : 0+660-0+800
SHEET NO : 5

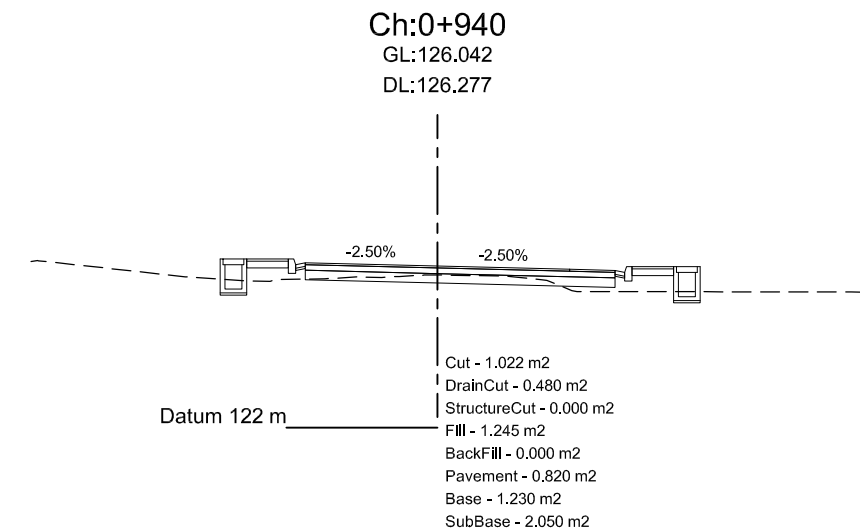
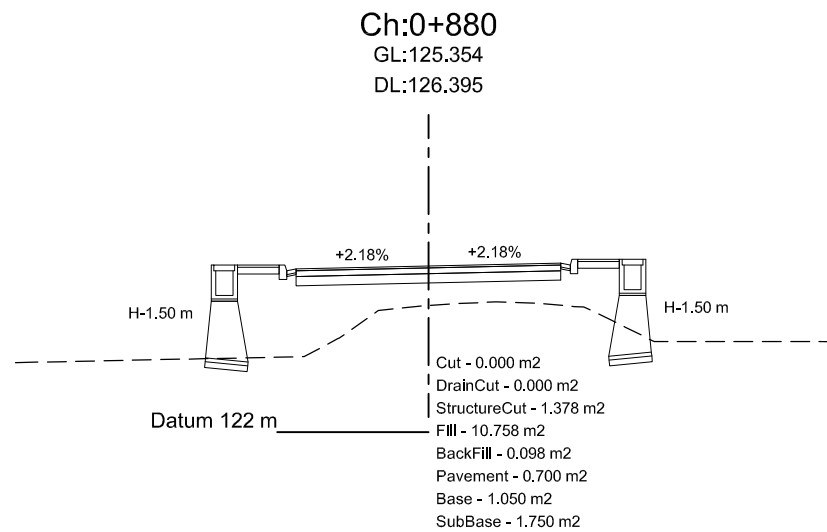
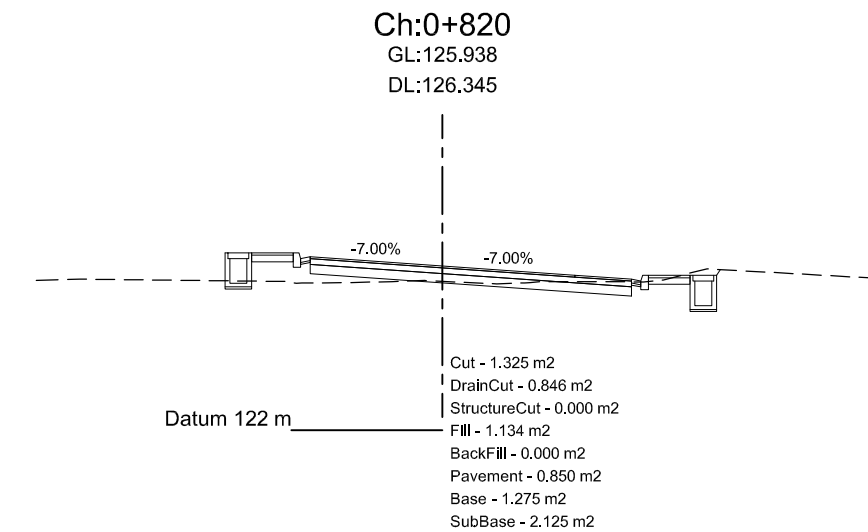
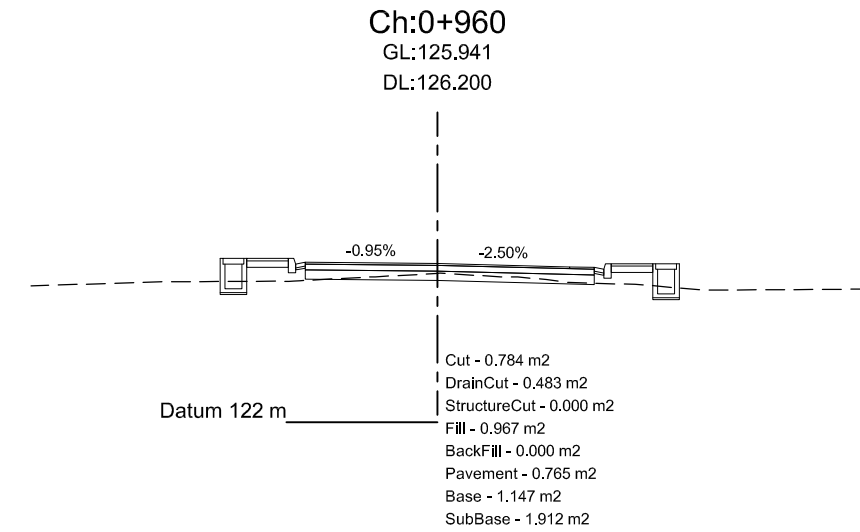
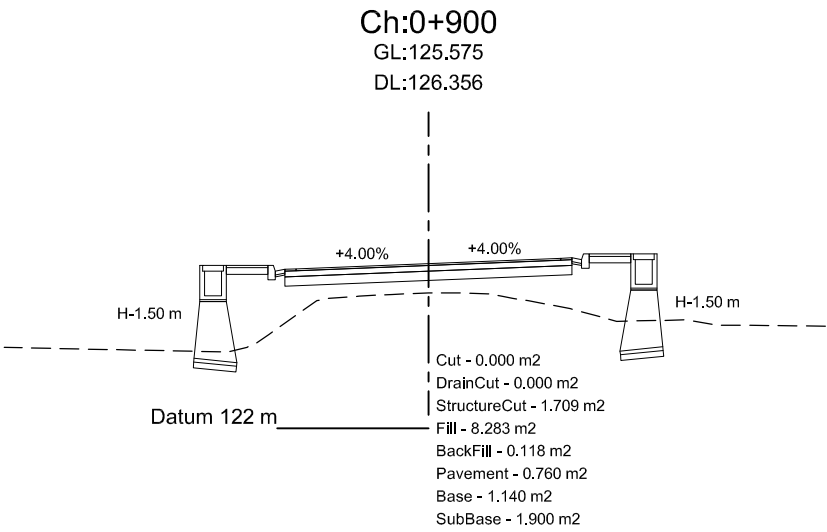
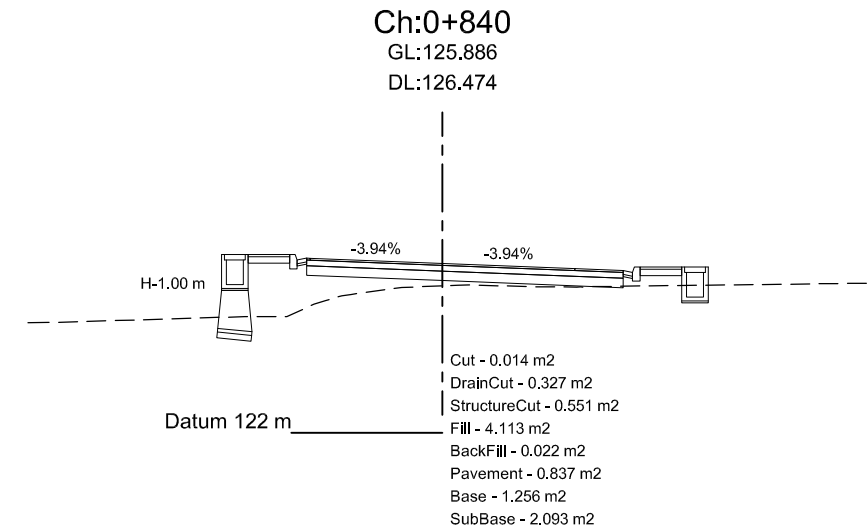
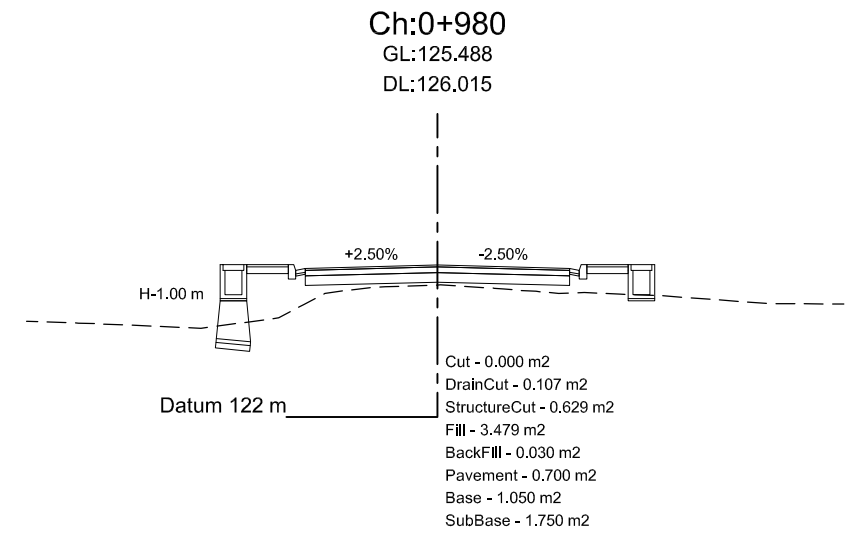
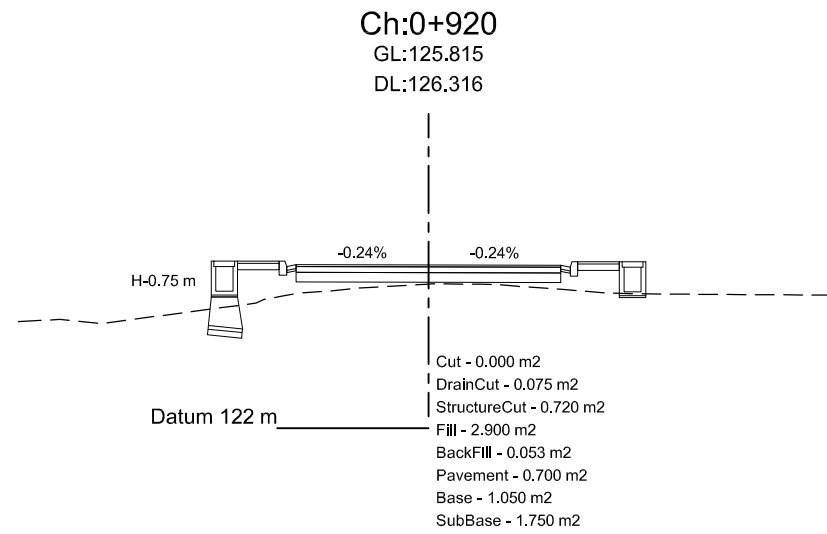
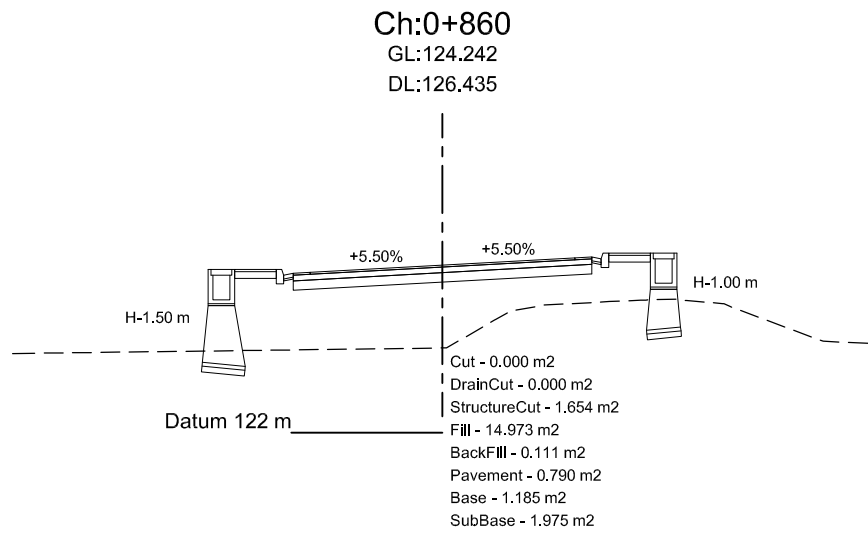

Department of Urban Development & Building
Construction (DUDBC)
Regional Urban Development Project (RUDP)
West Urban Corridor (WUC) Development Project
Babarmahal, Kathmandu, Nepal

Reviewed & Designed By :
DOHWA Engineering Co. Ltd.
in Association with
ERMIC (P.) Ltd., SILT Consultants (P.) Ltd., and
DIGICON (P.) Ltd.
Mid- Baneshwor, Kathmandu
Tel: 01- 4589393

Consultant
Team Leader : YOO CHANGMIN
Reviewed By : YAGYA BAHADUR MALLA
Designed By : MANJU MUNANKARMI

Client
Approved By :
Checked By :

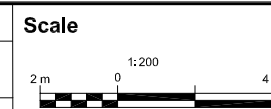

Cross-Section
BHALUHIPUL-MEDICAL COLLEGE-
BHATATOL-MUKHIYATOL-PIPARHIYA-
SINGHA-MUNICIPALITY
CH 0+000 - 7+503.82 Km

REV : MAY 2024
DRG NO : DM/RD/CS/6
CHAINAGE : 0+820-0+980
SHEET NO : 6

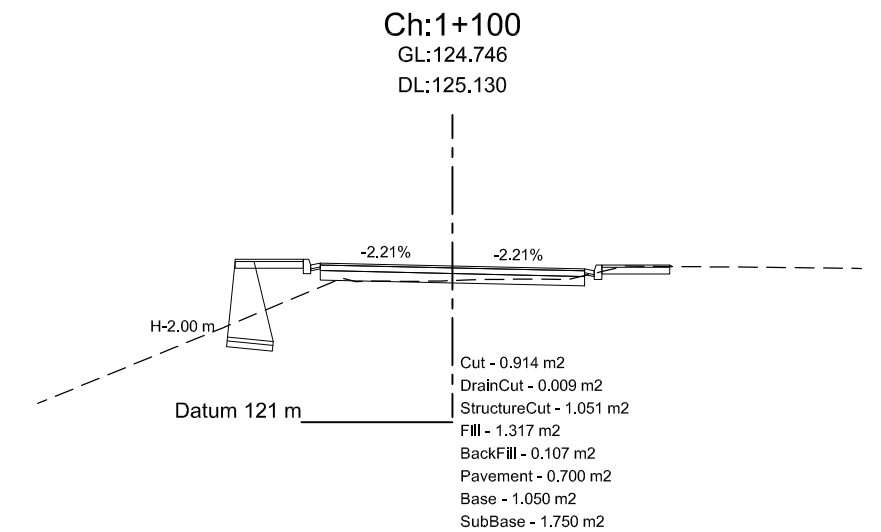
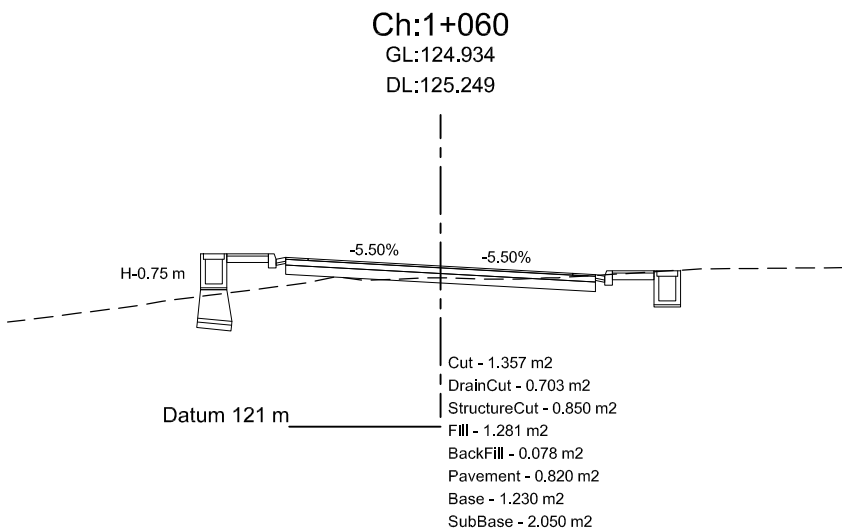
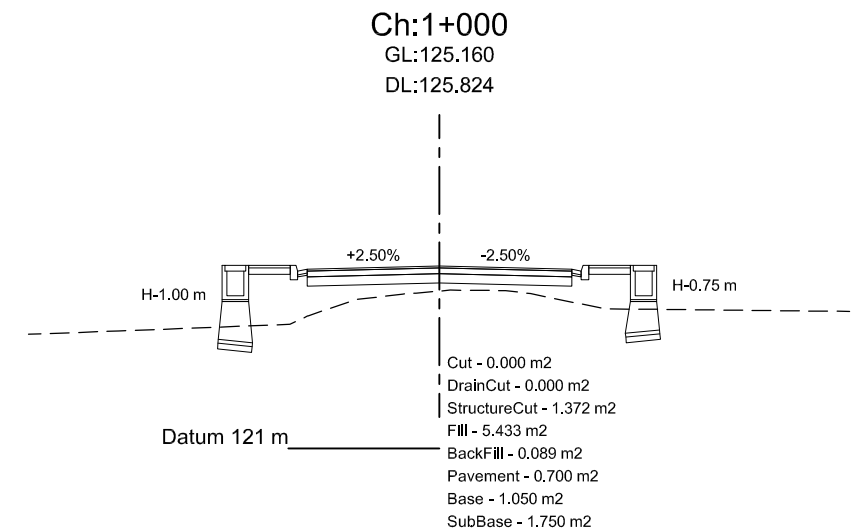
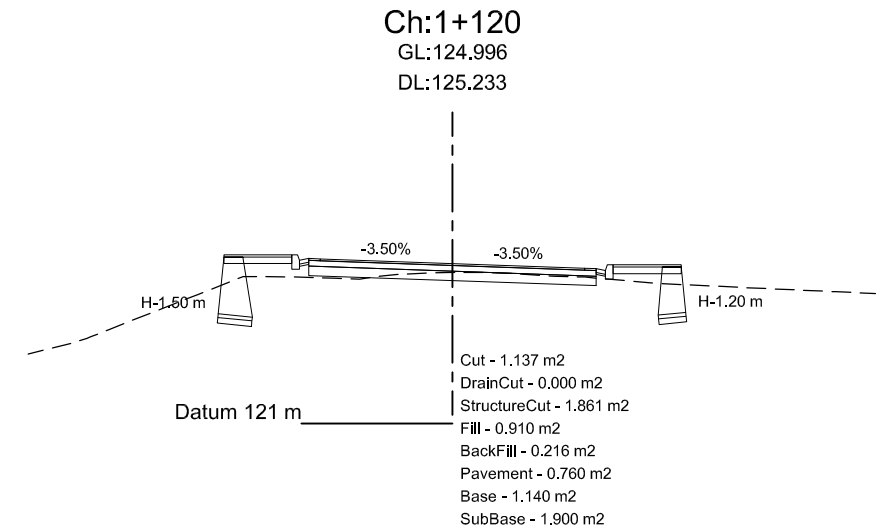
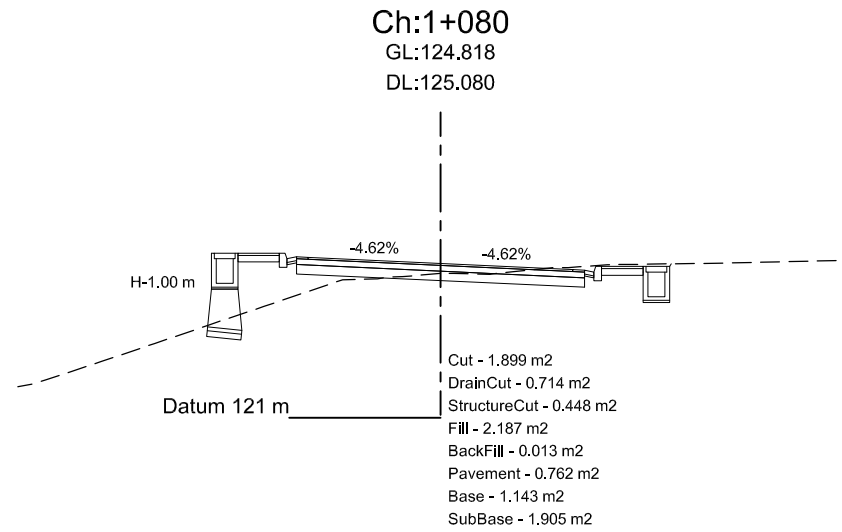
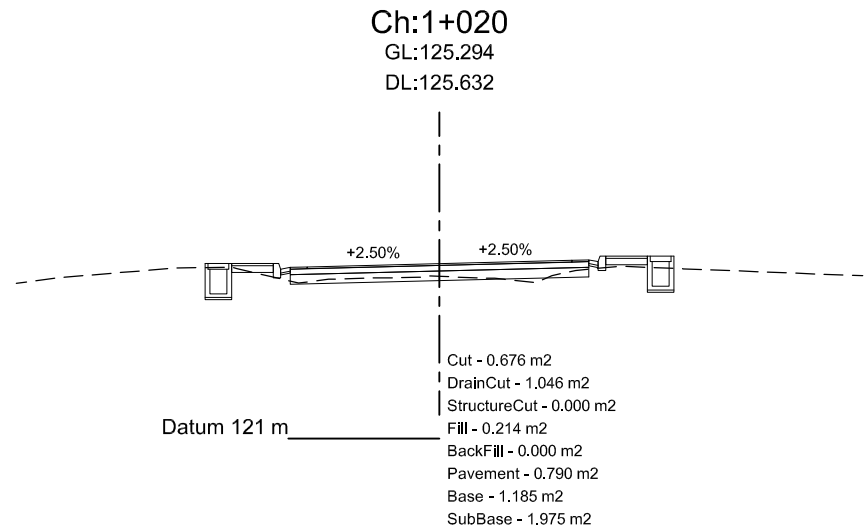
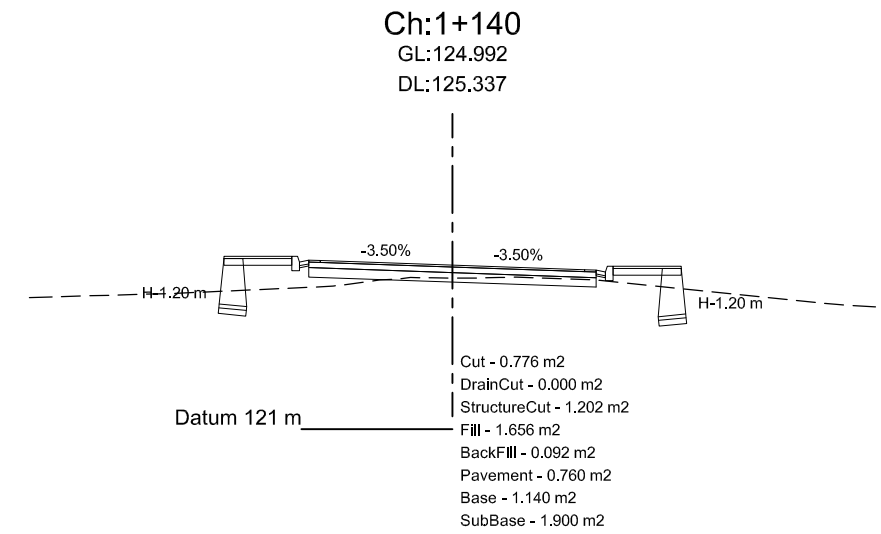
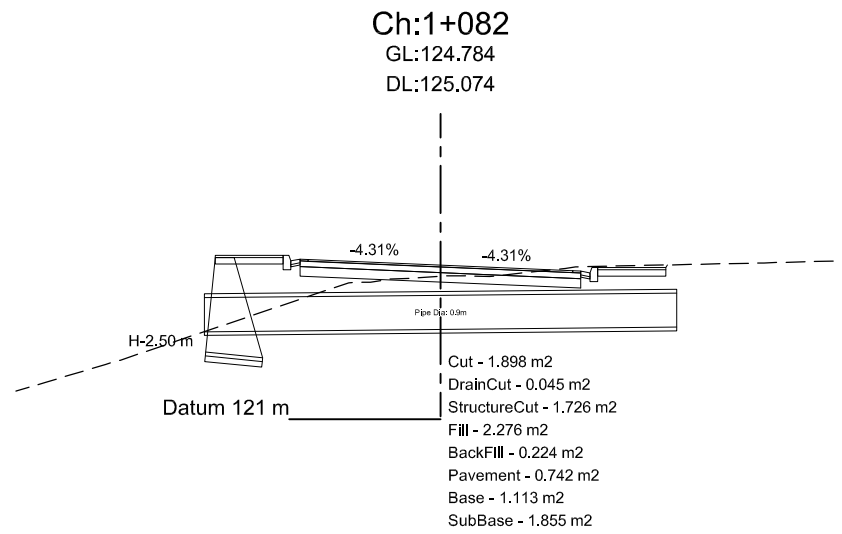
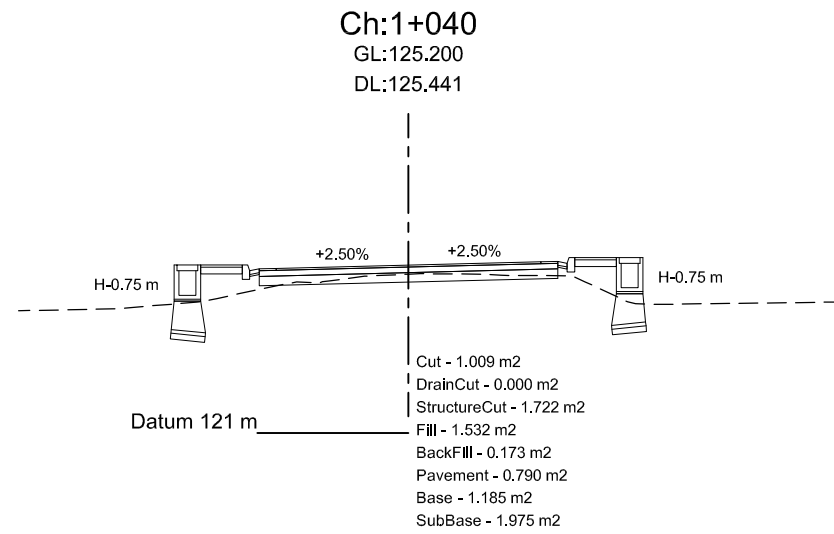

Department of Urban Development & Building
Construction (DUDBC)
Regional Urban Development Project (RUDP)
West Urban Corridor (WUC) Development Project
Babarmahal, Kathmandu, Nepal

Reviewed & Designed By :
DOHWA Engineering Co. Ltd.
in Association with
ERMIC (P.) Ltd., SILT Consultants (P.) Ltd., and
DIGICON (P.) Ltd.
Mid-Baneshwor, Kathmandu
Tel: 01-4589393

Consultant
Team Leader : YOO CHANGMIN
Reviewed By : YAGYA BAHADUR MALLA
Designed By : MANJU MUNANKARMI

Client
Approved By :
Checked By :

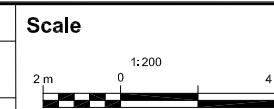

Cross-Section
BHALUHIPUL-MEDICAL COLLEGE-
BHATATOL-MUKHIYATOL-PIPARHIYA-
SINGHA-MUNICIPALITY
CH 0+000 - 7+503.82 Km

REV : MAY 2024
DRG NO : DM/RD/CS/7
CHAINAGE : 1+000-1+140
SHEET NO : 7

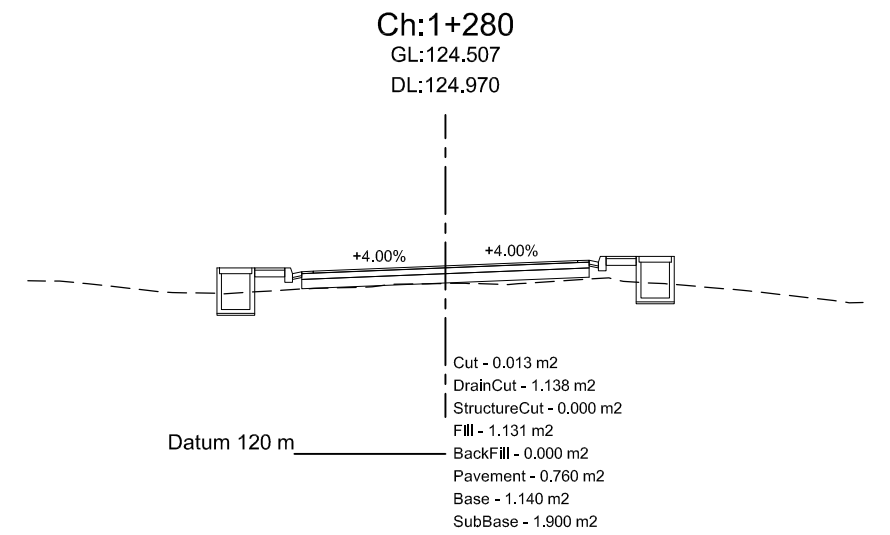
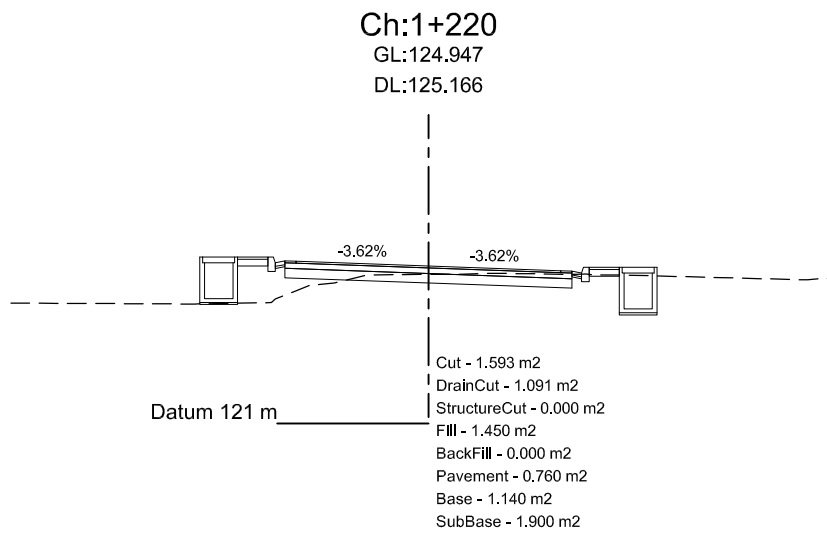
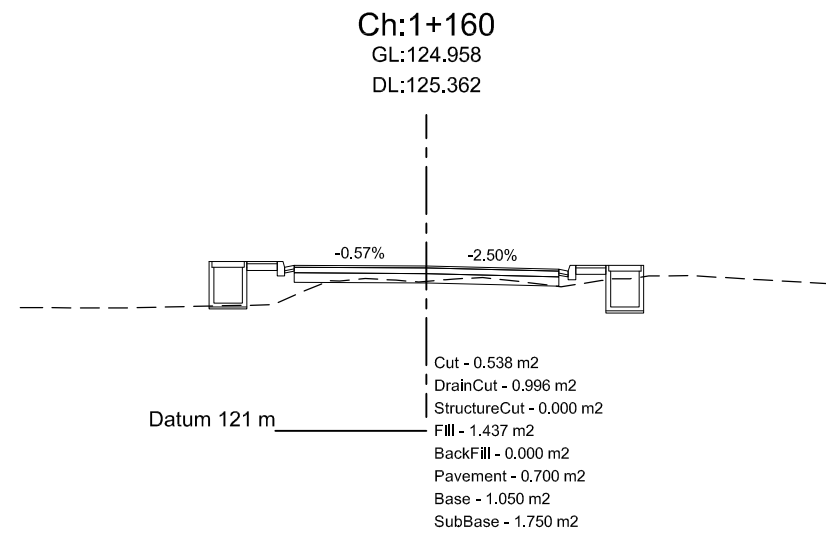
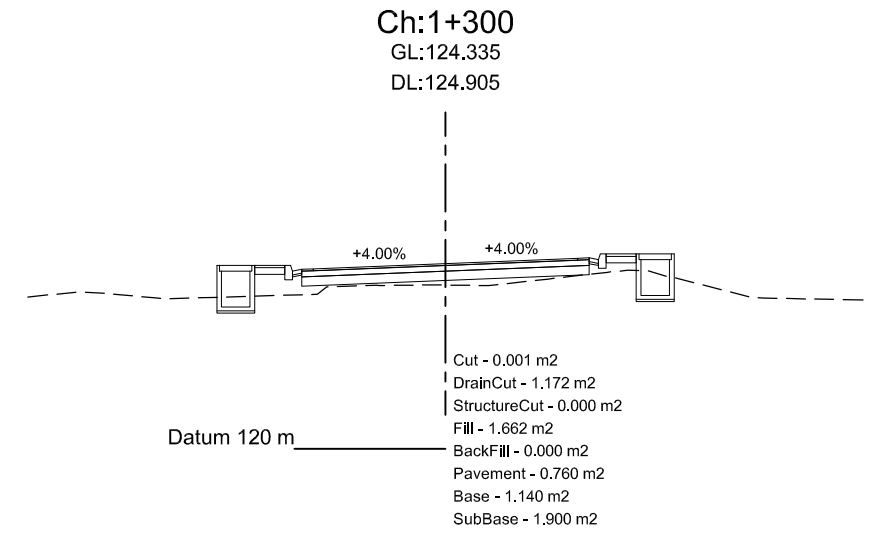
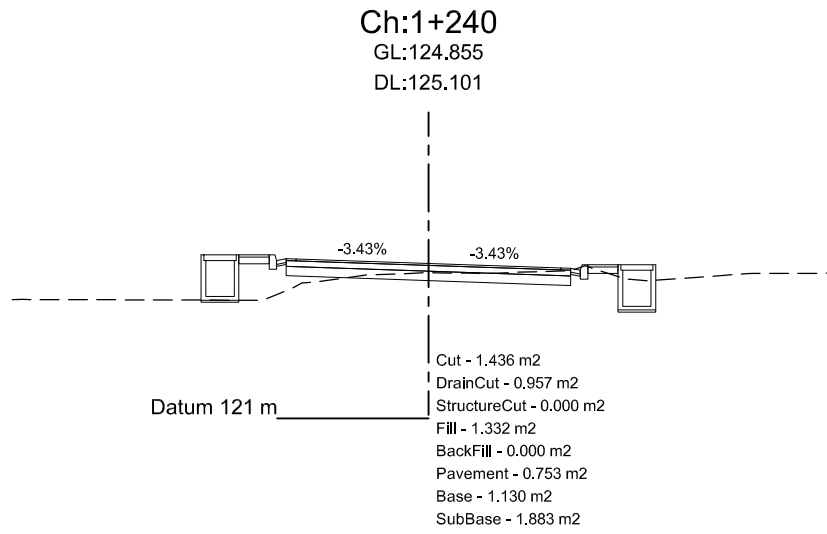
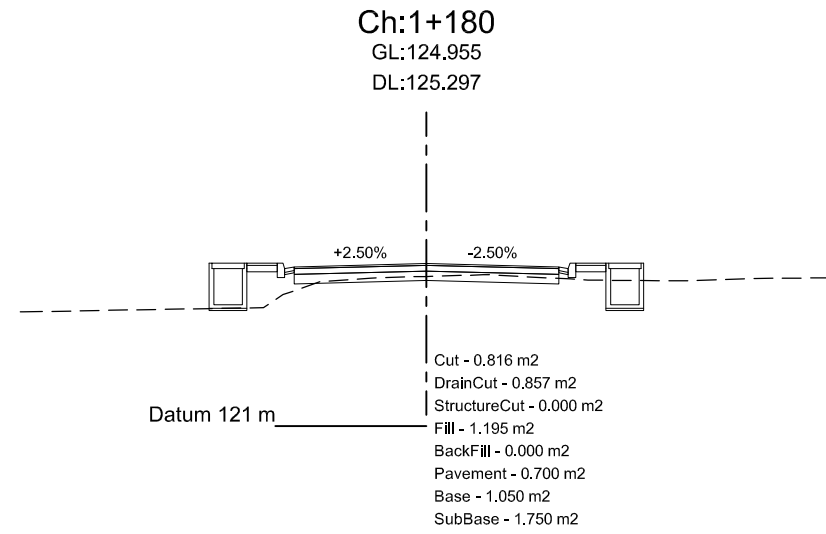
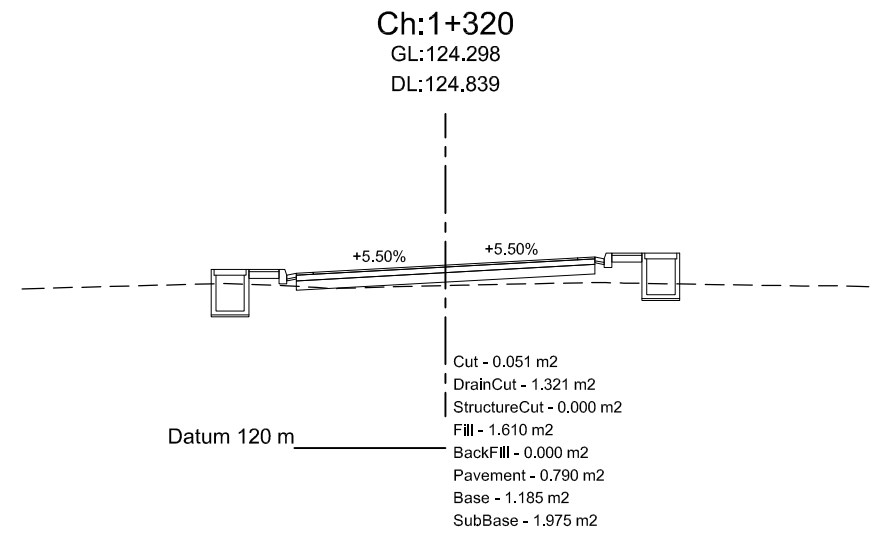
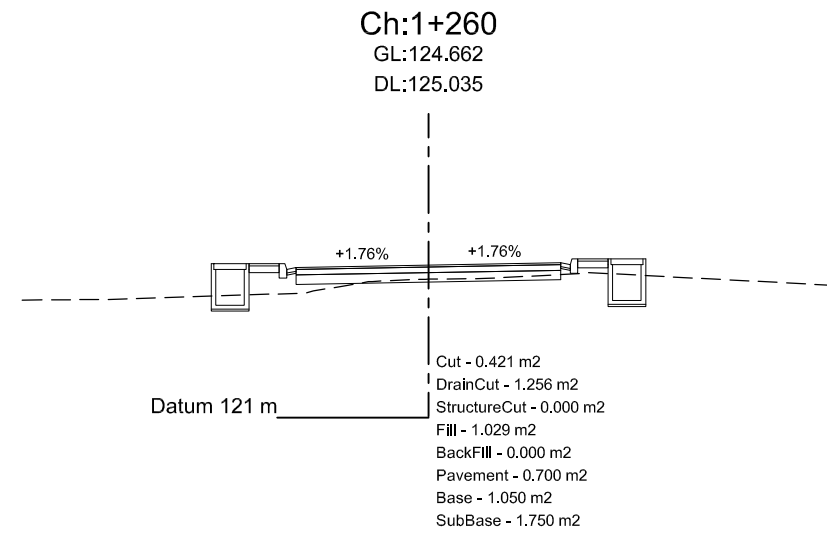
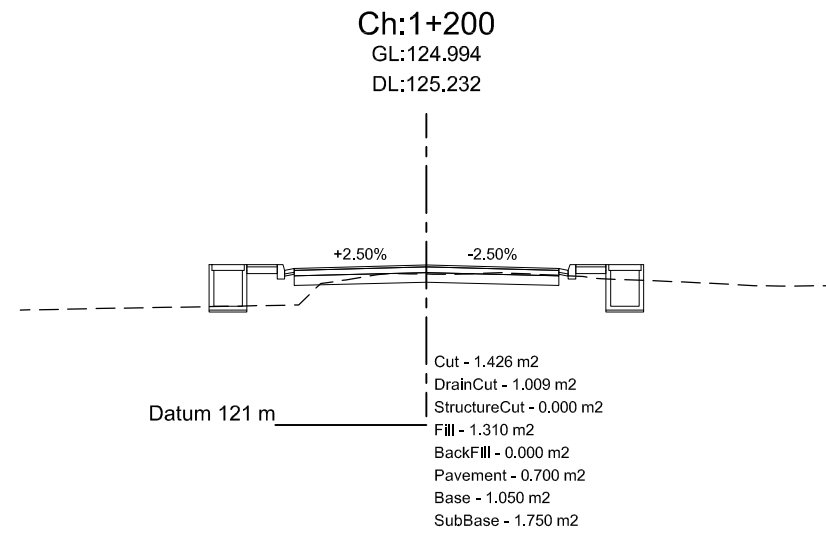

Department of Urban Development & Building Construction (DUDBC)
Regional Urban Development Project (RUDP)
West Urban Corridor (WUC) Development Project
Babarmahal, Kathmandu, Nepal

Reviewed & Designed By :
DOHWA Engineering Co. Ltd.
in Association with
ERMIC (P.) Ltd., SILT Consultants (P.) Ltd., and
DIGICON (P.) Ltd.
Mid- Baneshwor, Kathmandu
Tel: 01- 4589393

Consultant
Team Leader : YOO CHANGMIN
Reviewed By : YAGYA BAHADUR MALLA
Designed By : MANJU MUNANKARMI

Client
Approved By :
Checked By :

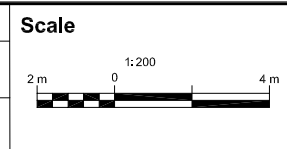

Cross-Section
BHALUHIPUL-MEDICAL COLLEGE-
BHATATOL-MUKHIYATOL-PIPARHIYA-
SINGHA-MUNICIPALITY
CH 0+000 - 7+503.82 Km

REV : MAY 2024
DRG NO : DM/RD/CS/8
CHAINAGE : 1+160-1+320
SHEET NO : 8

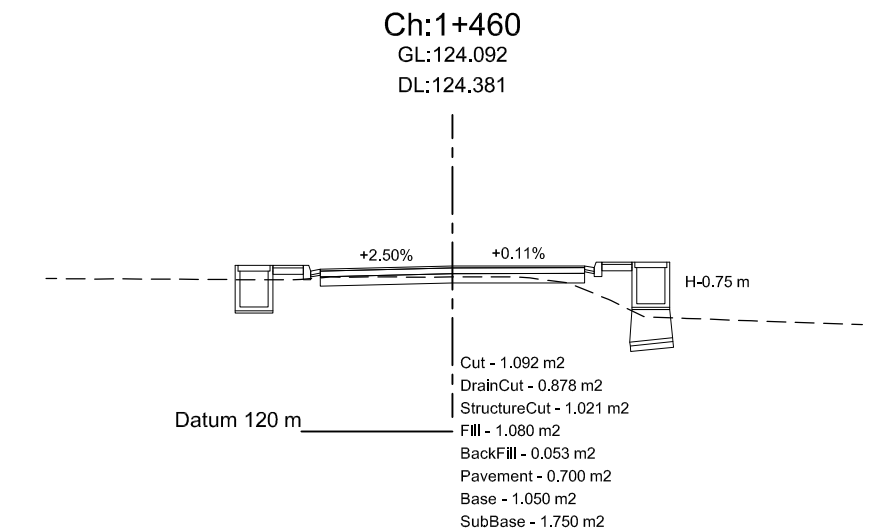
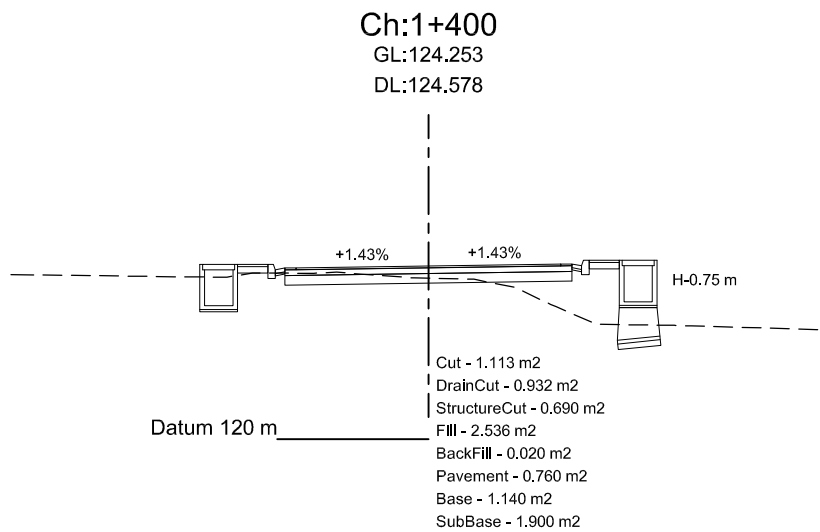
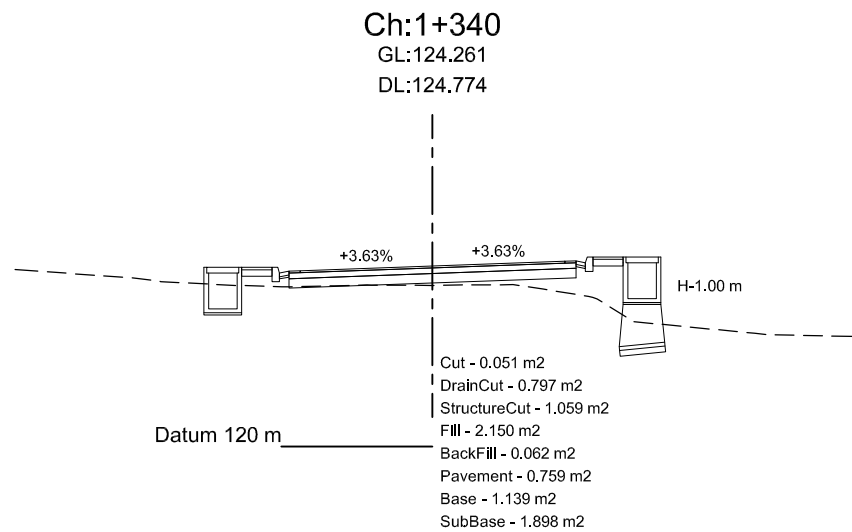
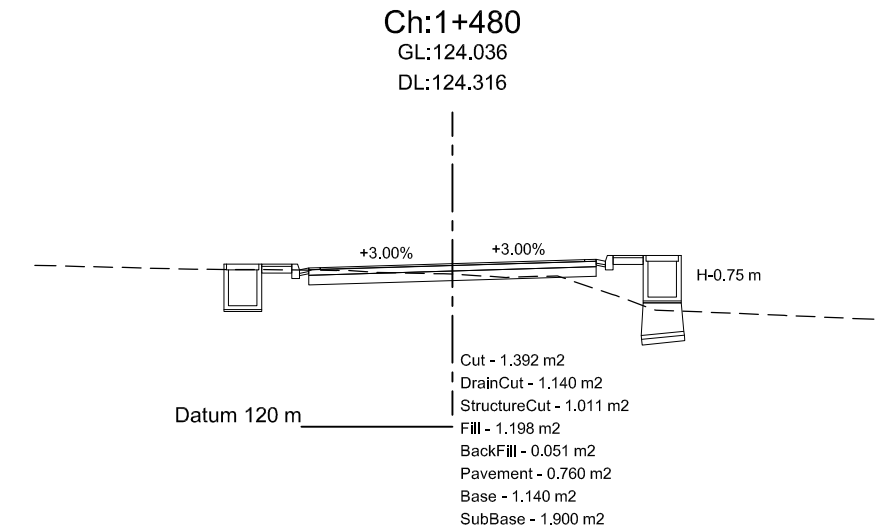
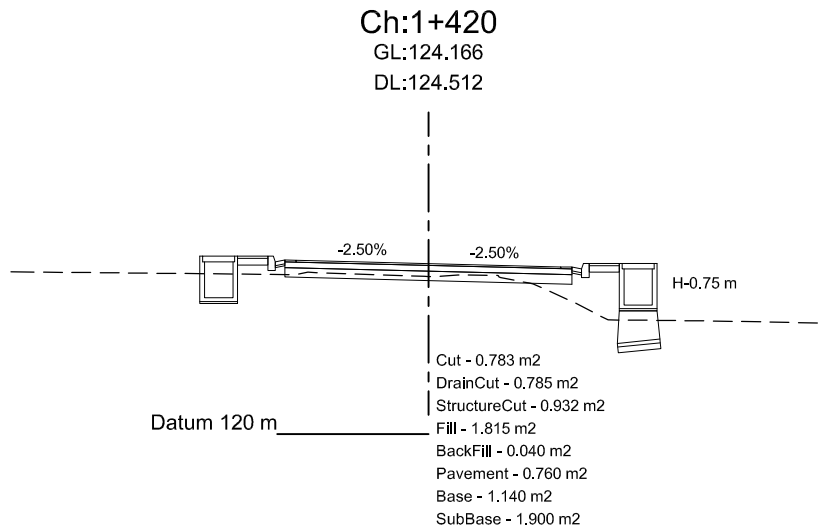
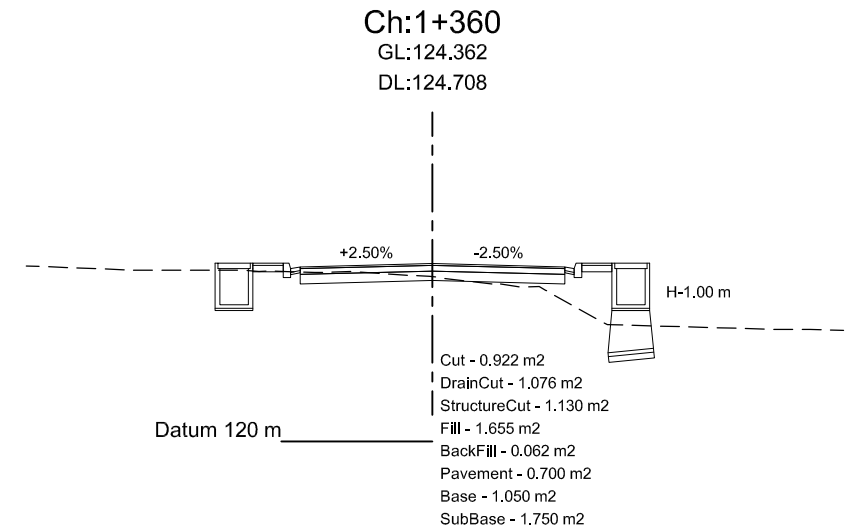
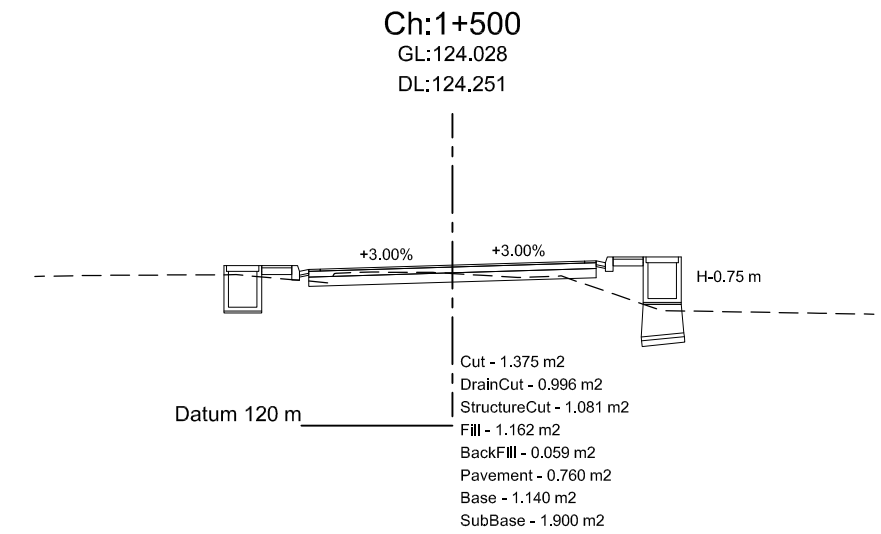
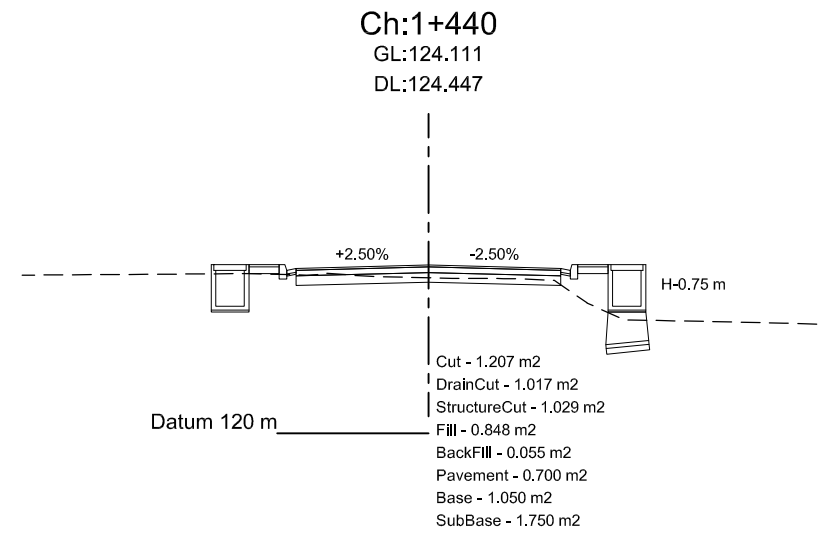
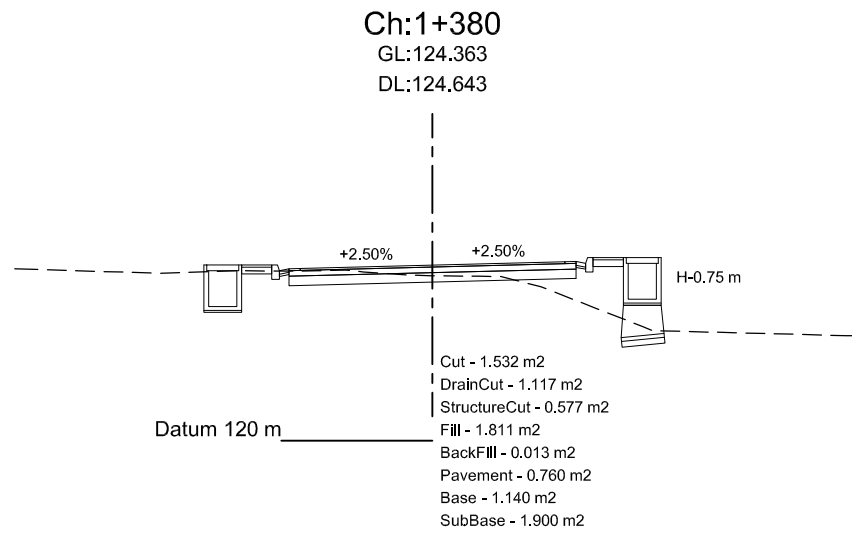

Department of Urban Development & Building
Construction (DUDBC)
Regional Urban Development Project (RUDP)
West Urban Corridor (WUC) Development Project
Babarmahal, Kathmandu, Nepal

Reviewed & Designed By :
DOHWA Engineering Co. Ltd.
in Association with
ERMIC (P.) Ltd., SILT Consultants (P.) Ltd., and
DIGICON (P.) Ltd.
Mid- Baneshwor, Kathmandu
Tel: 01- 4589393

Consultant
Team Leader : YOO CHANGMIN
Reviewed By : YAGYA BAHADUR MALLA
Designed By : MANJU MUNANKARMI

Client
Approved By :
Checked By :

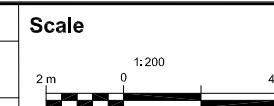

Cross-Section
BHALUHIPUL-MEDICAL COLLEGE-
BHATATOL-MUKHIYATOL-PIPARHIYA-
SINGHA-MUNICIPALITY
CH 0+000 - 7+503.82 Km

REV : MAY 2024
DRG NO : DM/RD/CS/9
CHAINAGE : 1+340-1+500
SHEET NO : 9

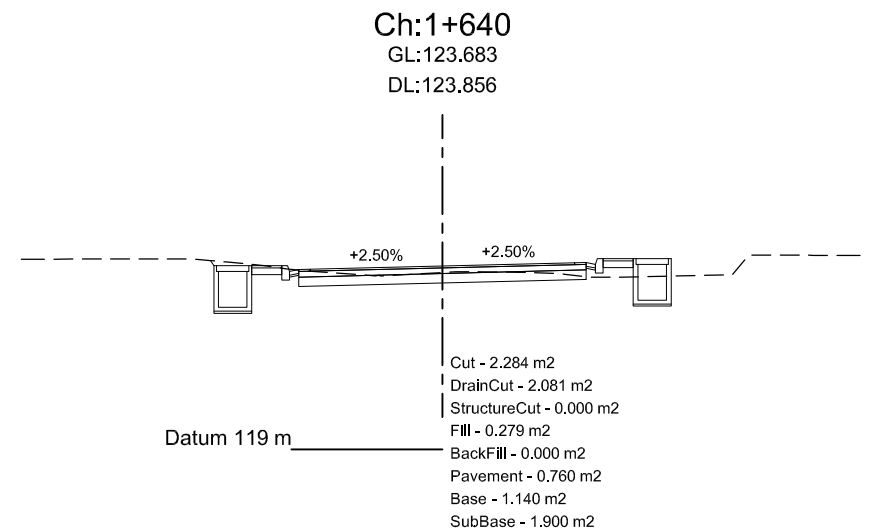
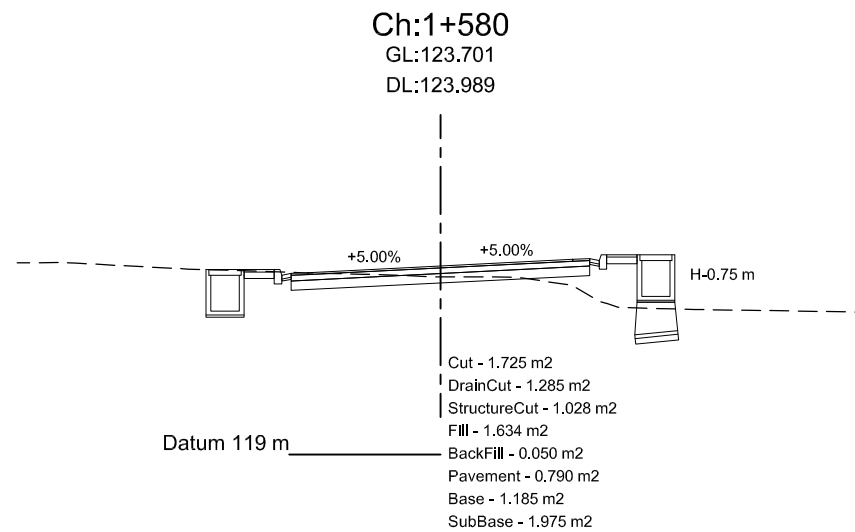
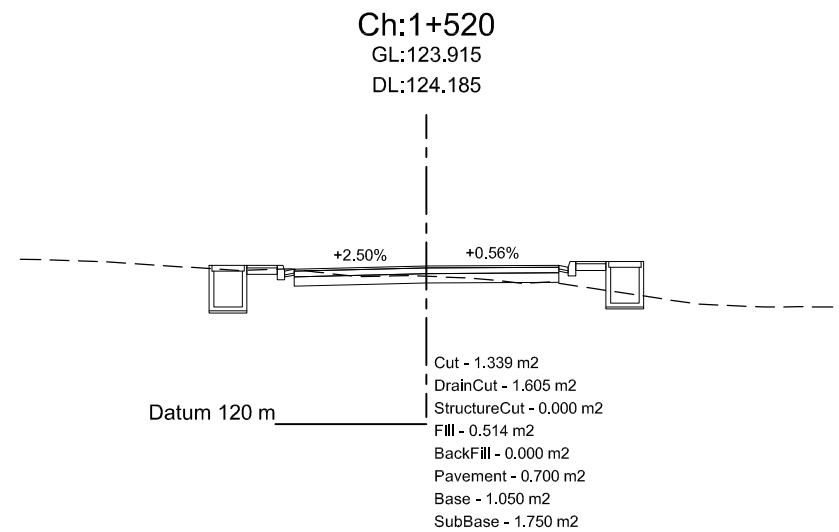
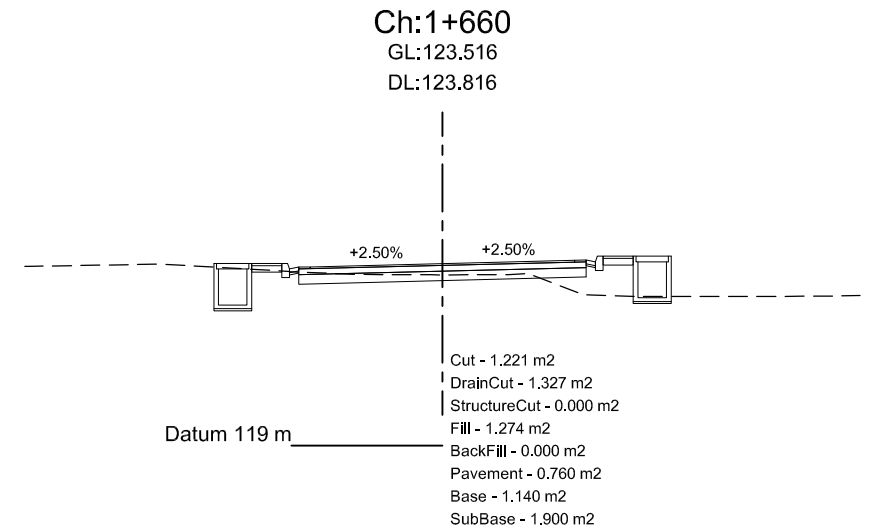
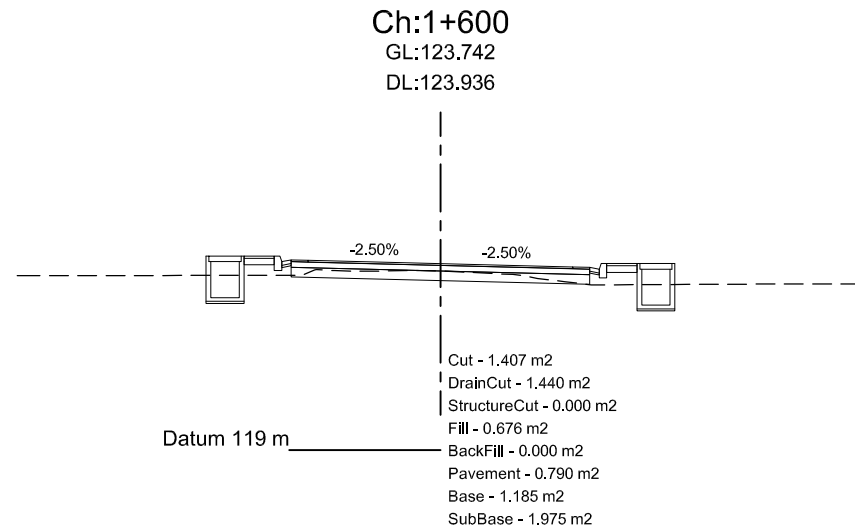
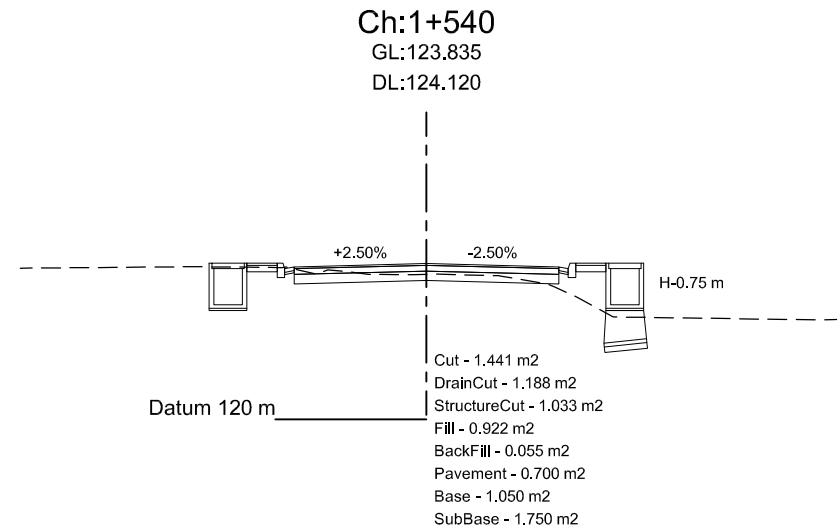
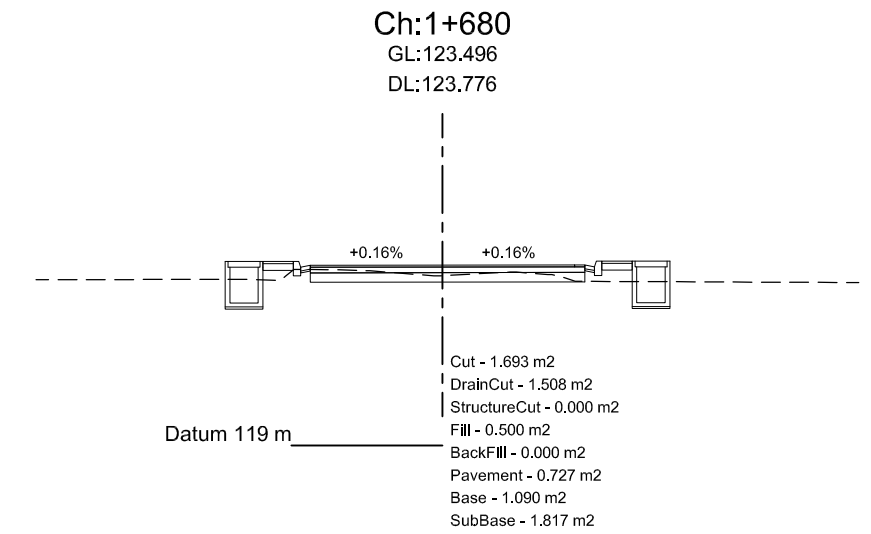
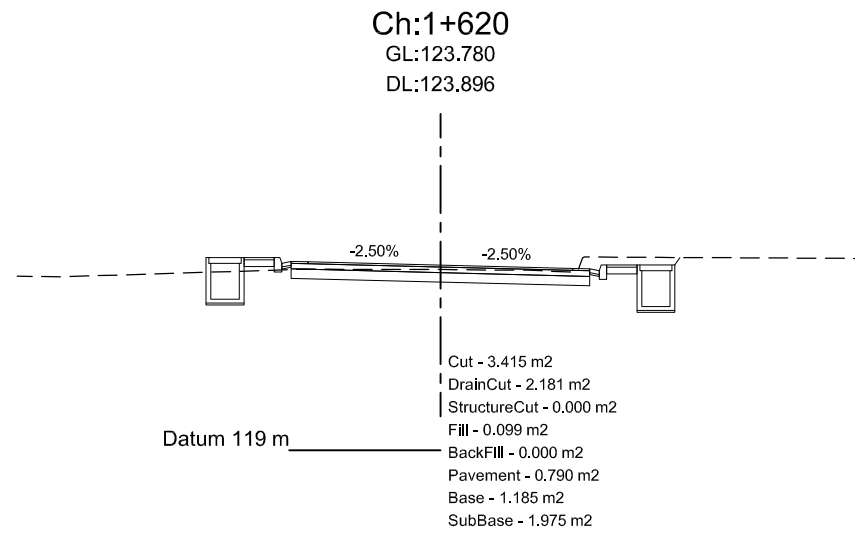
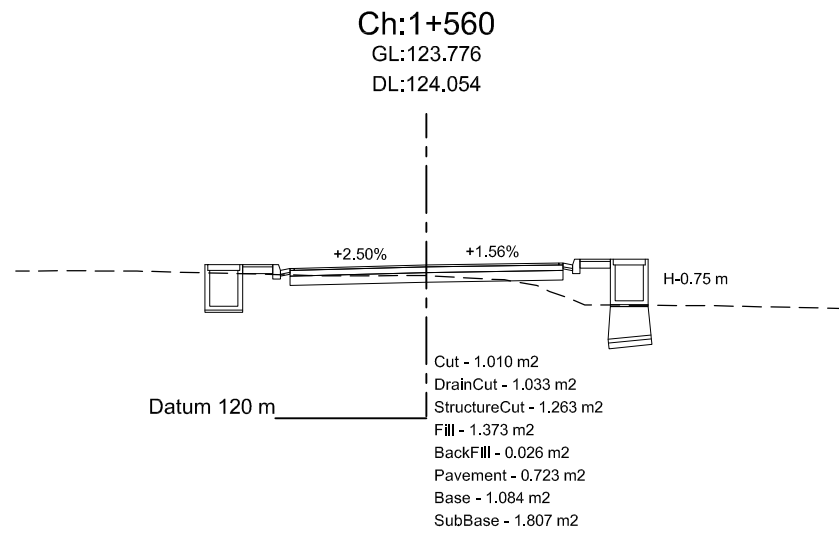

Department of Urban Development & Building Construction (DUDBC)
Regional Urban Development Project (RUDP)
West Urban Corridor (WUC) Development Project
Babarmahal, Kathmandu, Nepal

Reviewed & Designed By :
DOHWA Engineering Co. Ltd.
in Association with
ERMIC (P.) Ltd., SILT Consultants (P.) Ltd., and
DIGICON (P.) Ltd.
Mid-Baneshwor, Kathmandu
Tel: 01-4589393

Consultant
Team Leader : YOO CHANGMIN
Reviewed By : YAGYA BAHADUR MALLA
Designed By : MANJU MUNANKARMI

Client
Approved By :
Checked By :

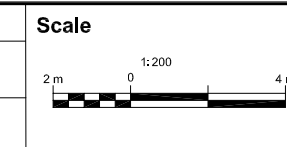

Cross-Section
BHALUHIPUL-MEDICAL COLLEGE-
BHATATOL-MUKHIYATOL-PIPARHIYA-
SINGHA-MUNICIPALITY
CH 0+000 - 7+503.82 Km

REV : MAY 2024
DRG NO : DM/RD/CS/10
CHAINAGE : 1+520-1+680
SHEET NO : 10

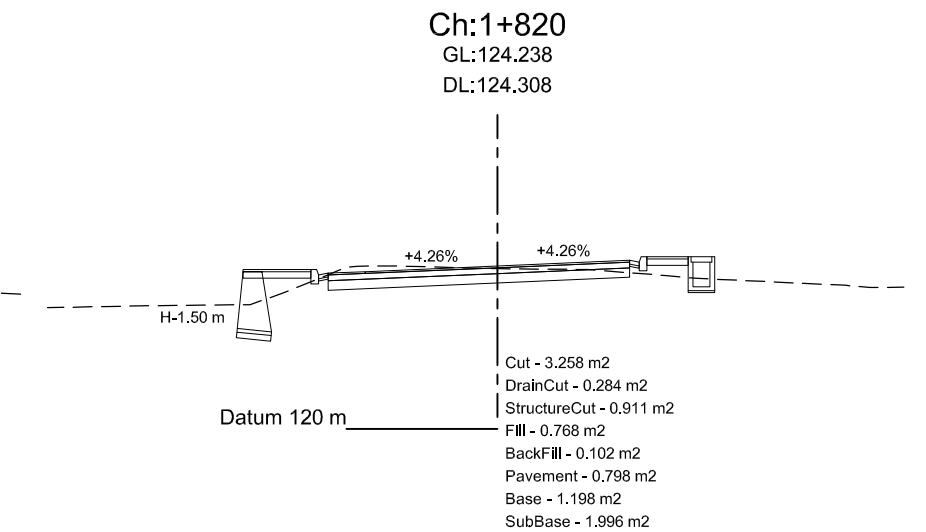
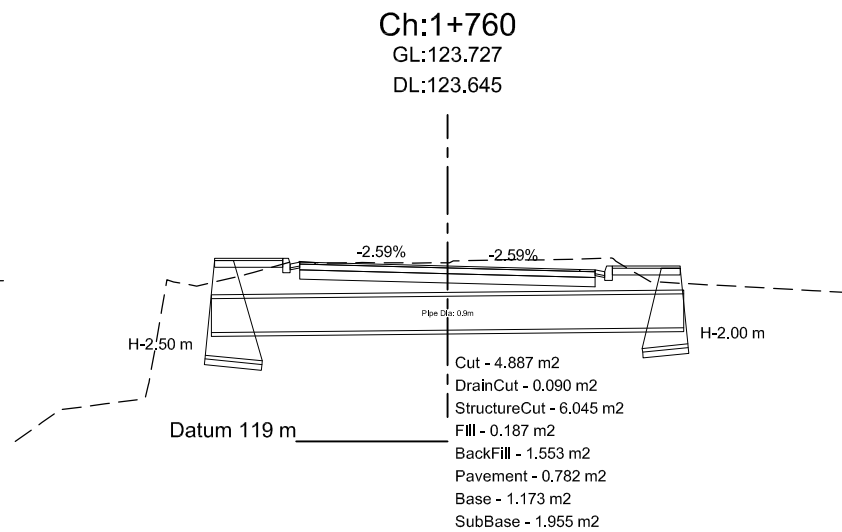
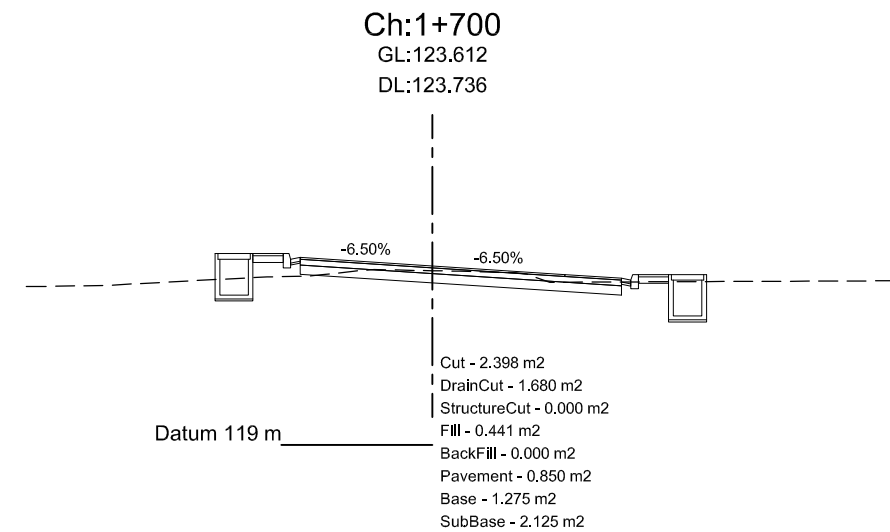
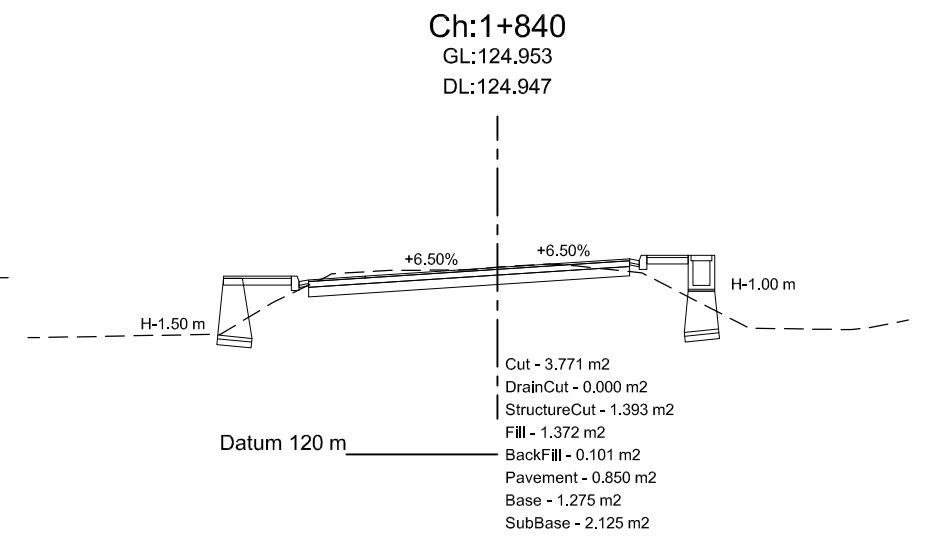
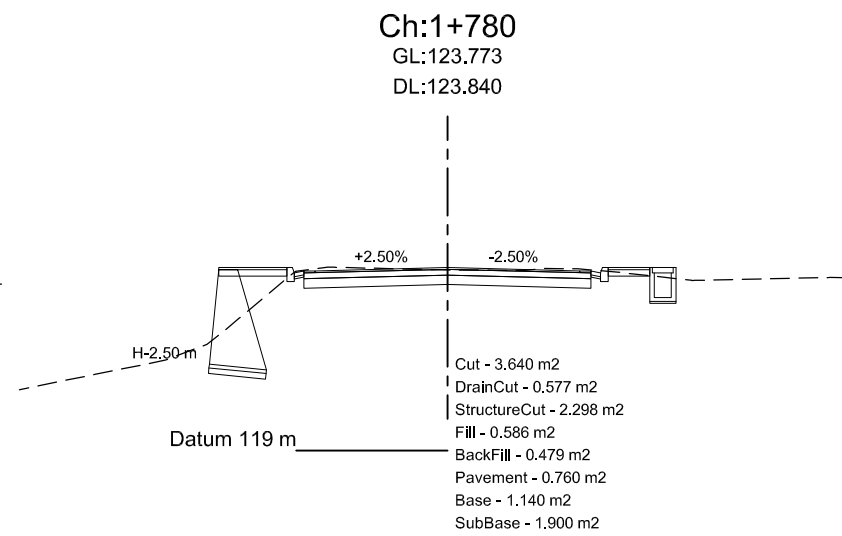
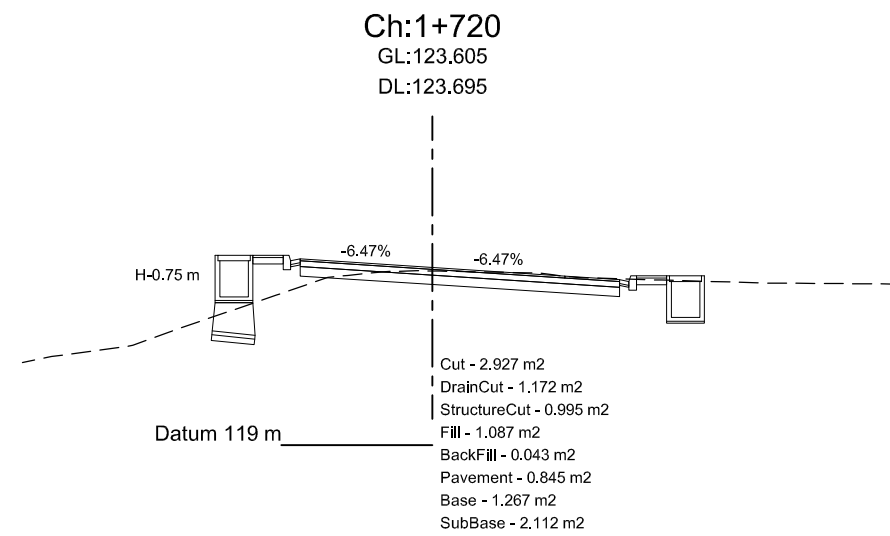
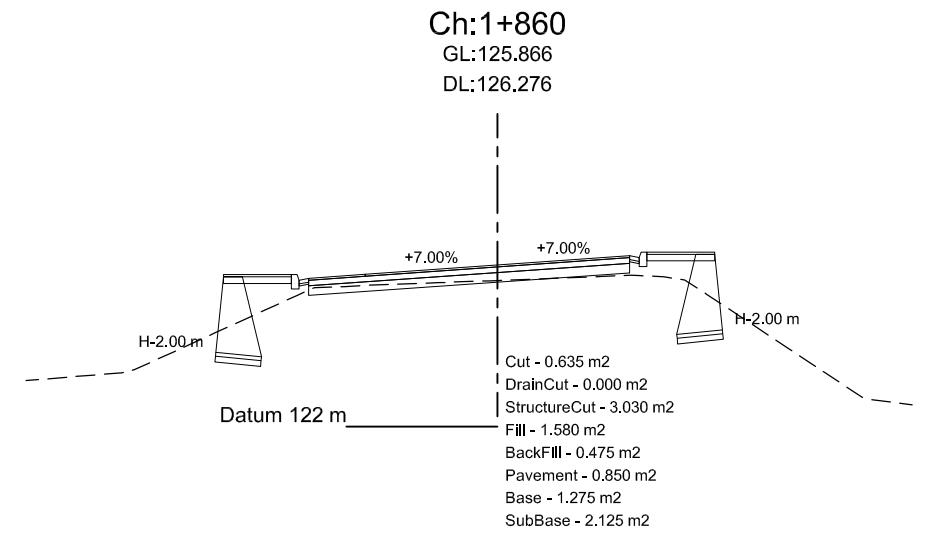
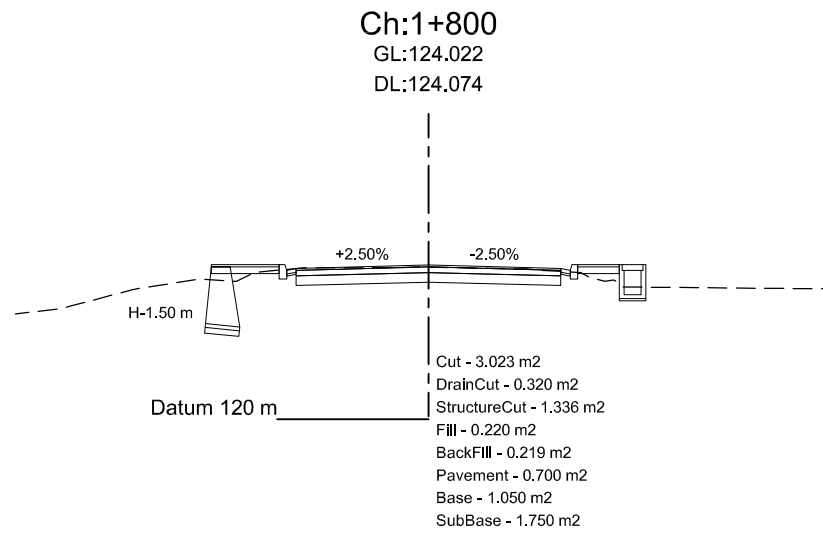
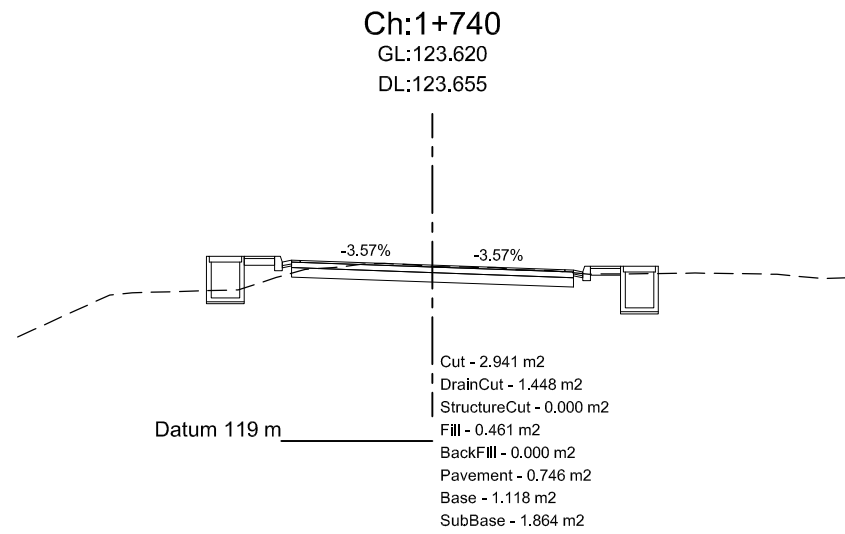

Department of Urban Development & Building
Construction (DUDBC)
Regional Urban Development Project (RUDP)
West Urban Corridor (WUC) Development Project
Babarmahal, Kathmandu, Nepal

Reviewed & Designed By :
DOHWA Engineering Co. Ltd.
in Association with
ERMIC (P.) Ltd., SILT Consultants (P.) Ltd., and
DIGICON (P.) Ltd.
Mid- Baneshwor, Kathmandu
Tel: 01- 4589393

Consultant
Team Leader : YOO CHANGMIN
Reviewed By : YAGYA BAHADUR MALLA
Designed By : MANJU MUNANKARMI

Client
Approved By :
Checked By :

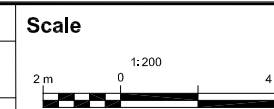

Cross-Section
BHALUHIPUL-MEDICAL COLLEGE-
BHATATOL-MUKHIYATOL-PIPARHIYA-
SINGHA-MUNICIPALITY
CH 0+000 - 7+503.82 Km

REV : MAY 2024
DRG NO : DM/RD/CS/11
CHAINAGE : 1+700-1+860
SHEET NO : 11

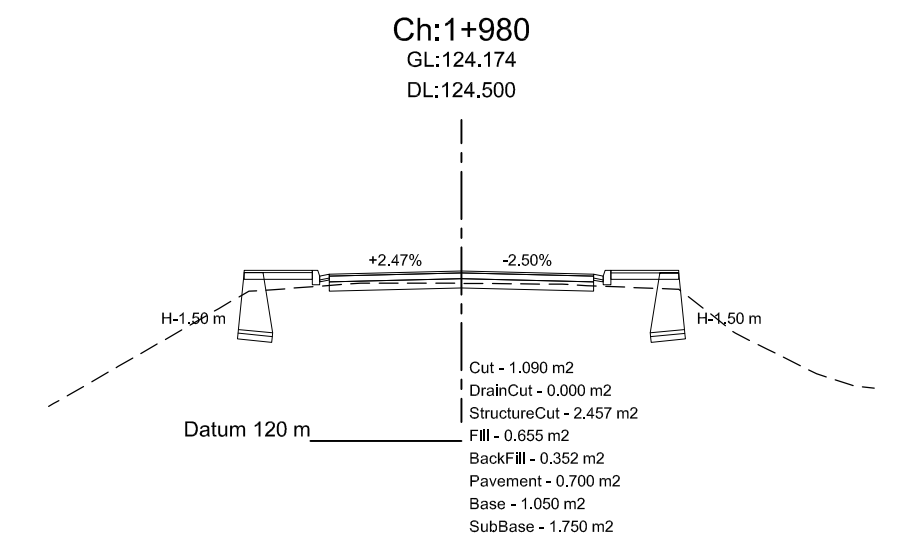
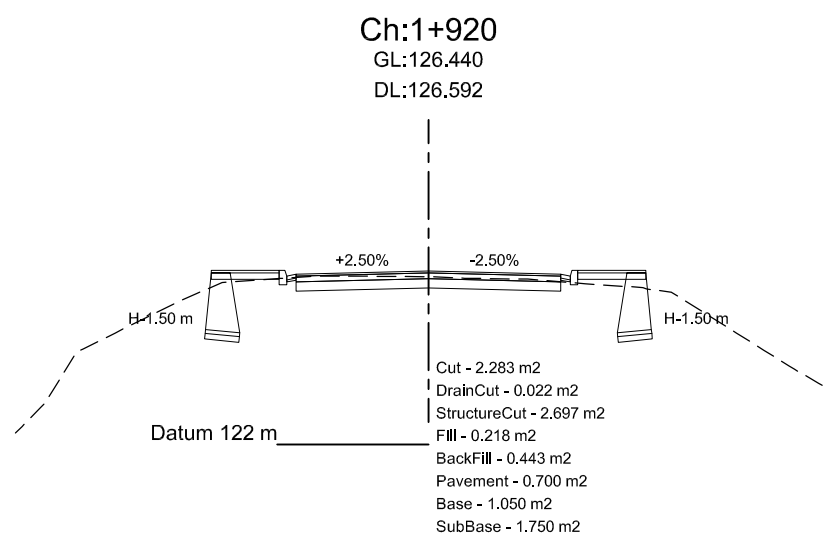
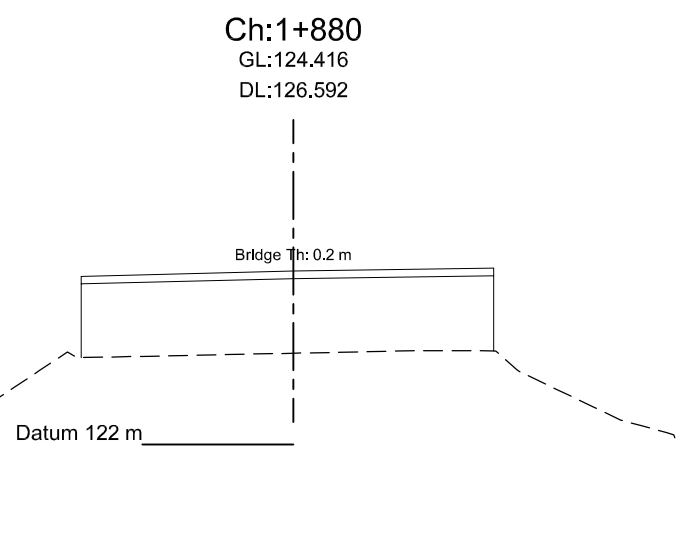
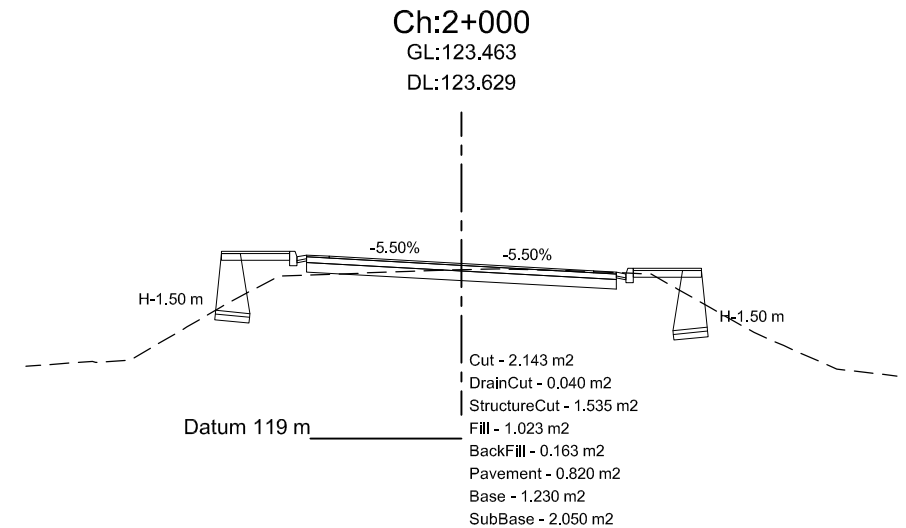
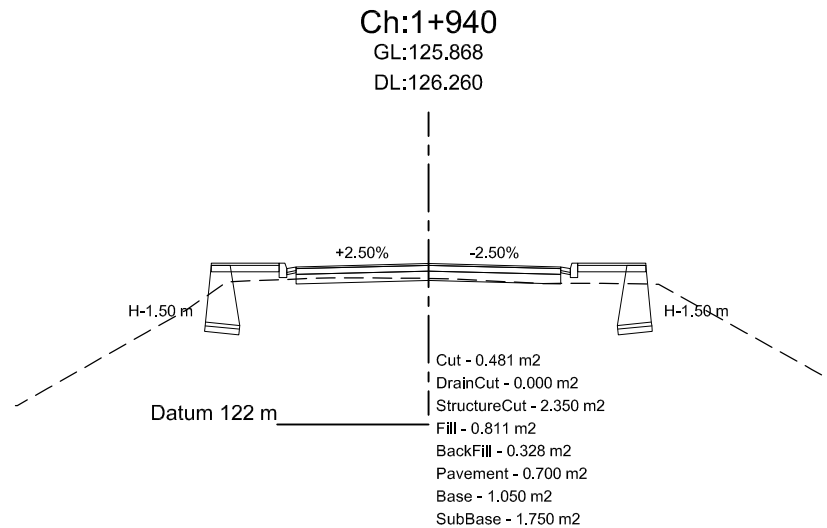
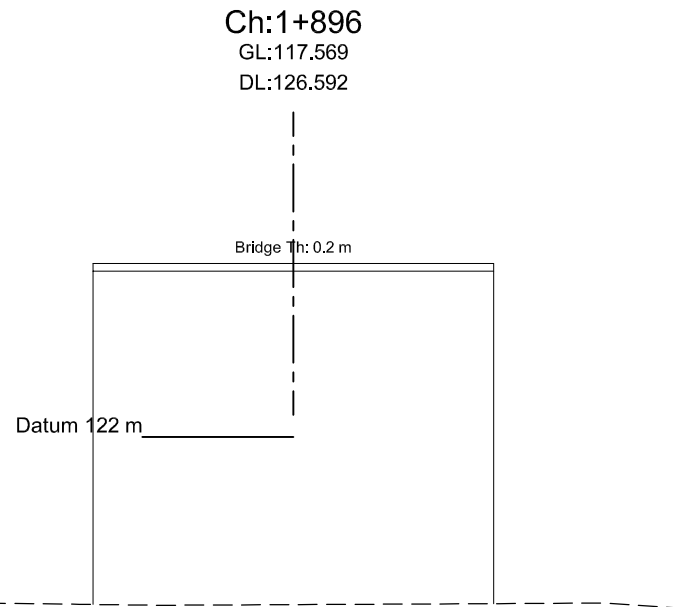
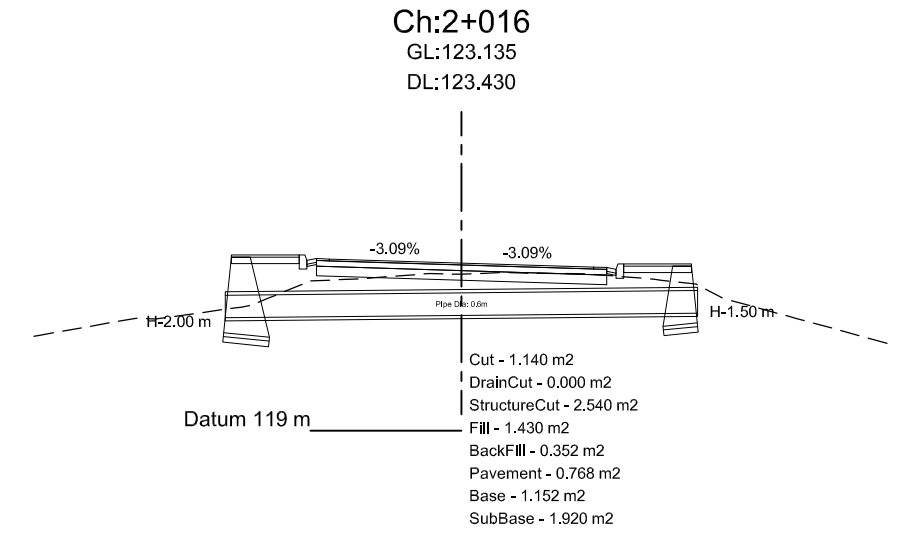
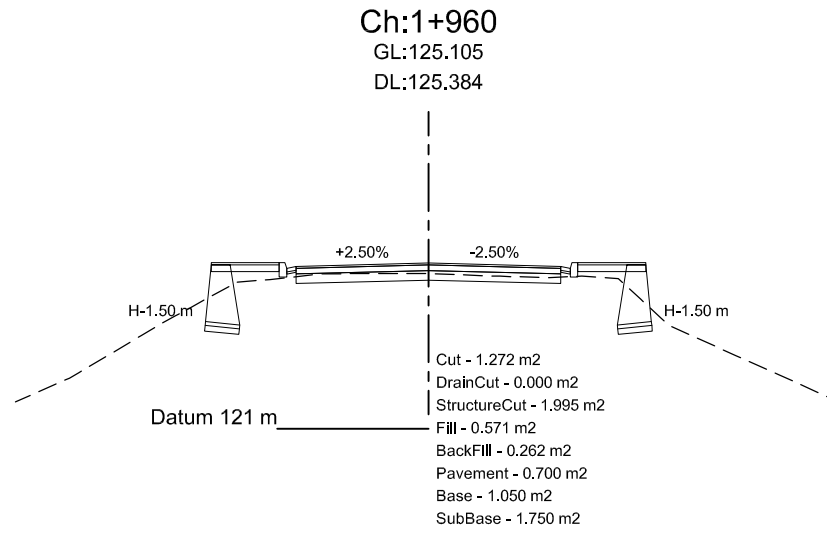
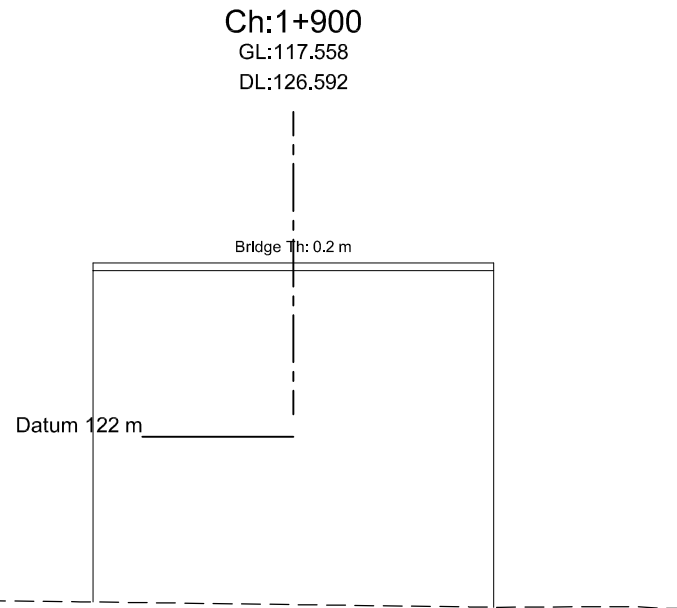

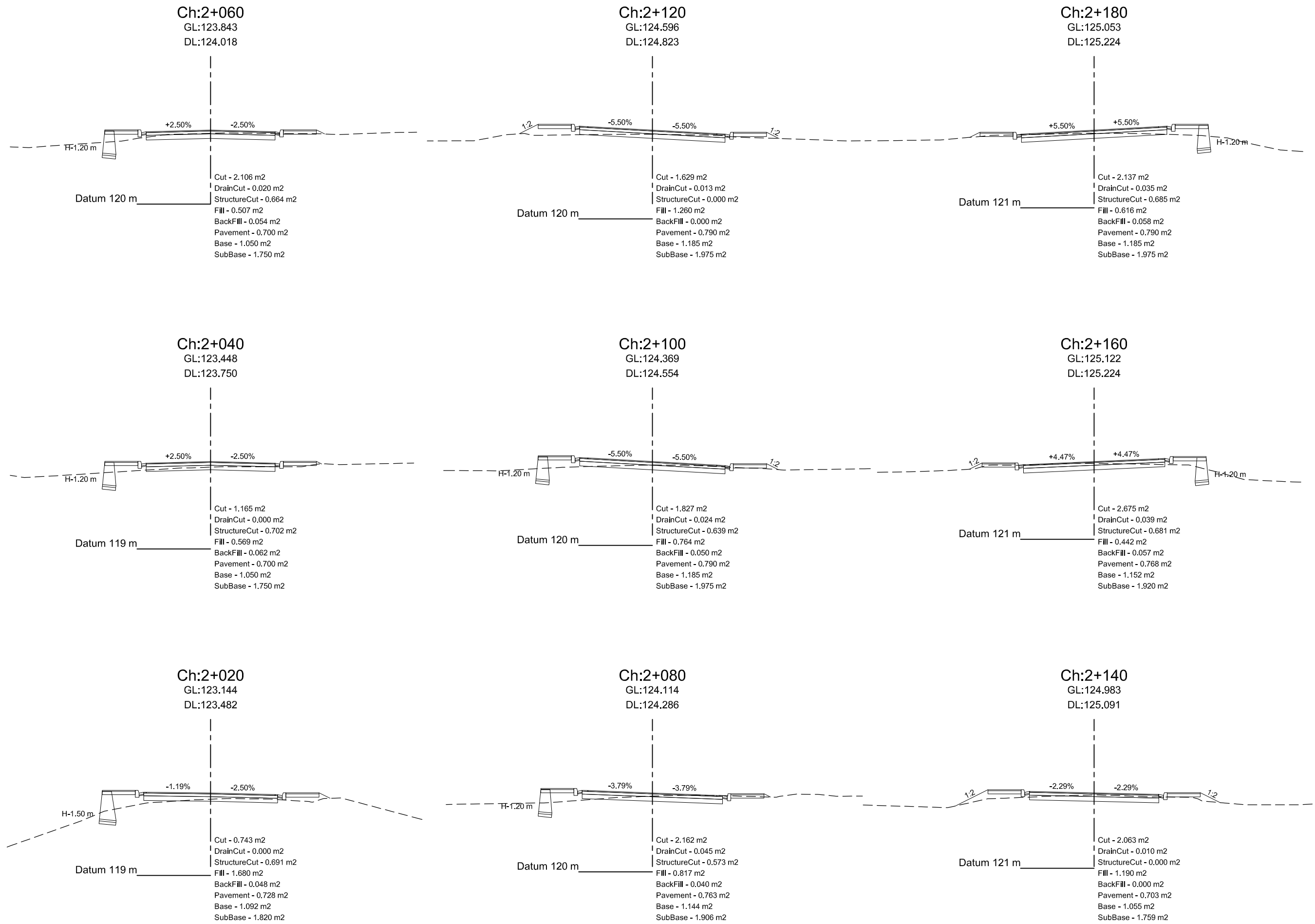

Ch:2+240

GL:119.303

DL:125.224

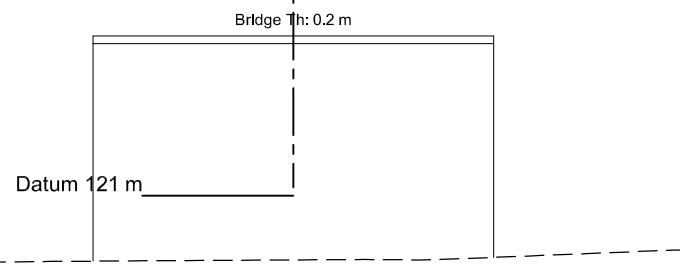

Ch:2+280

GL:118.216

DL:125.224

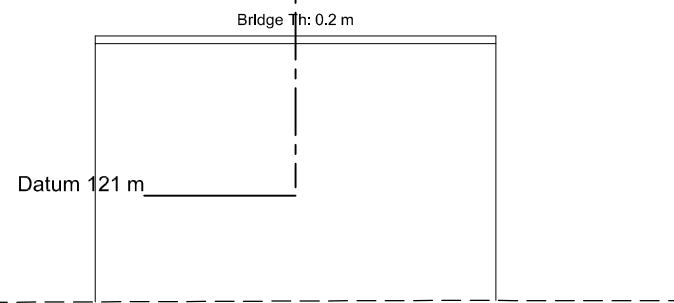

Ch:2+340

GL:124.591

DL:124.946

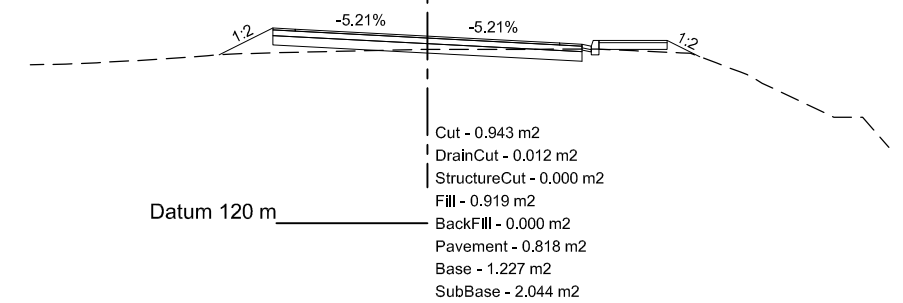

Ch:2+220

GL:120.311

DL:125.224

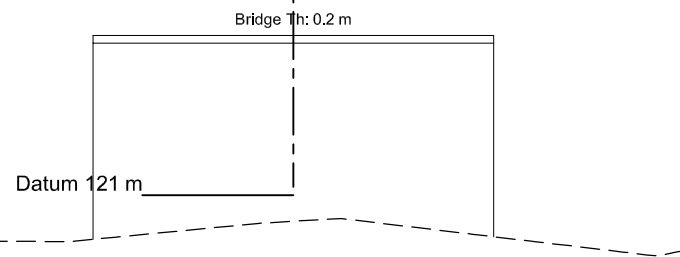

Ch:2+260

GL:118.324

DL:125.224

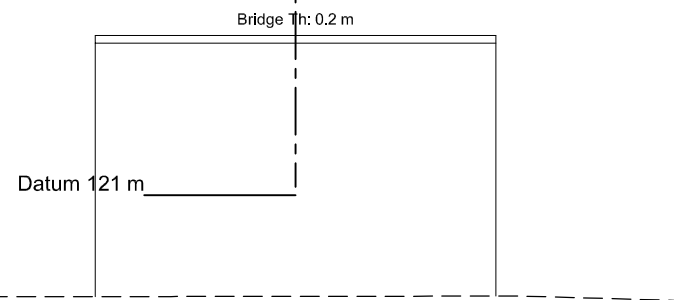

Ch:2+320

GL:124.919

DL:125.181

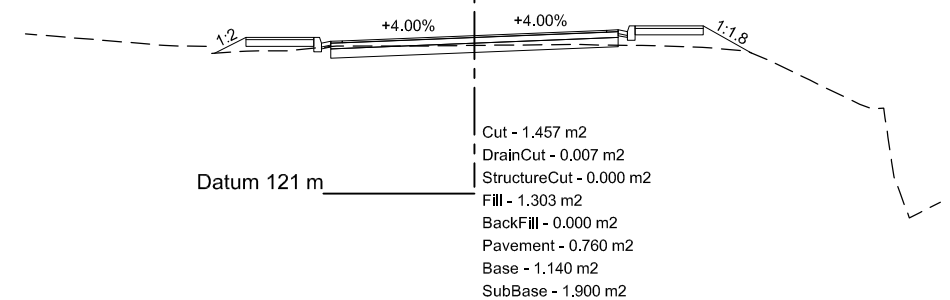

Ch:2+200

GL:124.932

DL:125.224

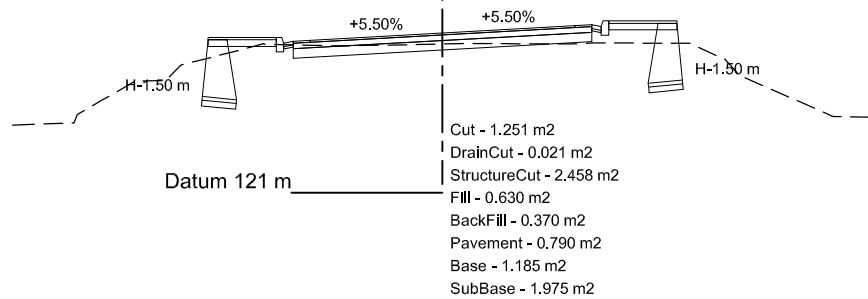

Ch:2+250

GL:118.612

DL:125.224

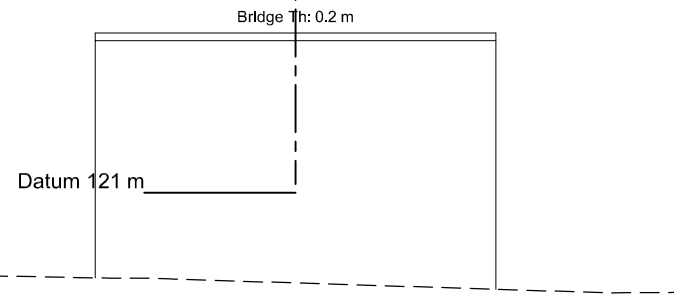

Ch:2+300

GL:125.033

DL:125.224

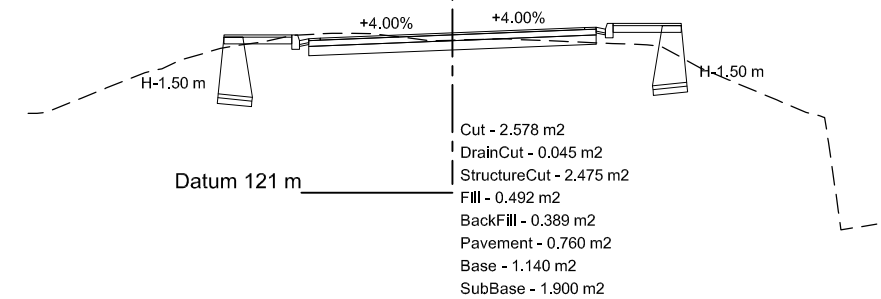

Department of Urban Development & Building
 Construction (DUDBC)
Regional Urban Development Project (RUDP)
 West Urban Corridor (WUC) Development Project
 Babarmahal, Kathmandu, Nepal

Reviewed & Designed By :
 DOHWA Engineering Co. Ltd.
 in Association with
 ERMC (P.) Ltd., SILT Consultants (P.) Ltd., and
 DIGICON (P.) Ltd.
 Mid-Baneshwor, Kathmandu
 Tel: 01-4589393

Consultant
Team Leader : YOO CHANGMIN
Reviewed By : YAGYA BAHADUR MALLA
Designed By : MANJU MUNANKARMI

Client
Approved By :
Checked By :

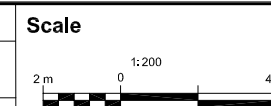

Cross-Section
BHATHIPUL-MEDICAL COLLEGE-
BHATHATOL-MUKHIYATOL-PIPARHIYA-
SINGHA-MUNICIPALITY
CH 0+000 - 7+503.82 Km

REV : MAY 2024
DRG NO : DM/RD/CS/14
CHAINAGE : 2+200-2+340
SHEET NO : 14

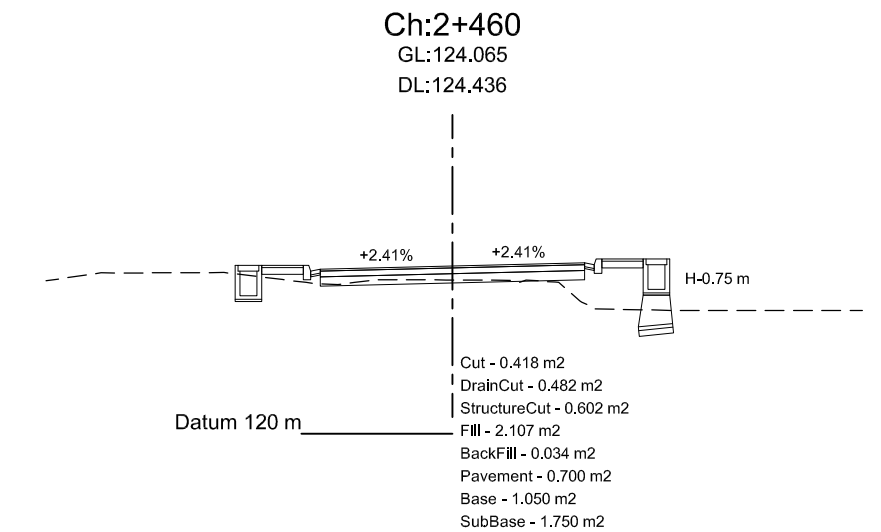
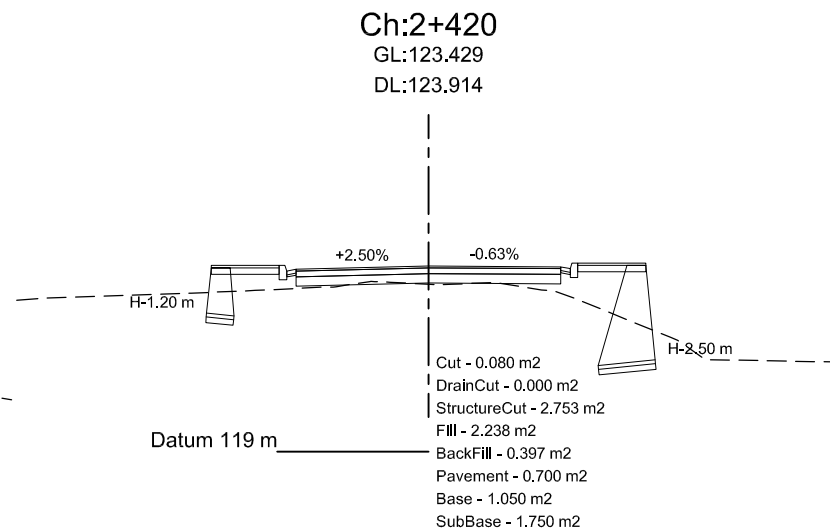
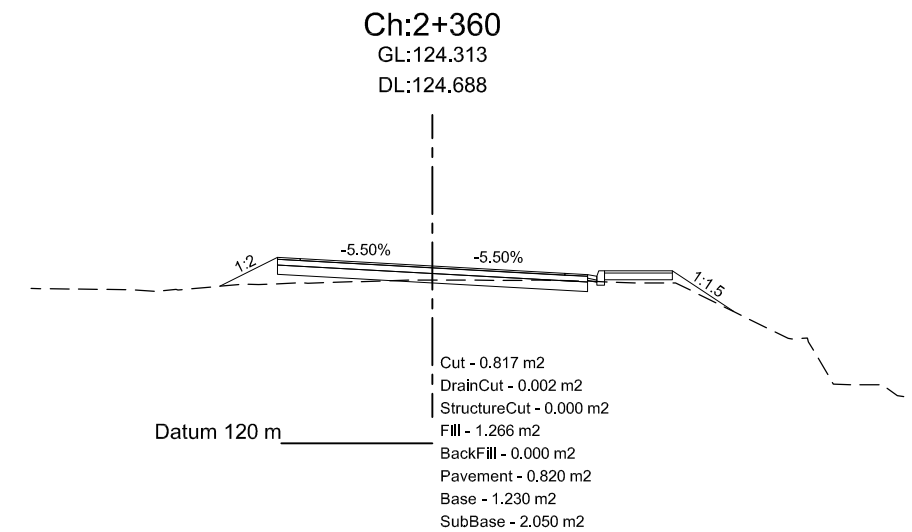
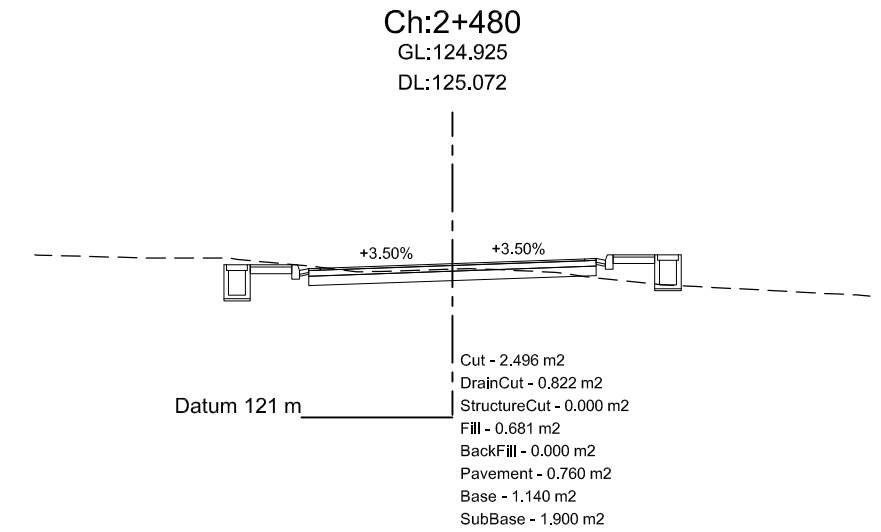
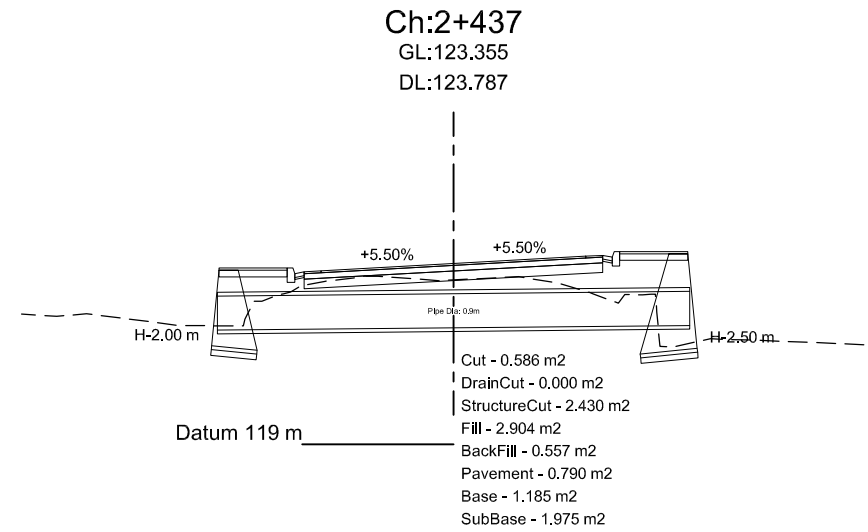
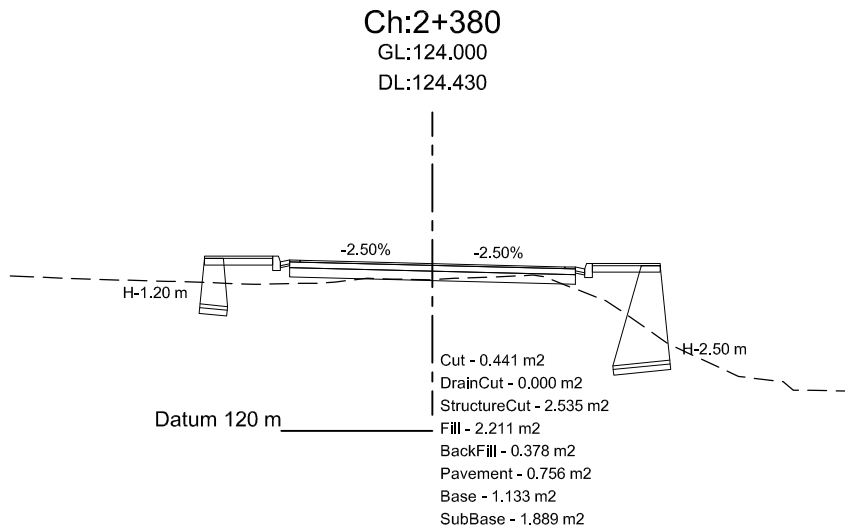
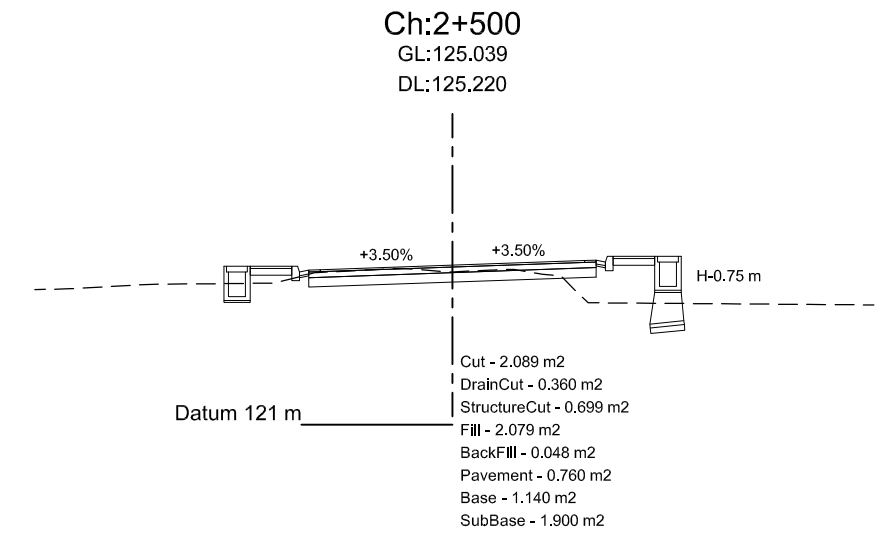
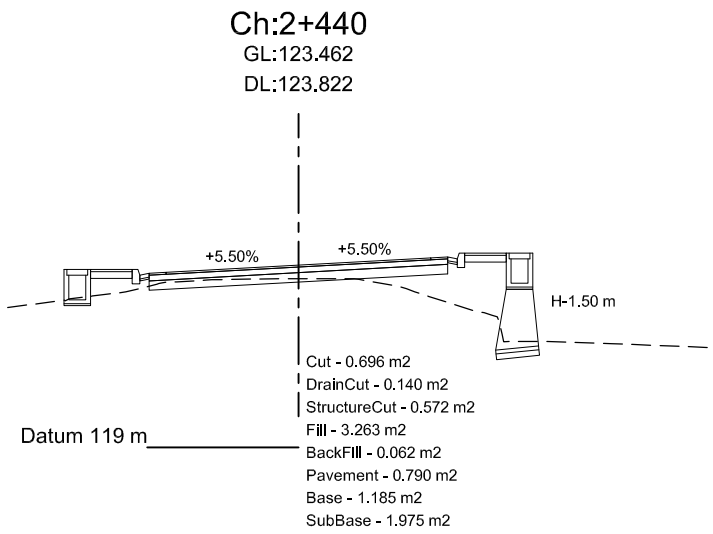
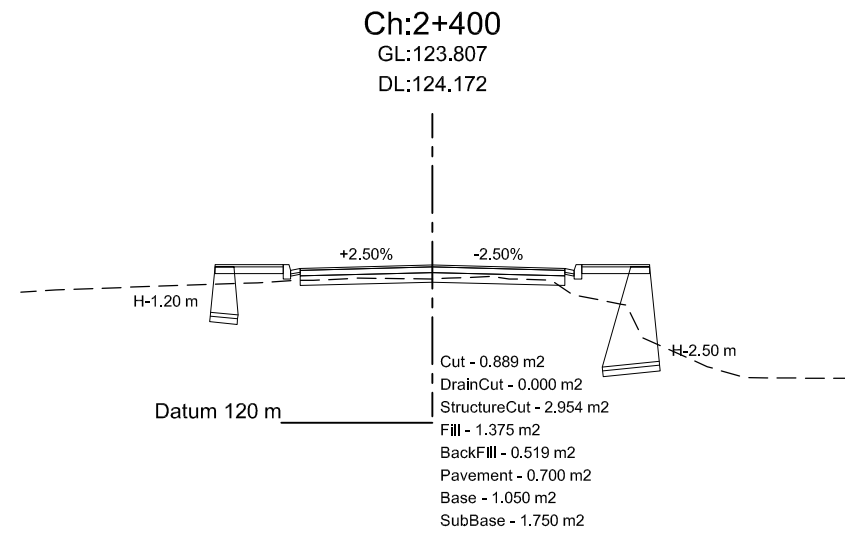

Department of Urban Development & Building
Construction (DUDBC)
Regional Urban Development Project (RUDP)
West Urban Corridor (WUC) Development Project
Babarmahal, Kathmandu, Nepal

Reviewed & Designed By :
DOHWA Engineering Co. Ltd.
in Association with
ERMIC (P.) Ltd., SILT Consultants (P.) Ltd., and
DIGICON (P.) Ltd.
Mid-Baneshwor, Kathmandu
Tel: 01-4589393

Consultant
Team Leader : YOO CHANGMIN
Reviewed By : YAGYA BAHADUR MALLA
Designed By : MANJU MUNANKARMI

Client
Approved By :
Checked By :

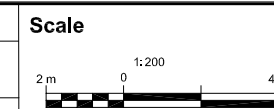

Cross-Section
BHALUHIPUL-MEDICAL COLLEGE-
BHATATOL-MUKHIYATOL-PIPARHIYA-
SINGHA-MUNICIPALITY
CH 0+000 - 7+503.82 Km

REV : MAY 2024
DRG NO : DM/RD/CS/15
CHAINAGE : 2+360-2+500
SHEET NO : 15

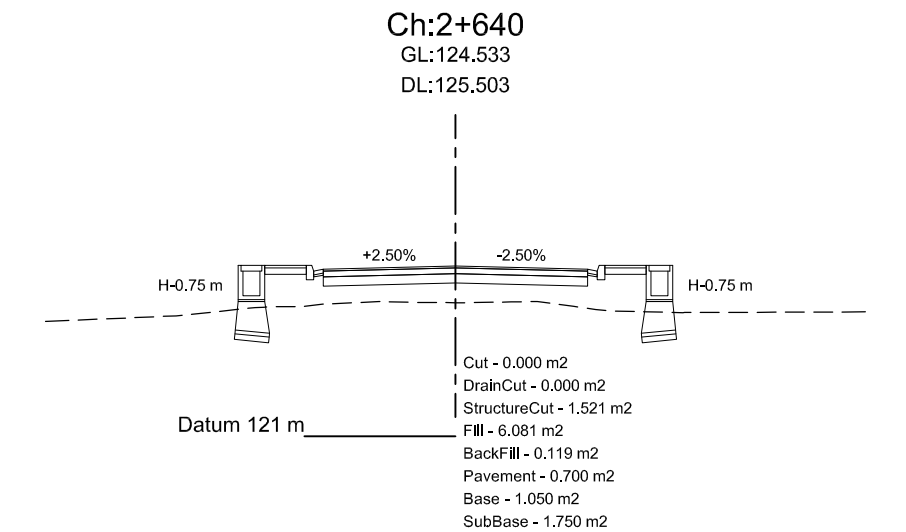
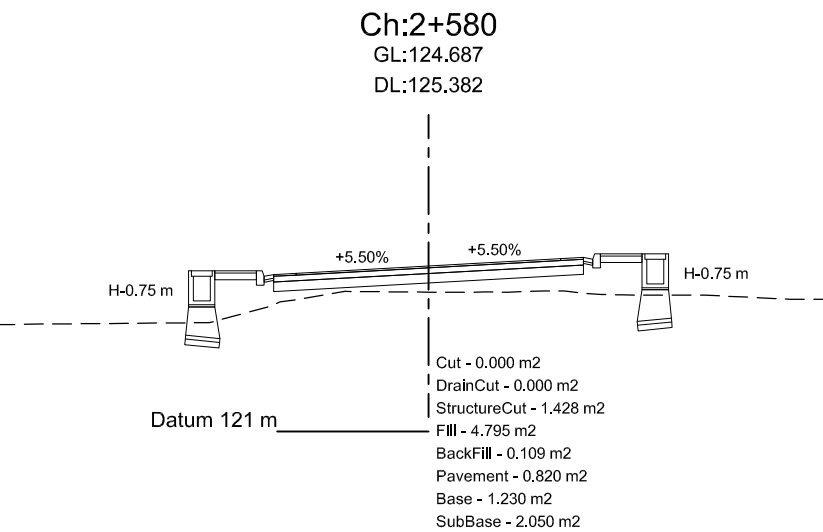
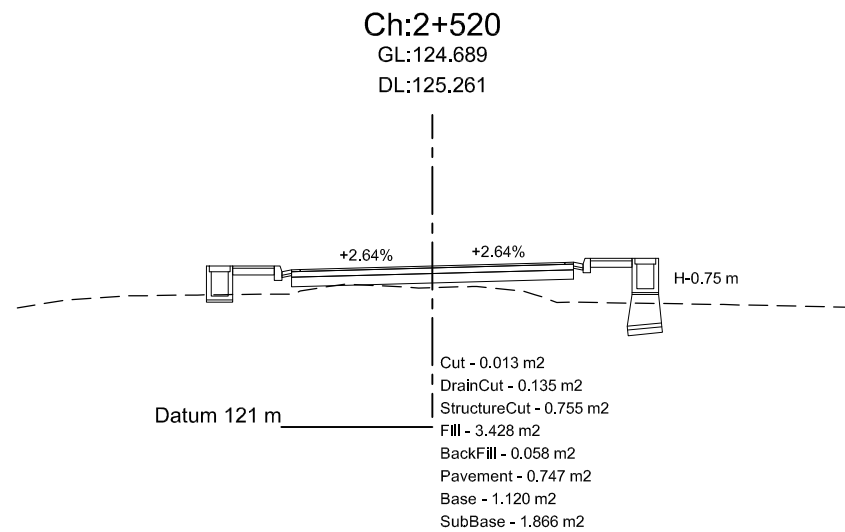
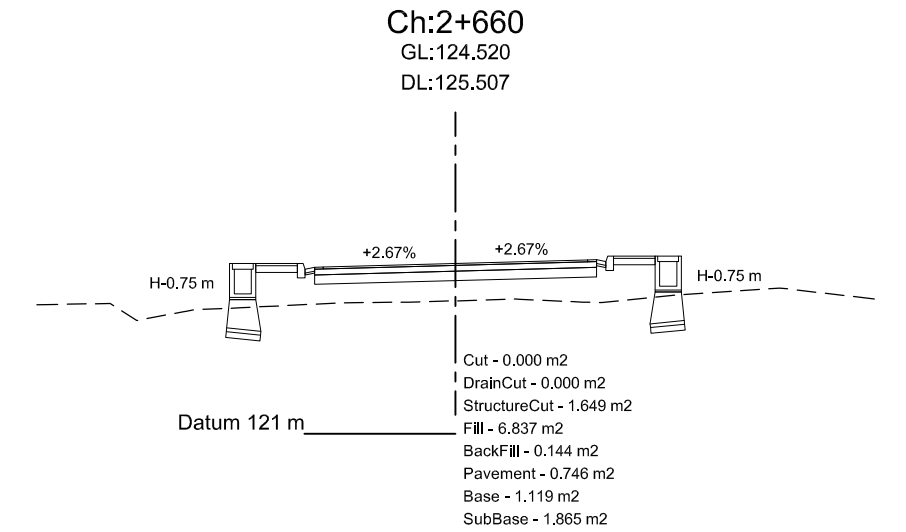
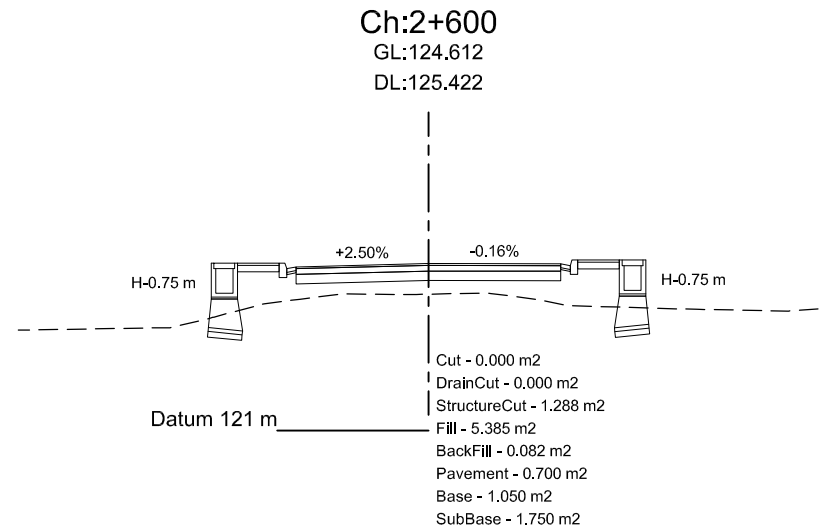
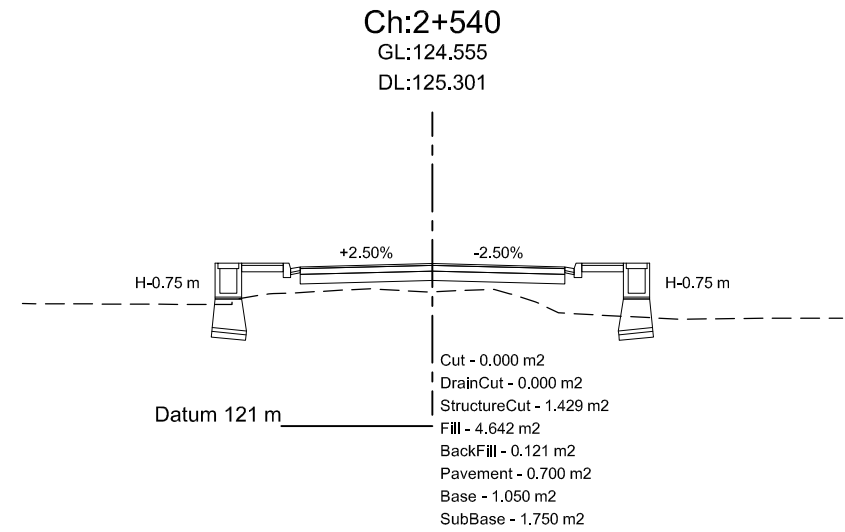
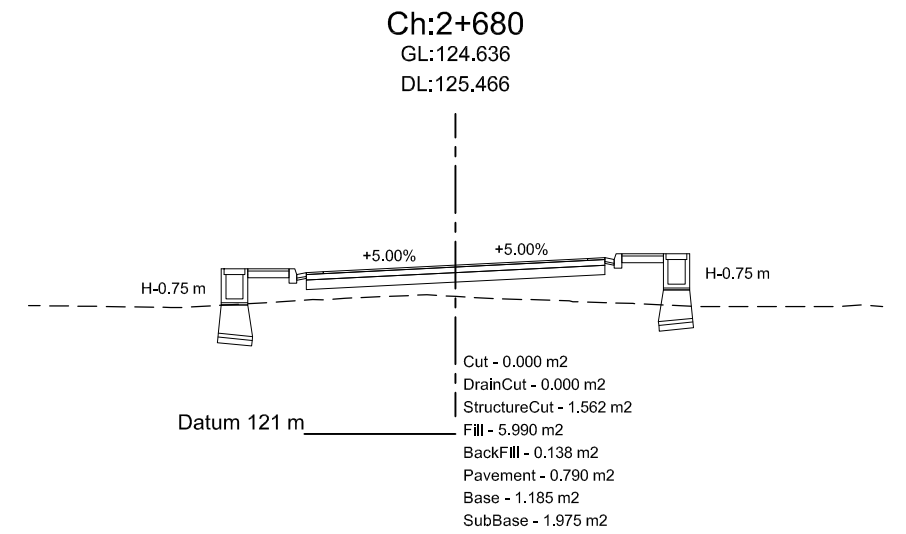
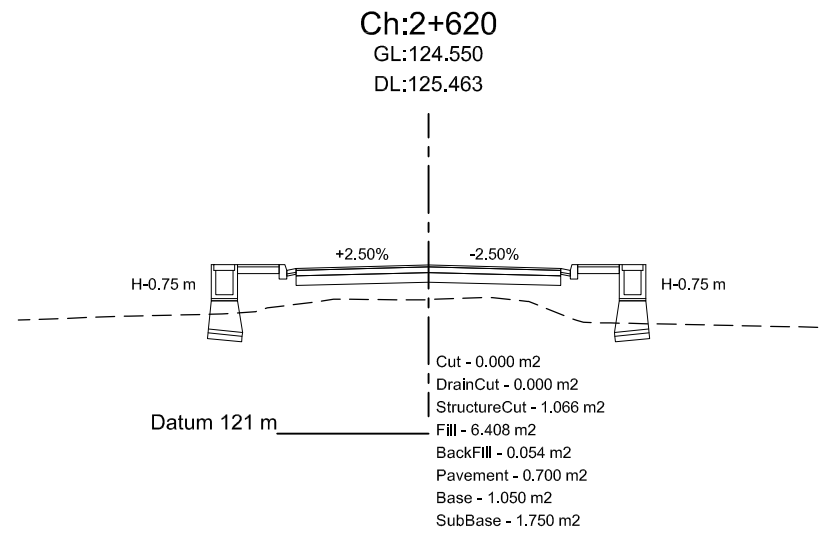
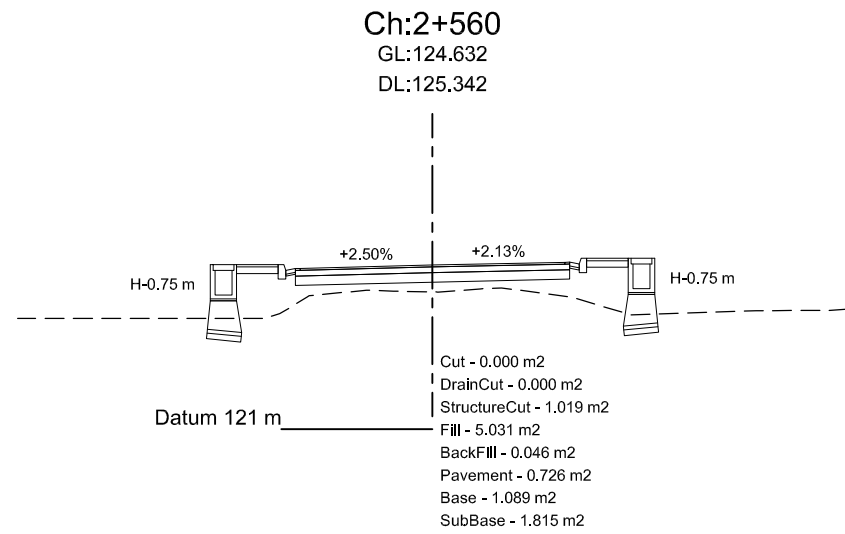

Department of Urban Development & Building
Construction (DUDBC)
Regional Urban Development Project (RUDP)
West Urban Corridor (WUC) Development Project
Babarmahal, Kathmandu, Nepal

Reviewed & Designed By :
DOHWA Engineering Co. Ltd.
in Association with
ERMIC (P.) Ltd., SILT Consultants (P.) Ltd., and
DIGICON (P.) Ltd.
Mid- Baneshwor, Kathmandu
Tel: 01- 4589393

Consultant
Team Leader : YOO CHANGMIN
Reviewed By : YAGYA BAHADUR MALLA
Designed By : MANJU MUNANKARMI

Client
Approved By :
Checked By :

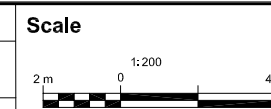

Cross-Section
BHALUHIPUL-MEDICAL COLLEGE-
BHATATOL-MUKHIYATOL-PIPARHIYA-
SINGHA-MUNICIPALITY
CH 0+000 - 7+503.82 Km

REV : MAY 2024
DRG NO : DM/RD/CS/16
CHAINAGE : 2+520-2+680
SHEET NO : 16

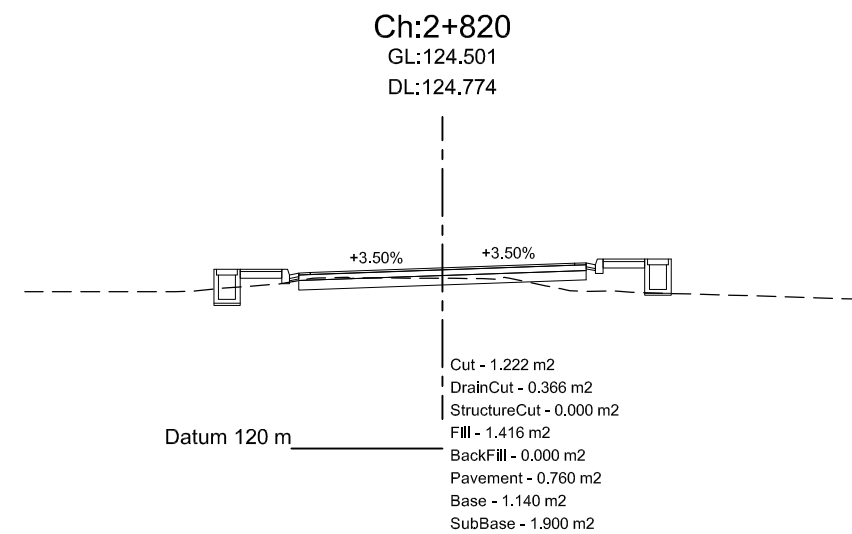
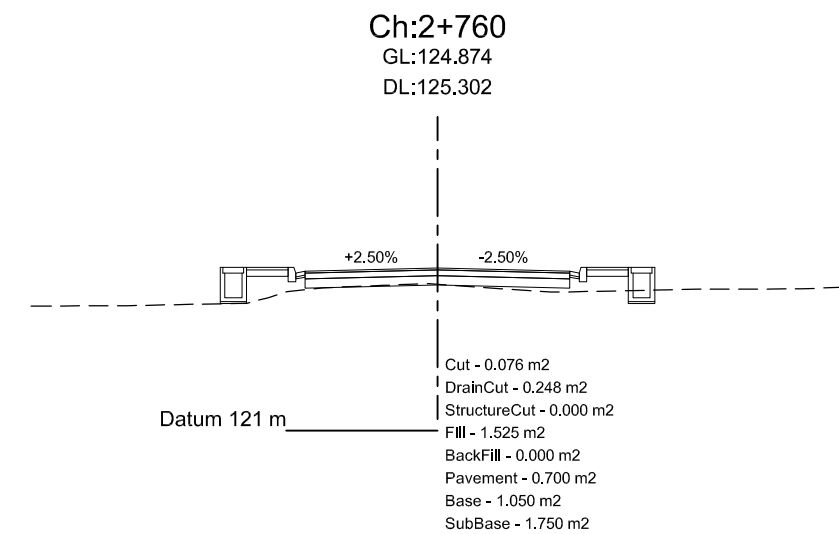
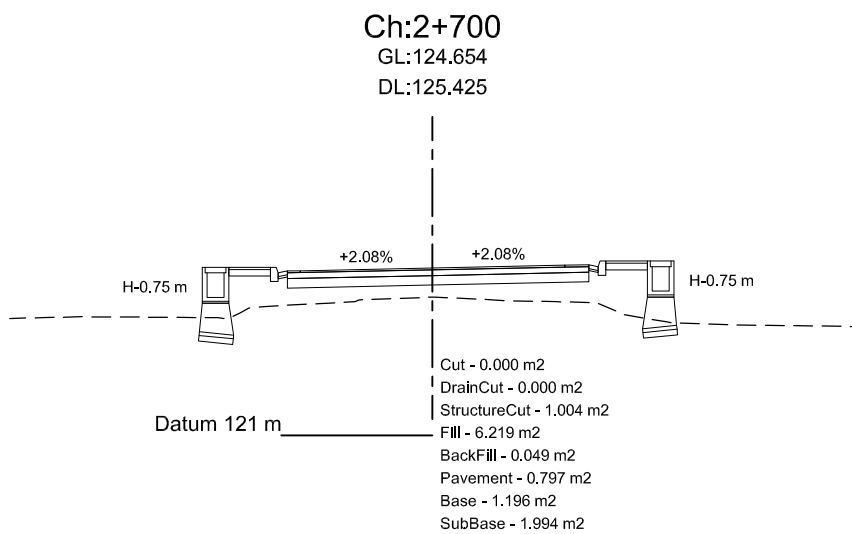
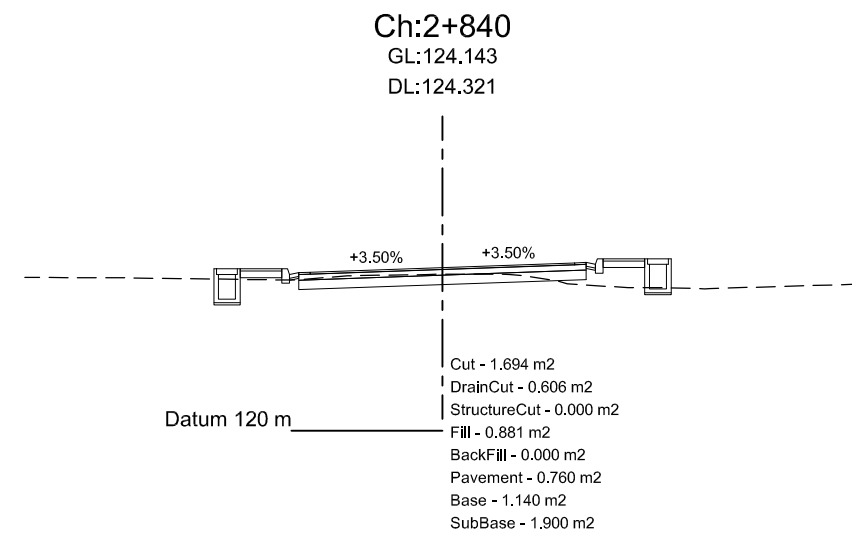
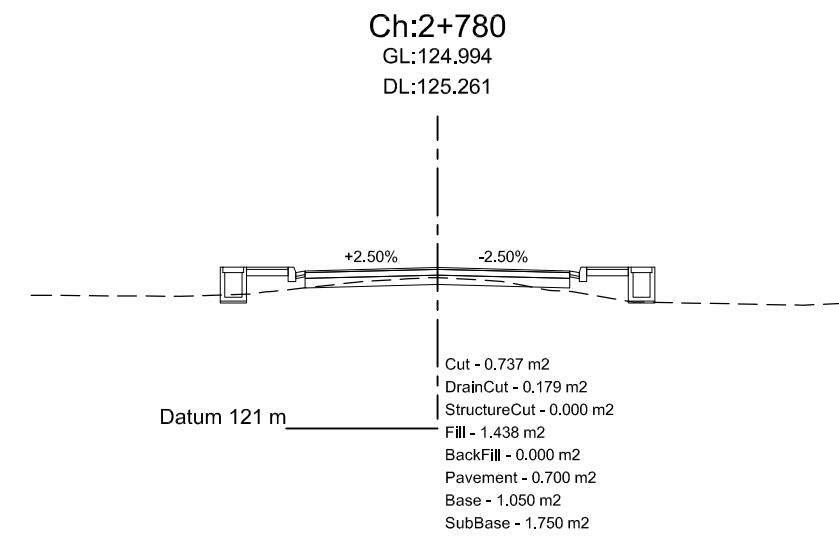
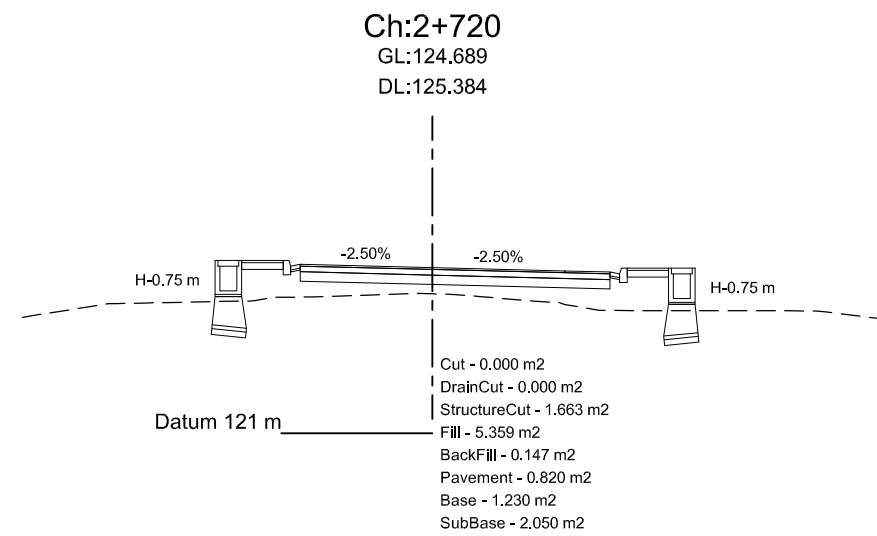
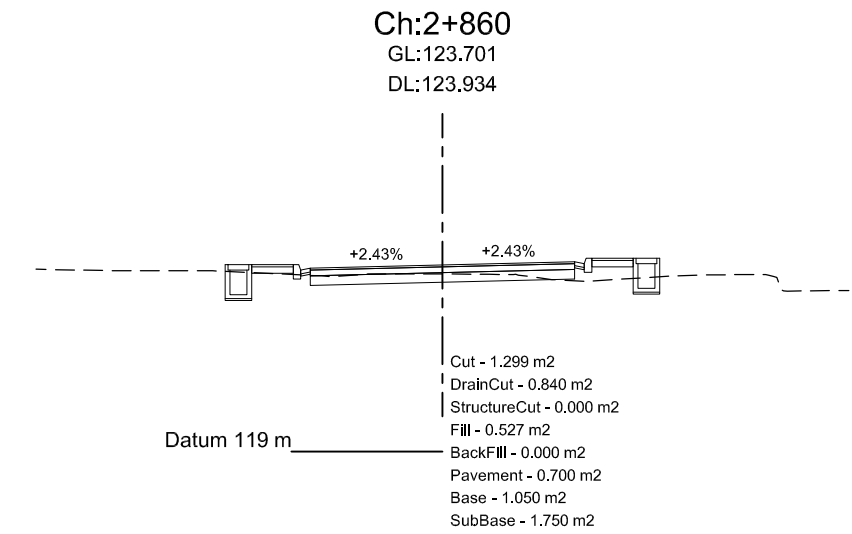
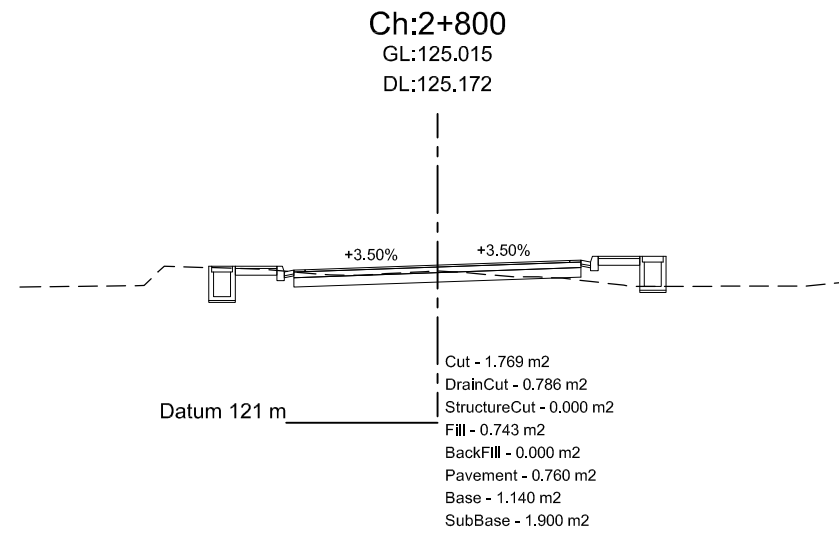
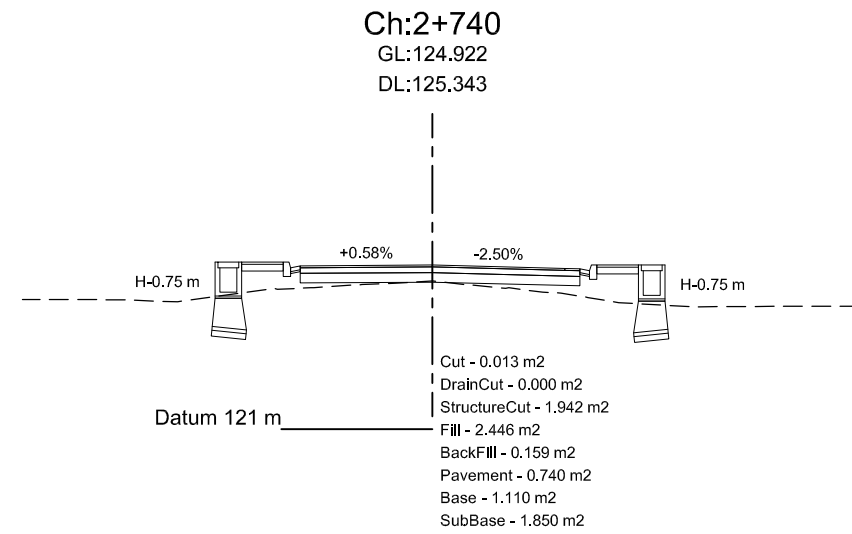

Department of Urban Development & Building
Construction (DUDBC)
Regional Urban Development Project (RUDP)
West Urban Corridor (WUC) Development Project
Babarmahal, Kathmandu, Nepal

Reviewed & Designed By :
DOHWA Engineering Co. Ltd.
in Association with
ERMIC (P.) Ltd., SILT Consultants (P.) Ltd., and
DIGICON (P.) Ltd.
Mid- Baneshwor, Kathmandu
Tel: 01- 4589393

Consultant
Team Leader : YOO CHANGMIN
Reviewed By : YAGYA BAHADUR MALLA
Designed By : MANJU MUNANKARMI

Client
Approved By :
Checked By :

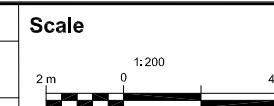

Cross-Section
BHALUHIPUL-MEDICAL COLLEGE-
BHATATOL-MUKHIYATOL-PIPARHIYA-
SINGHA-MUNICIPALITY
CH 0+000 - 7+503.82 Km

REV : MAY 2024
DRG NO : DM/RD/CS/17
CHAINAGE : 2+700-2+860
SHEET NO : 17

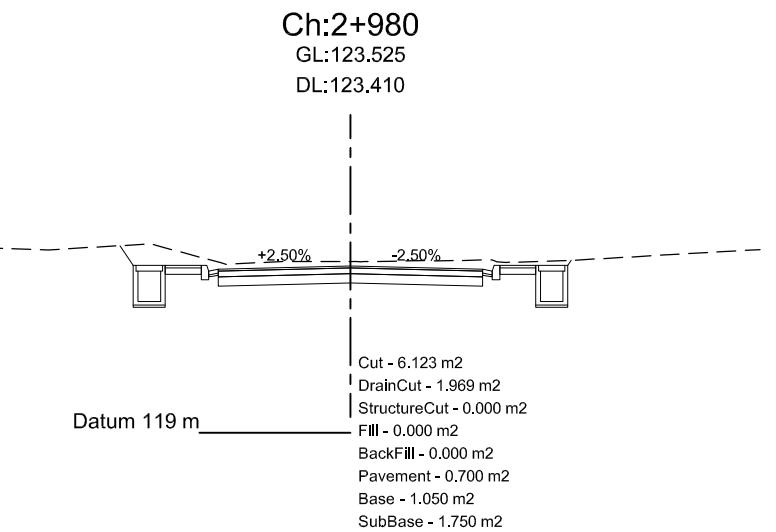
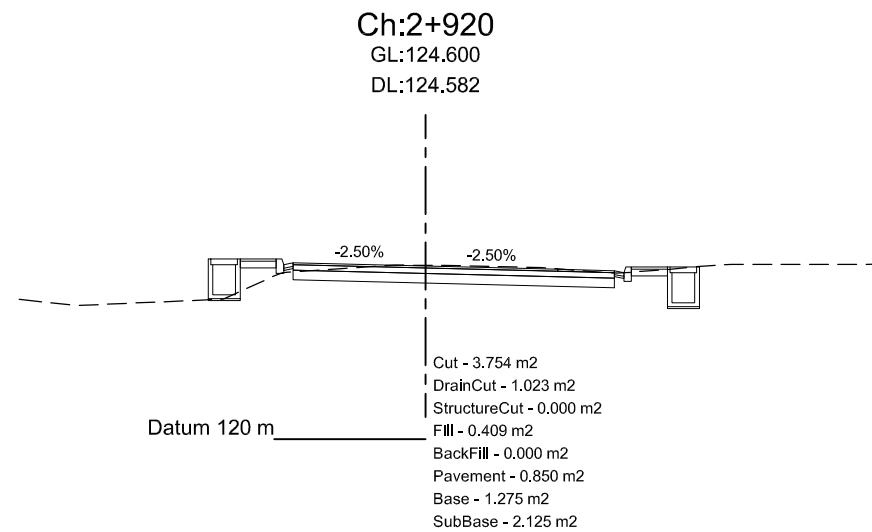
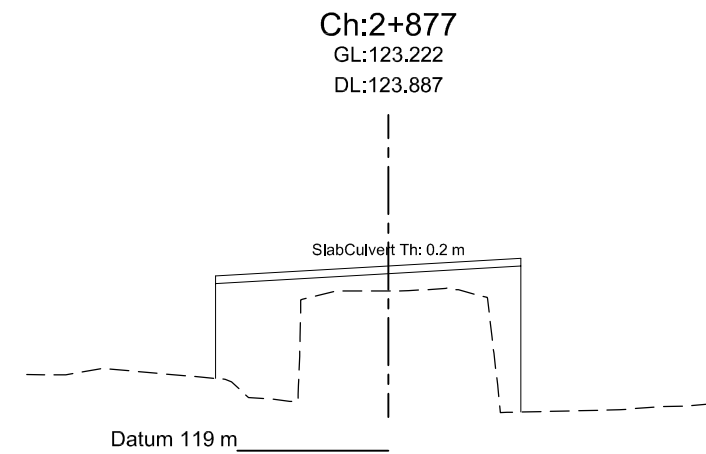
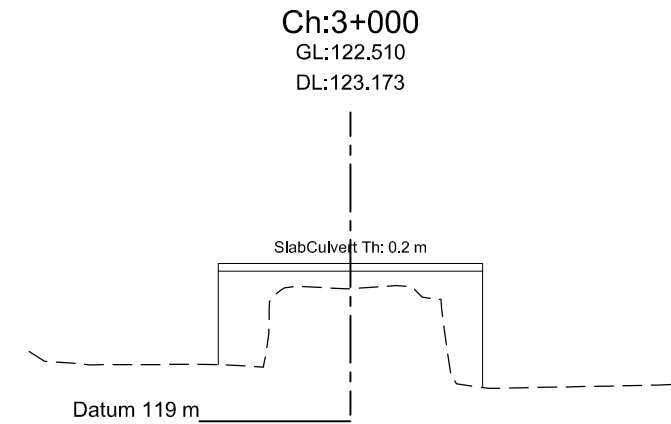
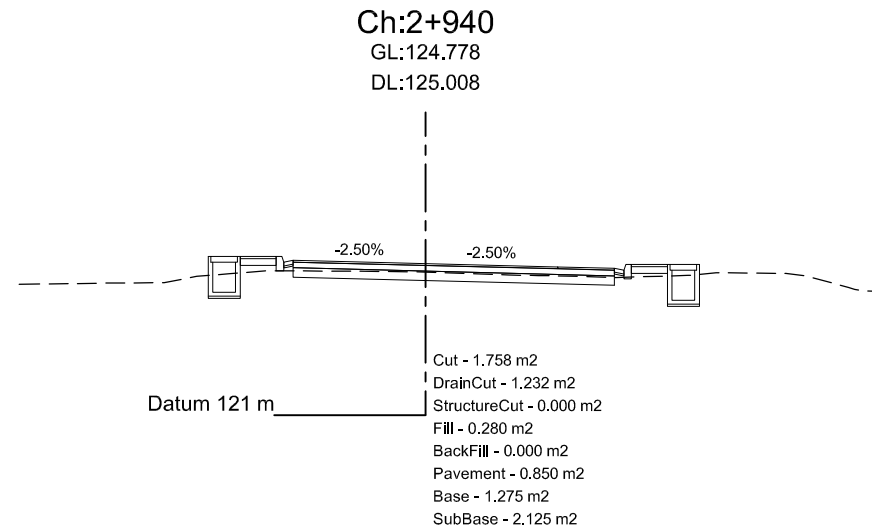
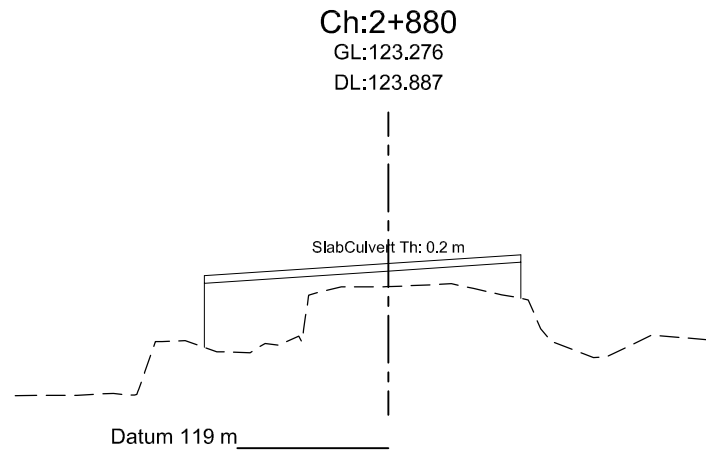
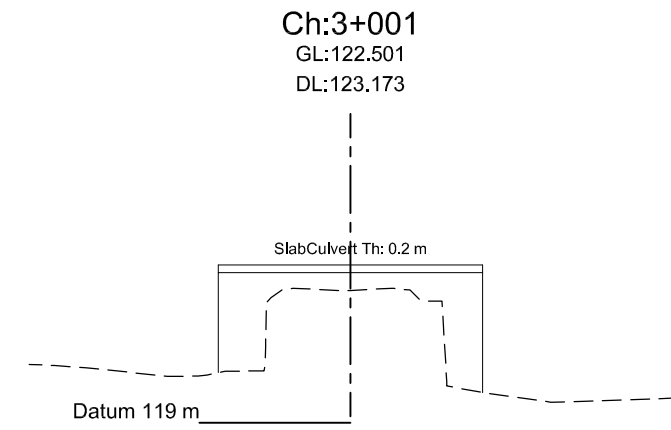
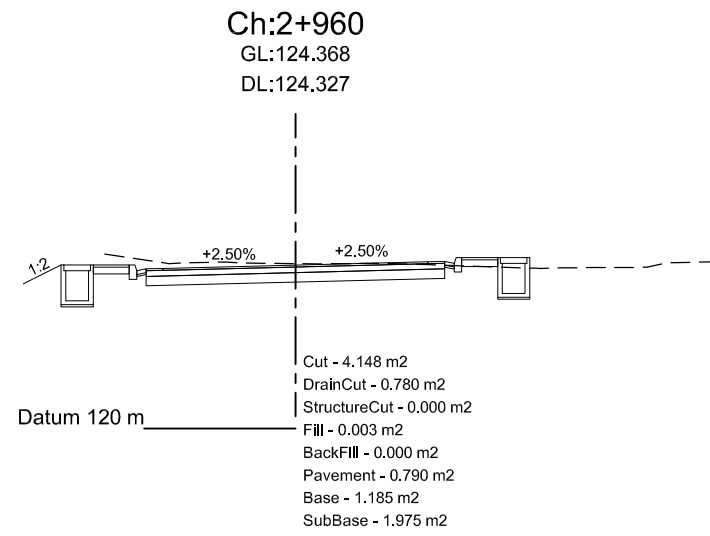
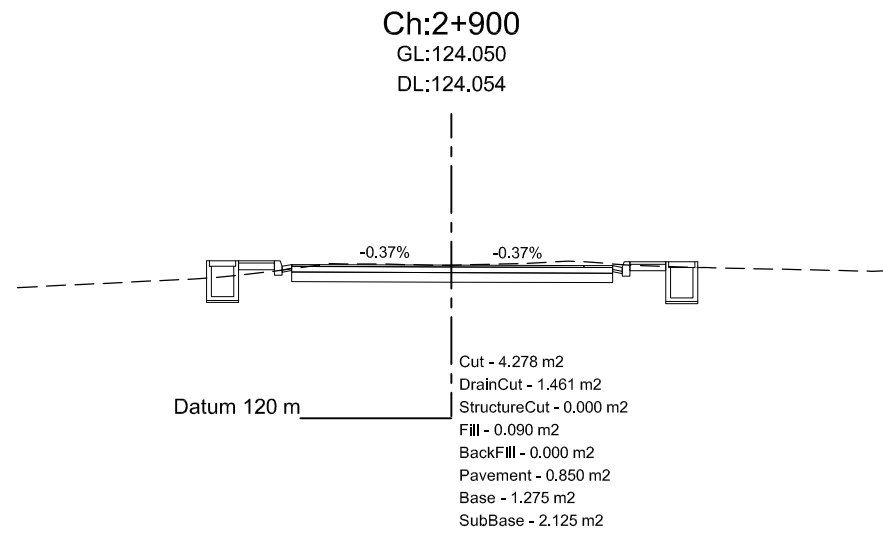

Department of Urban Development & Building
Construction (DUDBC)
Regional Urban Development Project (RUDP)
West Urban Corridor (WUC) Development Project
Babarmahal, Kathmandu, Nepal

Reviewed & Designed By :
DOHWA Engineering Co. Ltd.
in Association with
ERMIC (P.) Ltd., SILT Consultants (P.) Ltd., and
DIGICON (P.) Ltd.
Mid- Baneshwor, Kathmandu
Tel: 01- 4589393

Consultant
Team Leader : YOO CHANGMIN
Reviewed By : YAGYA BAHADUR MALLA
Designed By : MANJU MUNANKARMI

Client
Approved By :
Checked By :

Scale



Cross-Section
BHALUHIPUL-MEDICAL COLLEGE-
BHATATOL-MUKHIYATOL-PIPARHIYA-
SINGHA-MUNICIPALITY
CH 0+000 - 7+503.82 Km

REV : MAY 2024
DRG NO : DM/RD/CS/18
CHAINAGE : 2+877-3+001
SHEET NO : 18

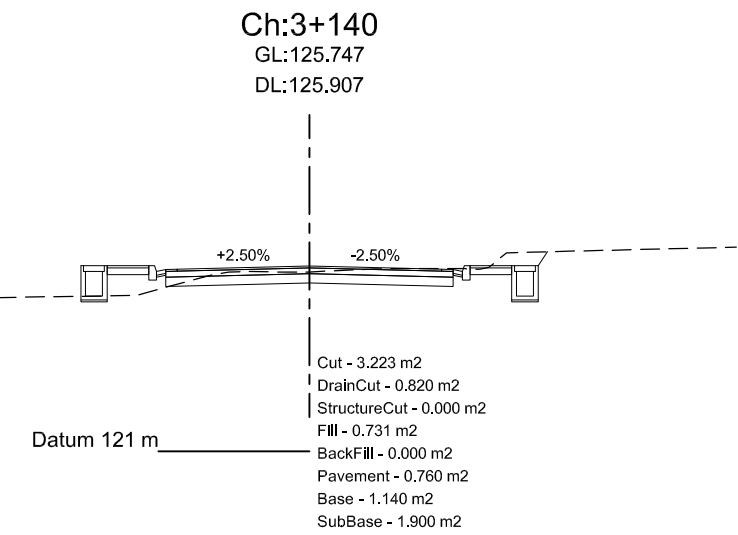
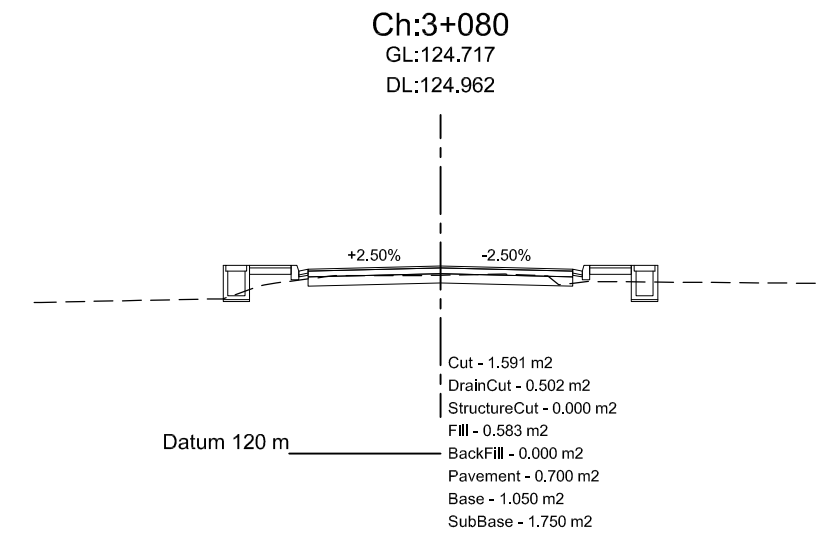
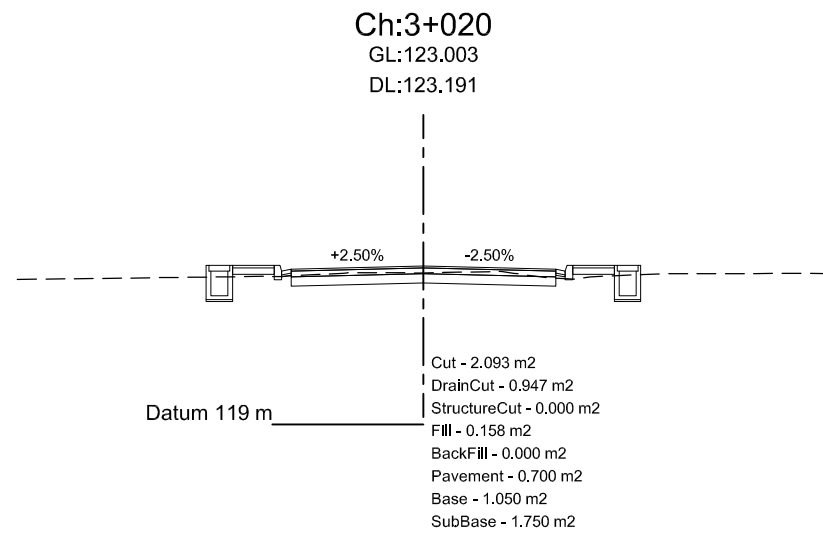
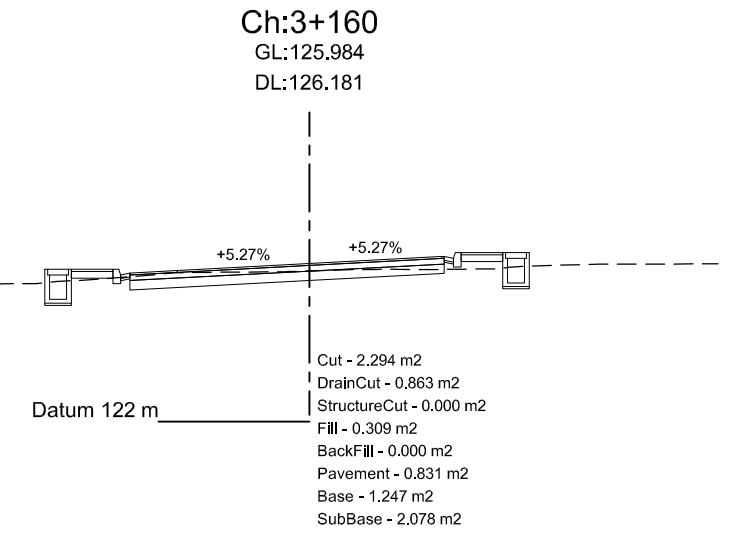
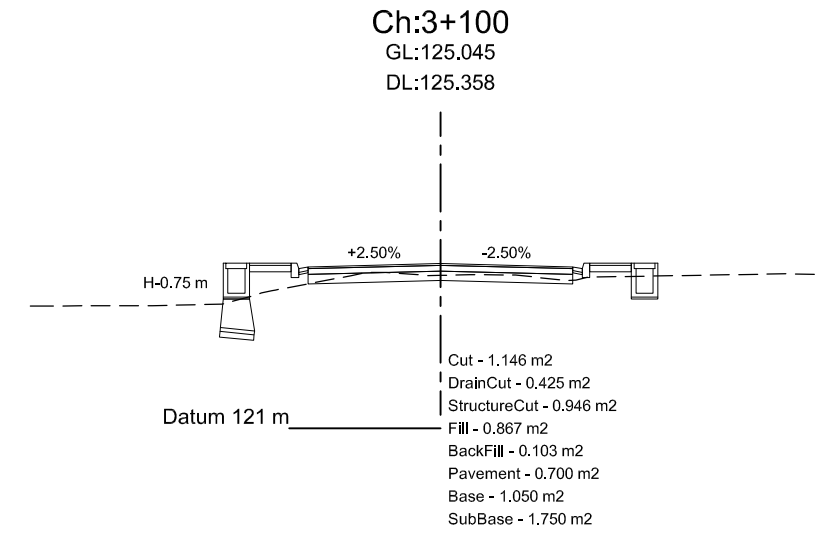
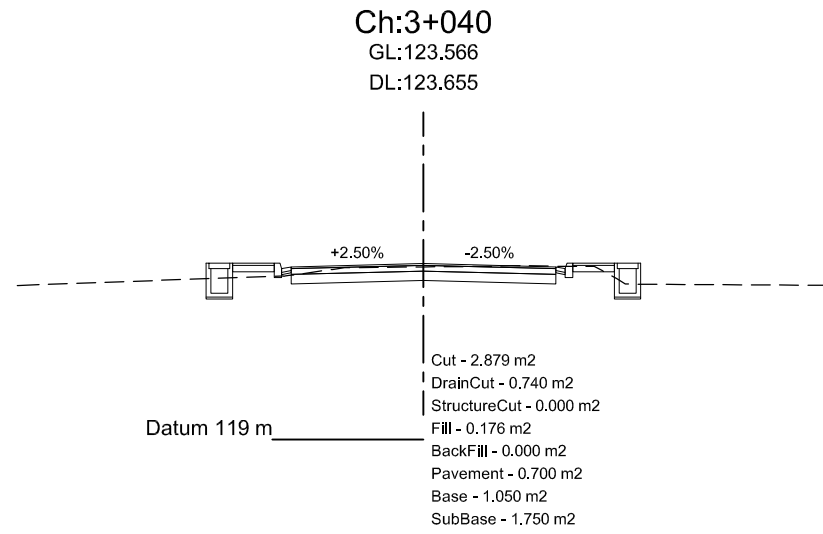
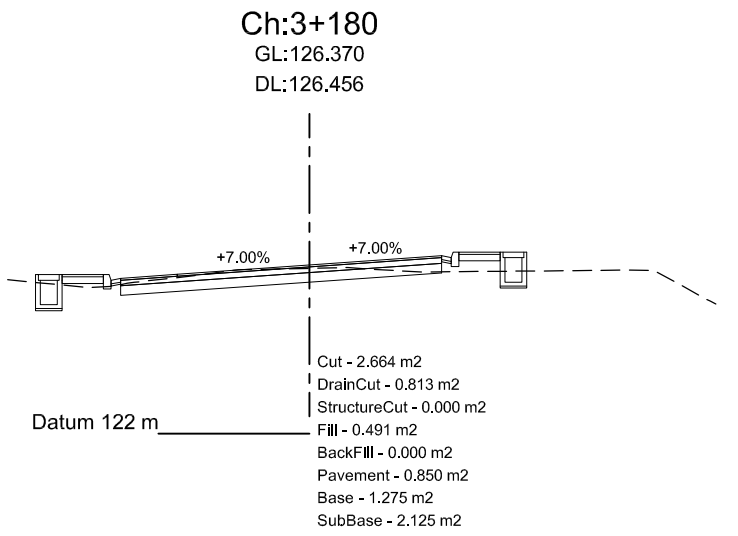
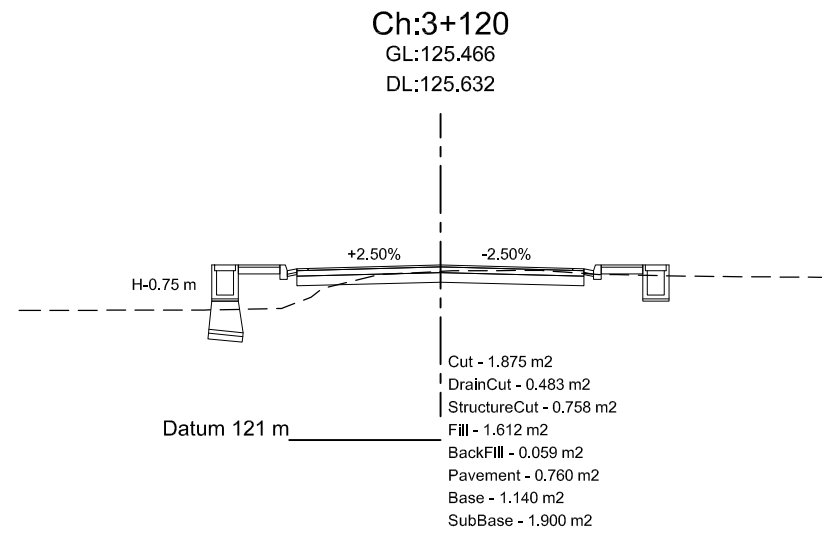
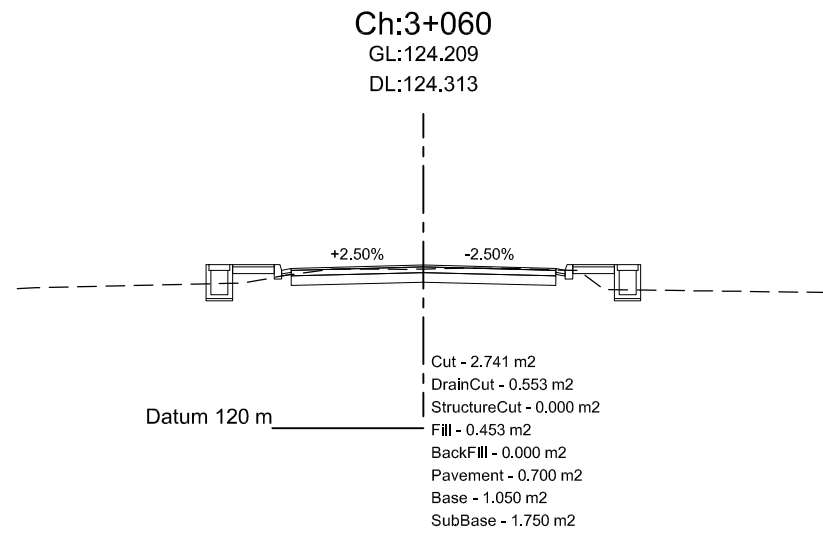

Department of Urban Development & Building
Construction (DUDBC)
Regional Urban Development Project (RUDP)
West Urban Corridor (WUC) Development Project
Babarmahal, Kathmandu, Nepal

Reviewed & Designed By :
DOHWA Engineering Co. Ltd.
in Association with
ERMIC (P.) Ltd., SILT Consultants (P.) Ltd., and
DIGICON (P.) Ltd.
Mid-Baneshwor, Kathmandu
Tel: 01-4589393

Consultant
Team Leader : YOO CHANGMIN
Reviewed By : YAGYA BAHADUR MALLA
Designed By : MANJU MUNANKARMI

Client
Approved By :
Checked By :

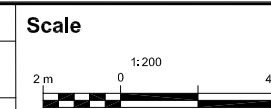

Cross-Section
BHALUHIPUL-MEDICAL COLLEGE-
BHATATOL-MUKHIYATOL-PIPARHIYA-
SINGHA-MUNICIPALITY
CH 0+000 - 7+503.82 Km

REV : MAY 2024
DRG NO : DM/RD/CS/19
CHAINAGE : 3+020-3+180
SHEET NO : 19

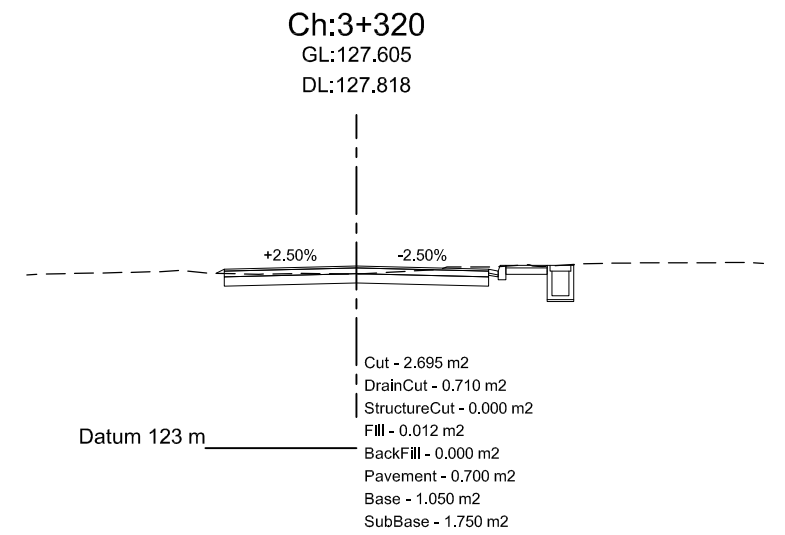
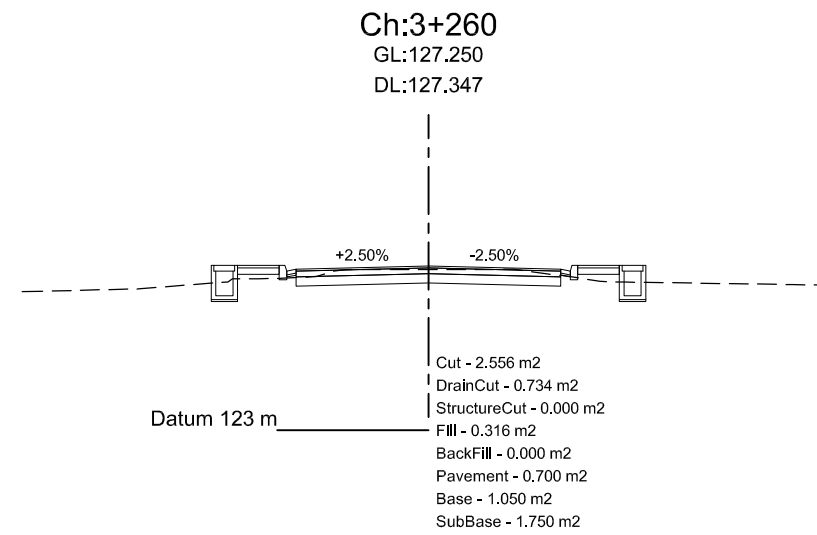
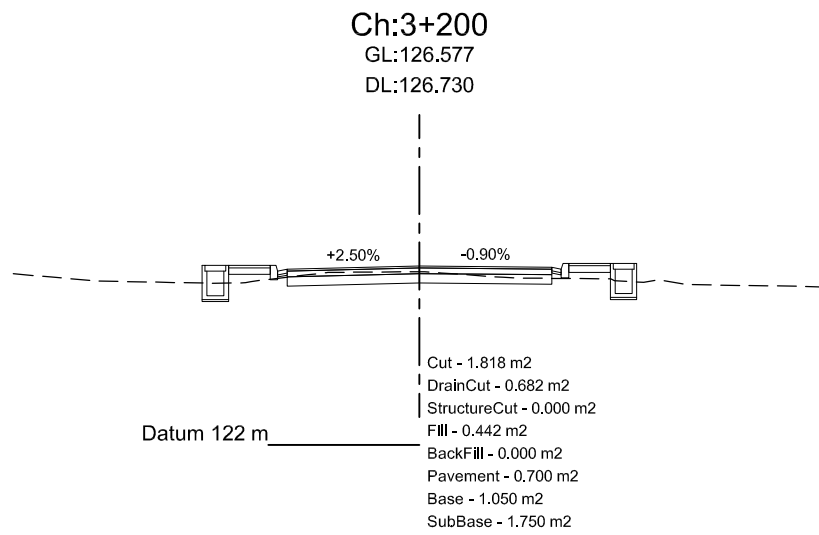
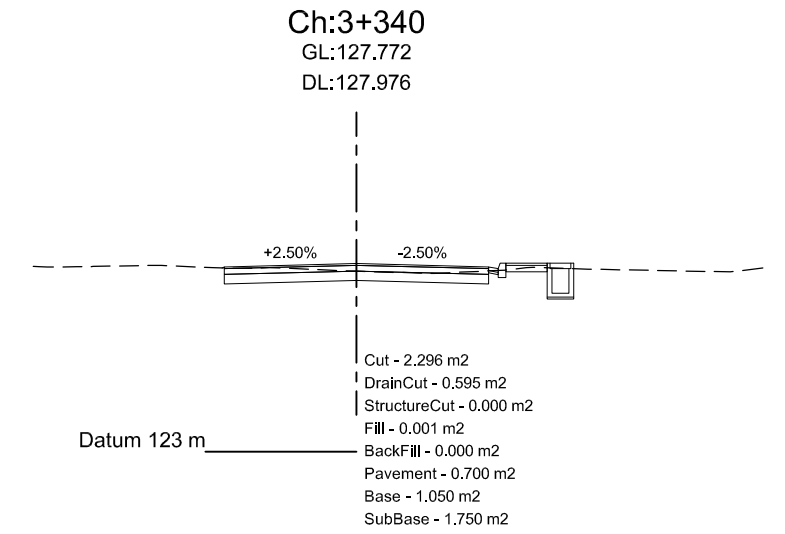
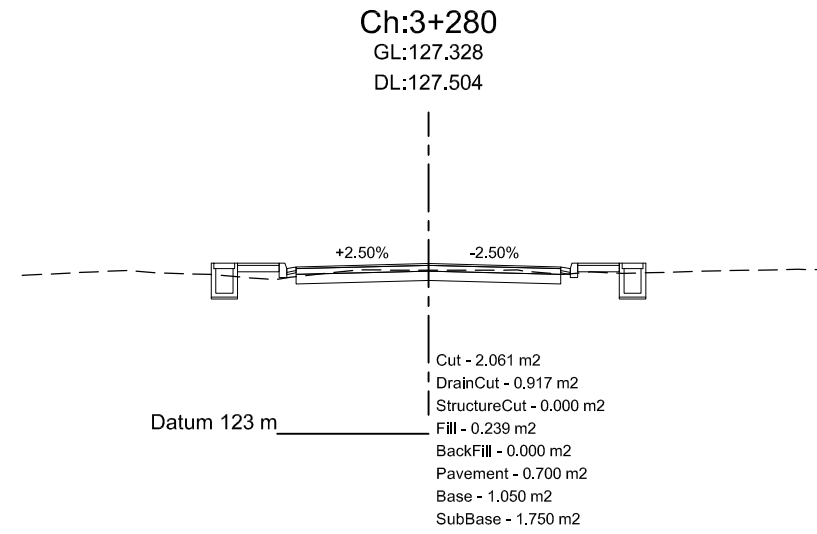
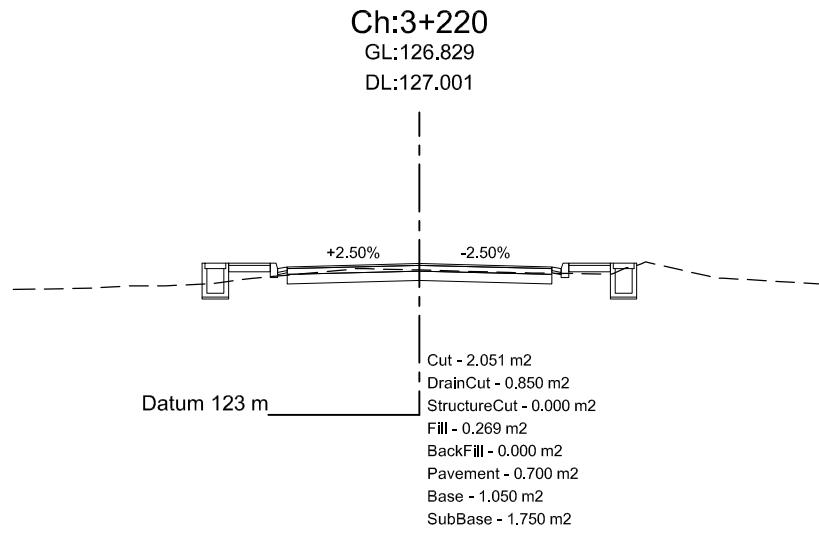
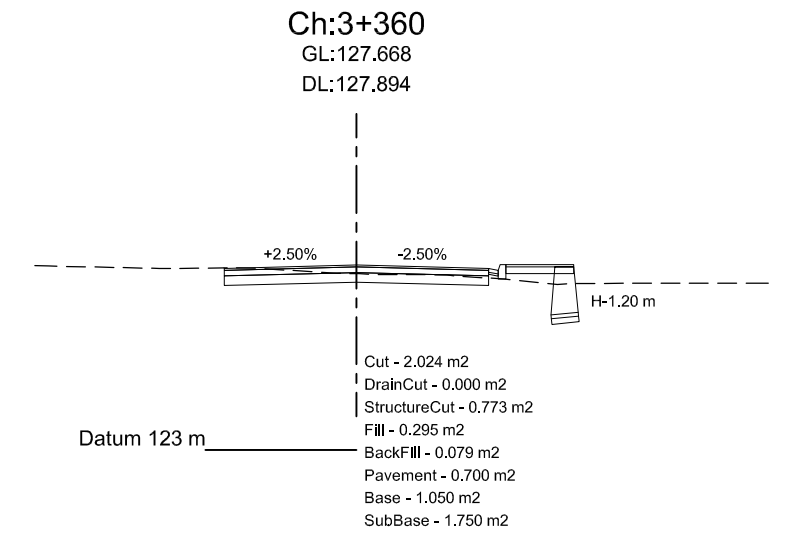
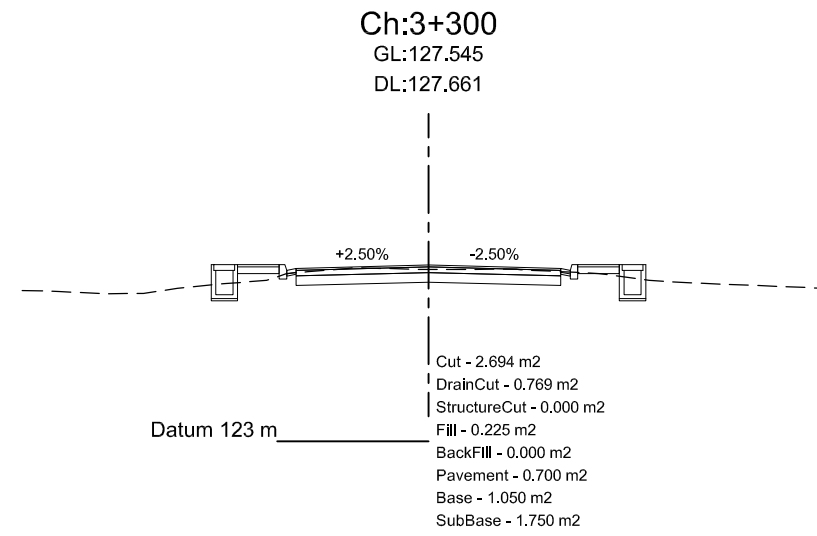
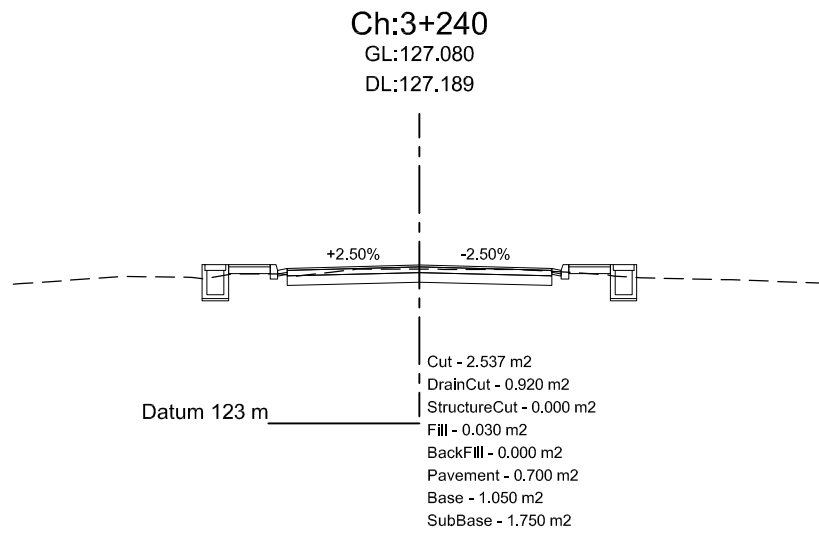

Department of Urban Development & Building
Construction (DUDBC)
Regional Urban Development Project (RUDP)
West Urban Corridor (WUC) Development Project
Babarmahal, Kathmandu, Nepal

Reviewed & Designed By :
DOHWA Engineering Co. Ltd.
in Association with
ERMIC (P.) Ltd., SILT Consultants (P.) Ltd., and
DIGICON (P.) Ltd.
Mid-Baneshwor, Kathmandu
Tel: 01-4589393

Consultant
Team Leader : YOO CHANGMIN
Reviewed By : YAGYA BAHADUR MALLA
Designed By : MANJU MUNANKARMI

Client
Approved By :
Checked By :

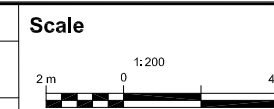

Cross-Section
BHALUHIPUL-MEDICAL COLLEGE-
BHATATOL-MUKHIYATOL-PIPARHIYA-
SINGHA-MUNICIPALITY
CH 0+000 - 7+503.82 Km

REV : MAY 2024
DRG NO : DM/RD/CS/20
CHAINAGE : 3+200-3+360
SHEET NO : 20

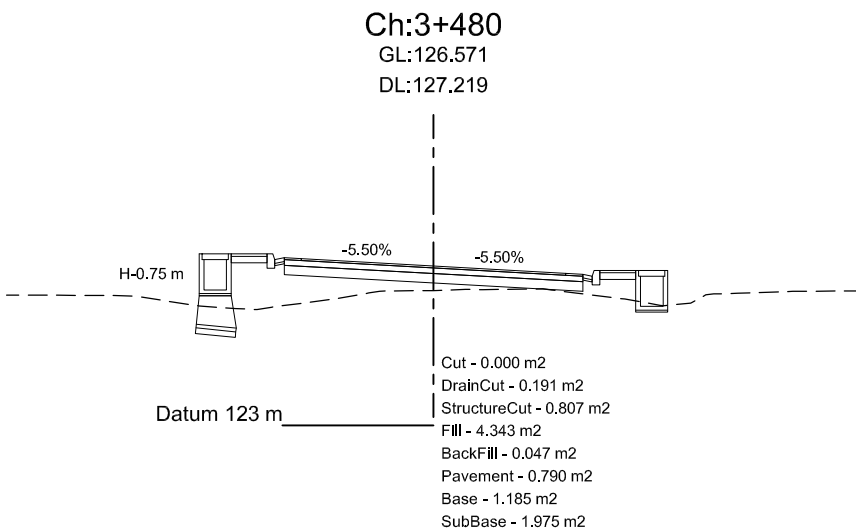
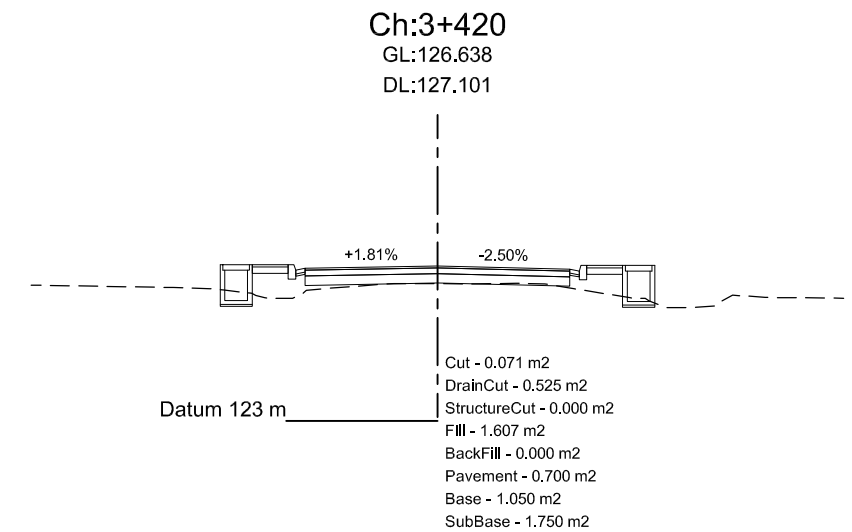
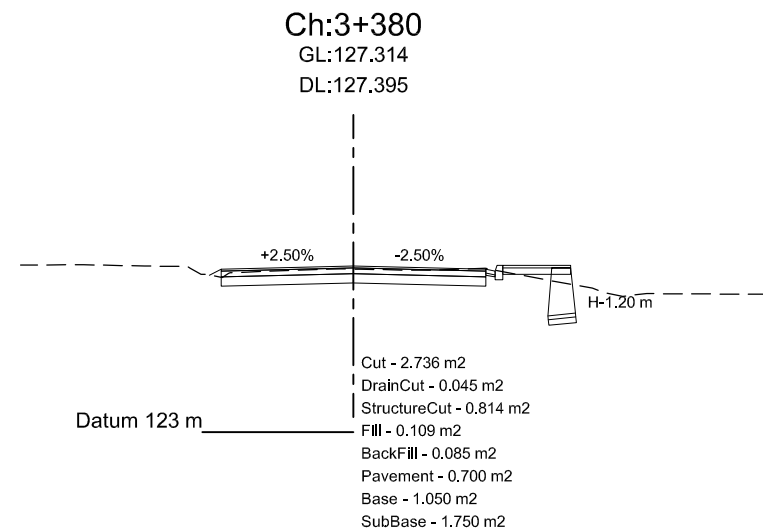
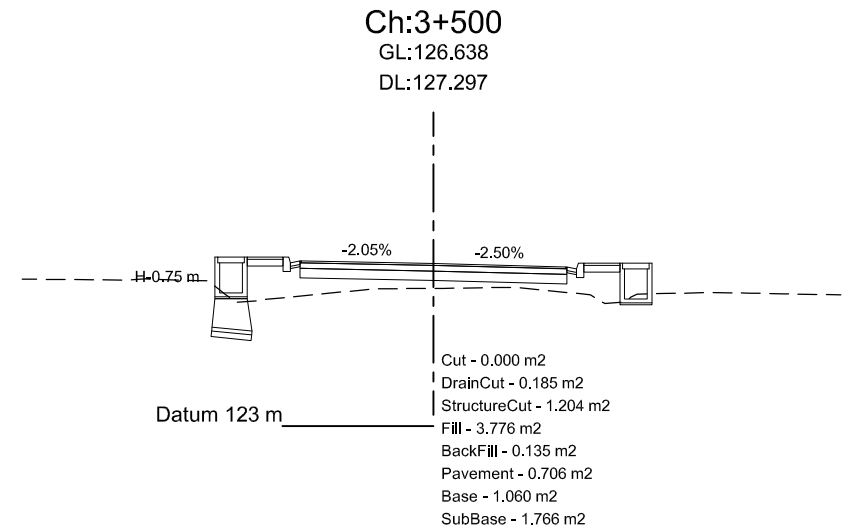
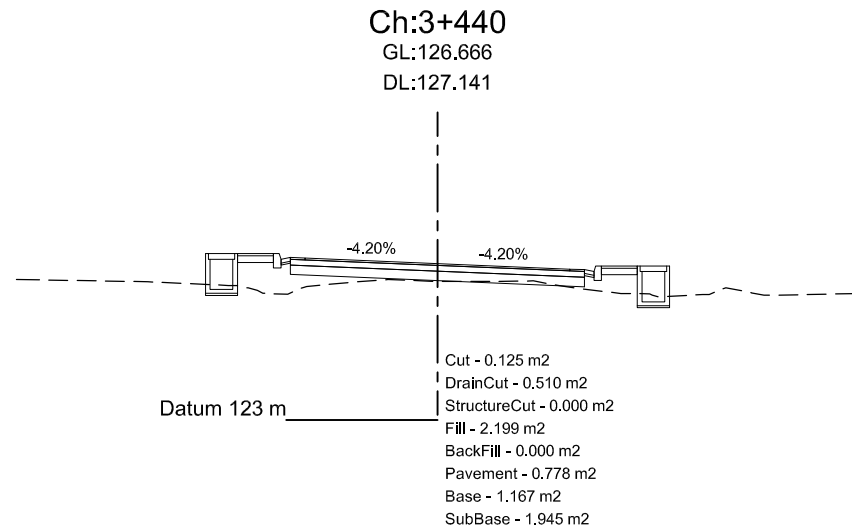
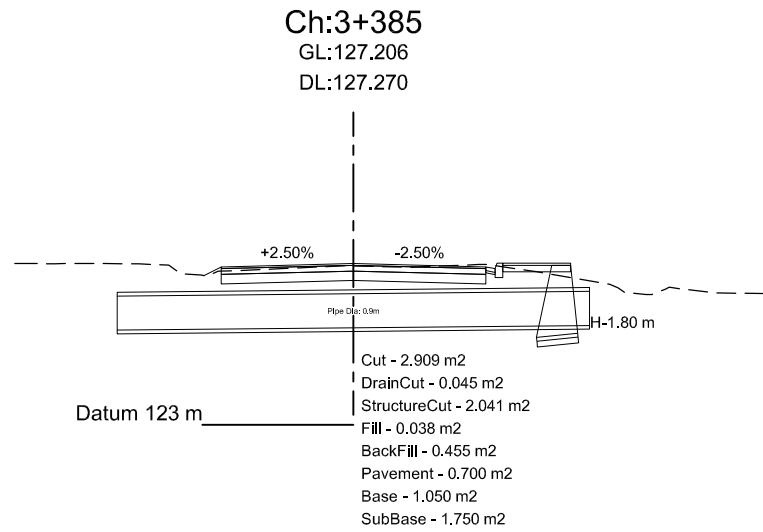
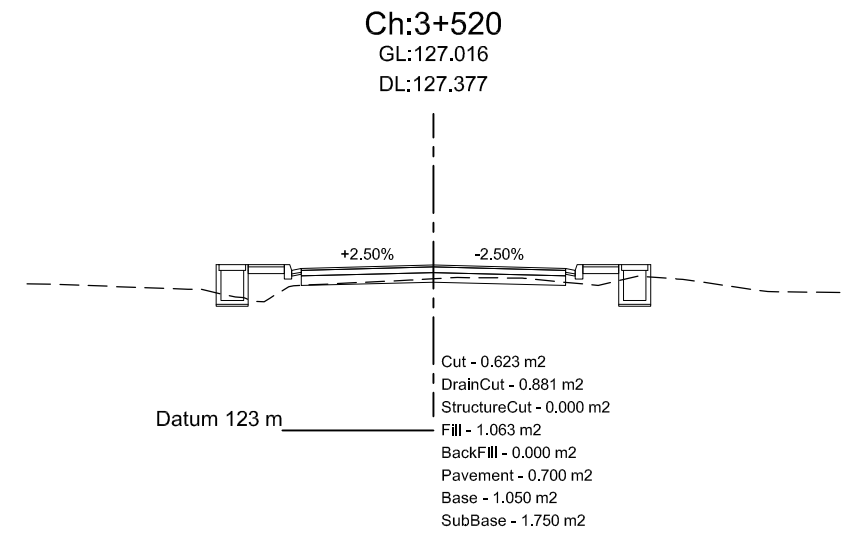
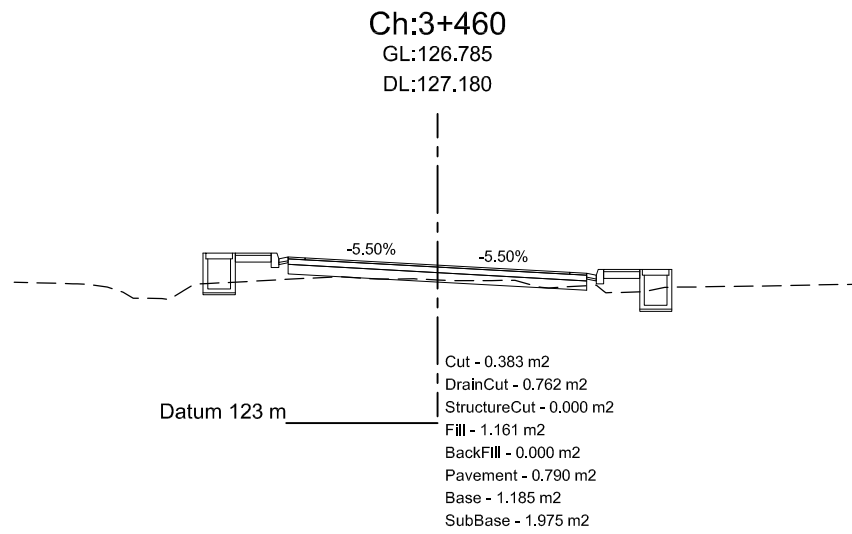
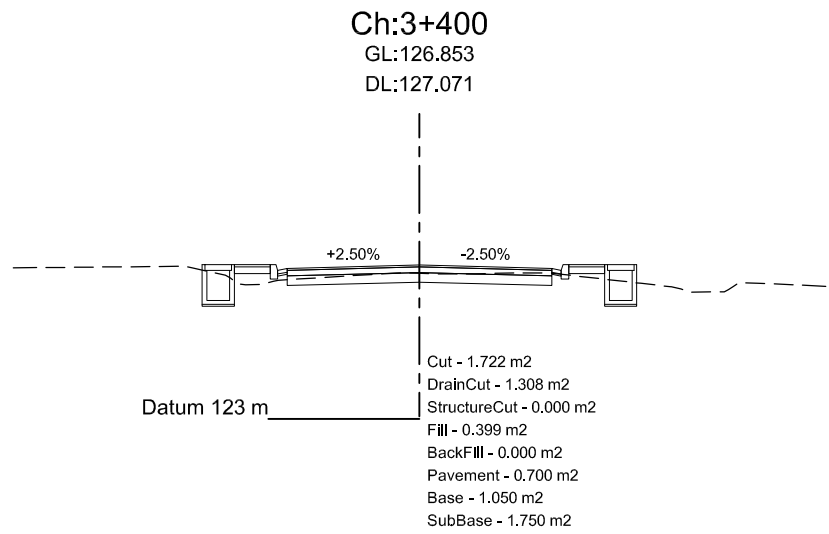

Department of Urban Development & Building
Construction (DUDBC)
Regional Urban Development Project (RUDP)
West Urban Corridor (WUC) Development Project
Babarmahal, Kathmandu, Nepal

Reviewed & Designed By :
DOHWA Engineering Co. Ltd.
in Association with
ERMIC (P.) Ltd., SILT Consultants (P.) Ltd., and
DIGICON (P.) Ltd.
Mid- Baneshwor, Kathmandu
Tel: 01- 4589393

Consultant
Team Leader : YOO CHANGMIN
Reviewed By : YAGYA BAHADUR MALLA
Designed By : MANJU MUNANKARMI

Client
Approved By :
Checked By :

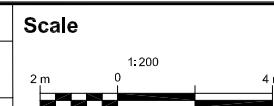

Cross-Section
BHALUHIPUL-MEDICAL COLLEGE-
BHATATOL-MUKHIYATOL-PIPARHIYA-
SINGHA-MUNICIPALITY
CH 0+000 - 7+503.82 Km

REV : MAY 2024
DRG NO : DM/RD/CS/21
CHAINAGE : 3+380-3+520
SHEET NO : 21

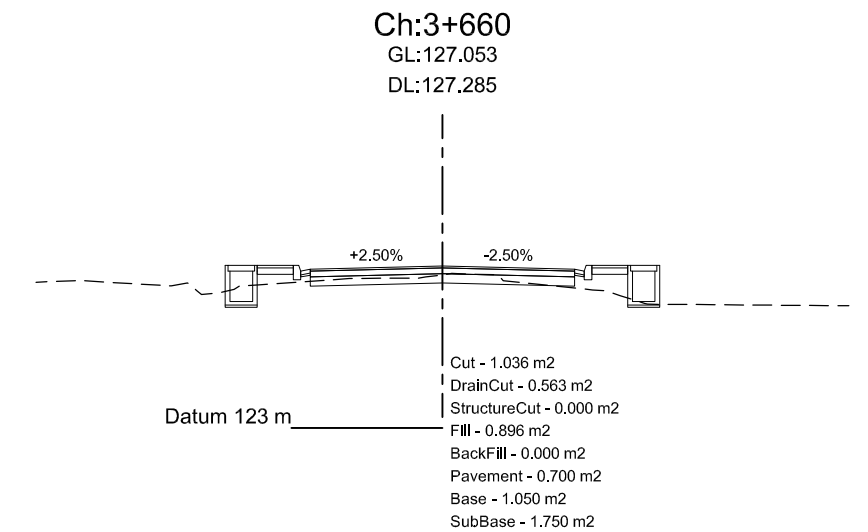
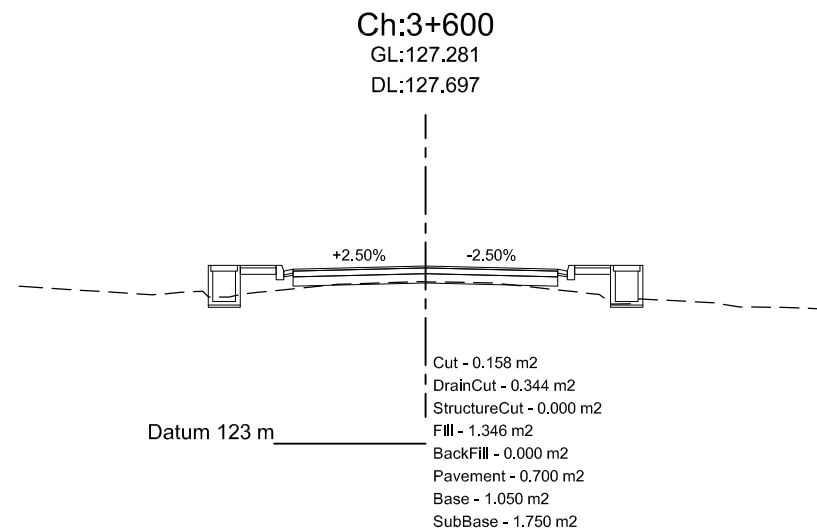
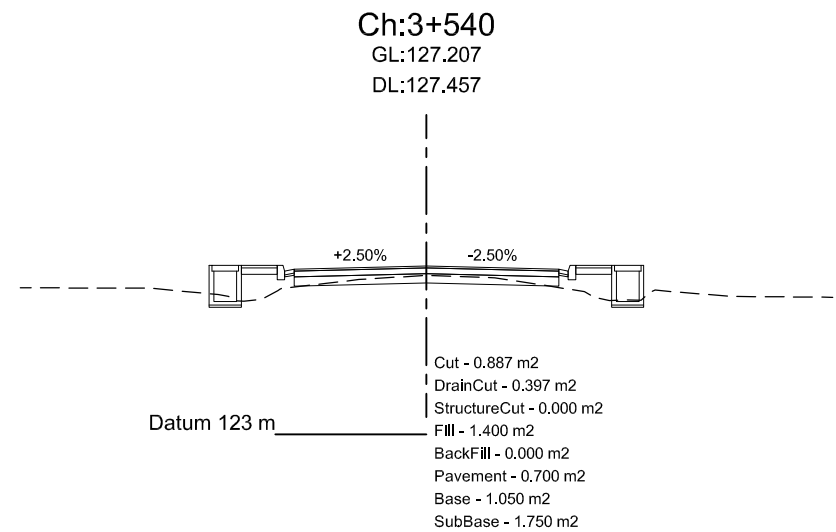
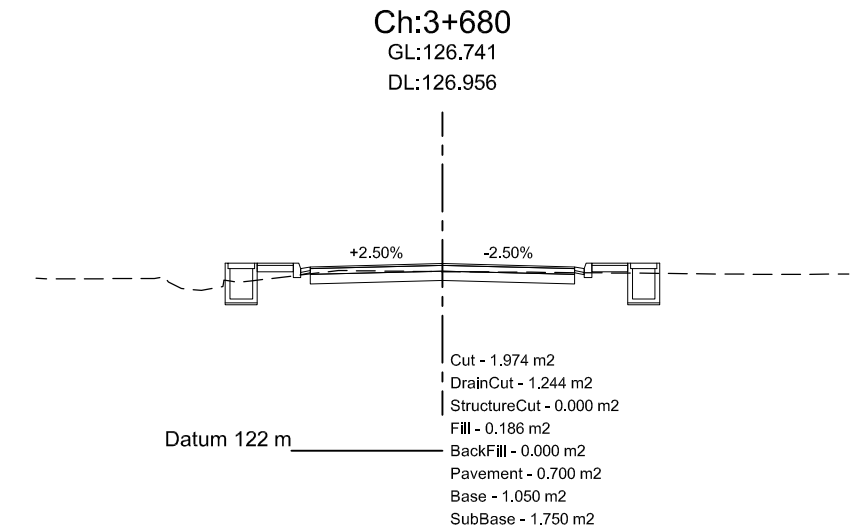
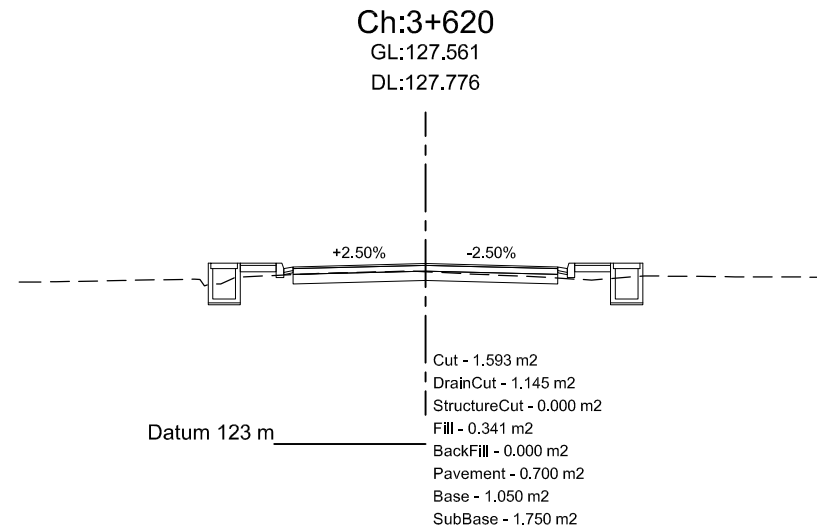
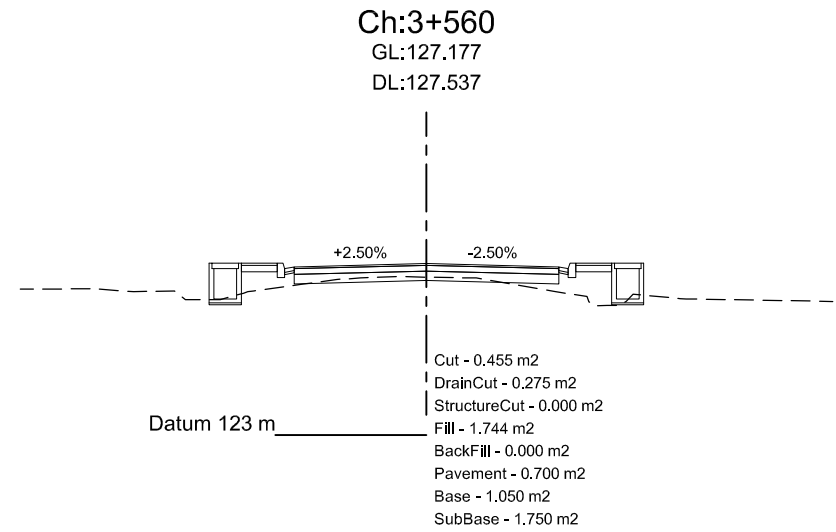
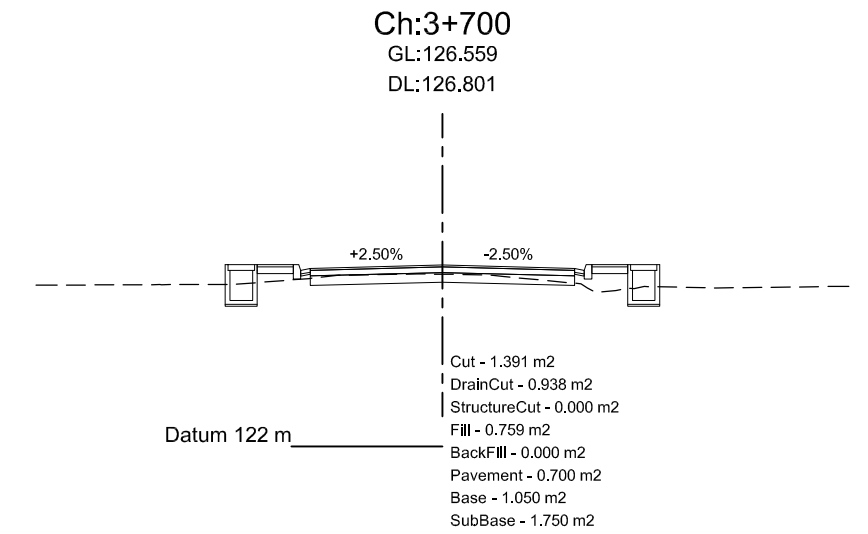
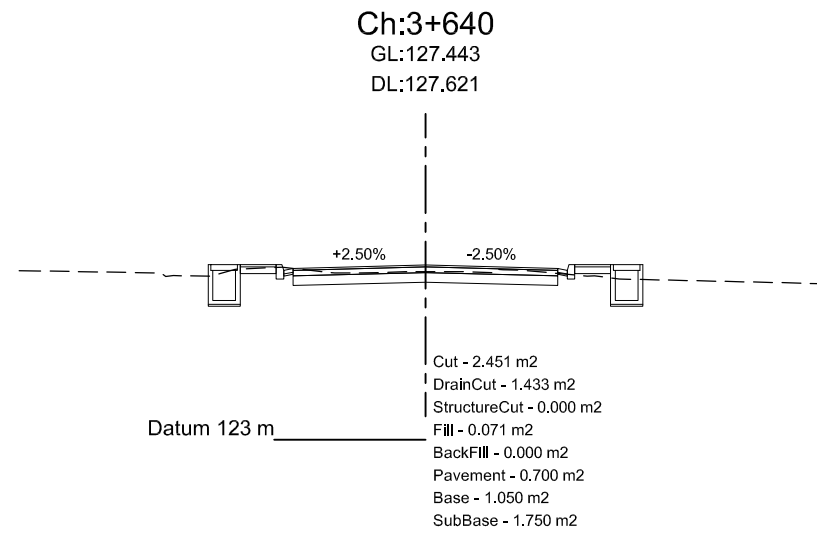
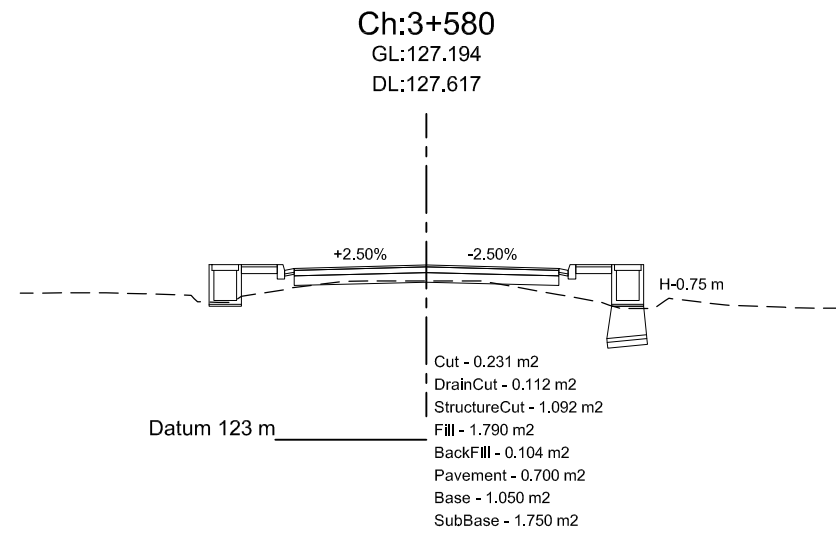

Department of Urban Development & Building
Construction (DUDBC)
Regional Urban Development Project (RUDP)
West Urban Corridor (WUC) Development Project
Babarmahal, Kathmandu, Nepal

Reviewed & Designed By :
DOHWA Engineering Co. Ltd.
in Association with
ERMIC (P.) Ltd., SILT Consultants (P.) Ltd., and
DIGICON (P.) Ltd.
Mid-Baneshwor, Kathmandu
Tel: 01-4589393

Consultant
Team Leader : YOO CHANGMIN
Reviewed By : YAGYA BAHADUR MALLA
Designed By : MANJU MUNANKARMI

Client
Approved By :
Checked By :

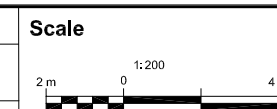

Cross-Section
BHALUHIPUL-MEDICAL COLLEGE-
BHATATOL-MUKHIYATOL-PIPARHIYA-
SINGHA-MUNICIPALITY
CH 0+000 - 7+503.82 Km

REV : MAY 2024
DRG NO : DM/RD/CS/22
CHAINAGE : 3+540-3+700
SHEET NO : 22

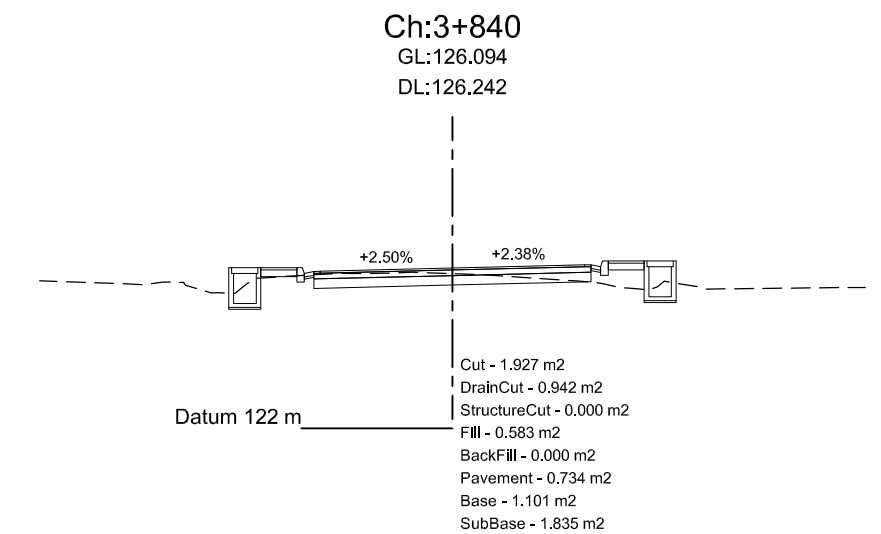
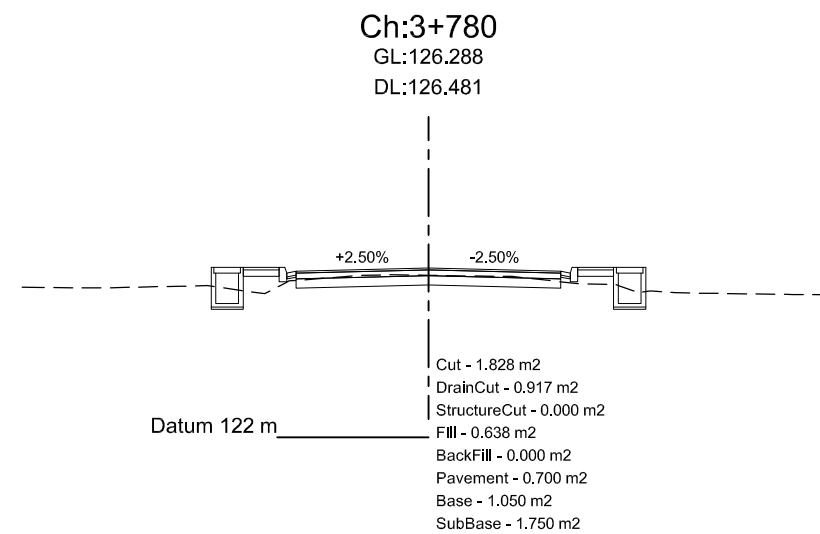
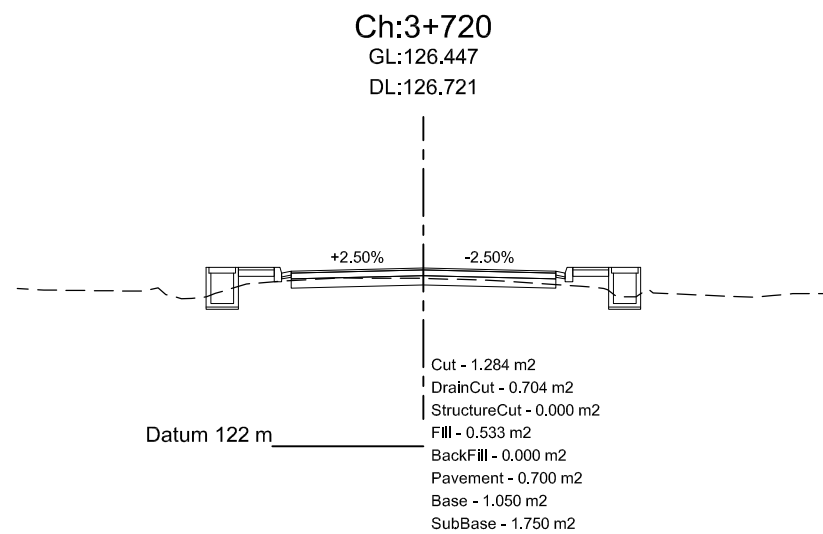
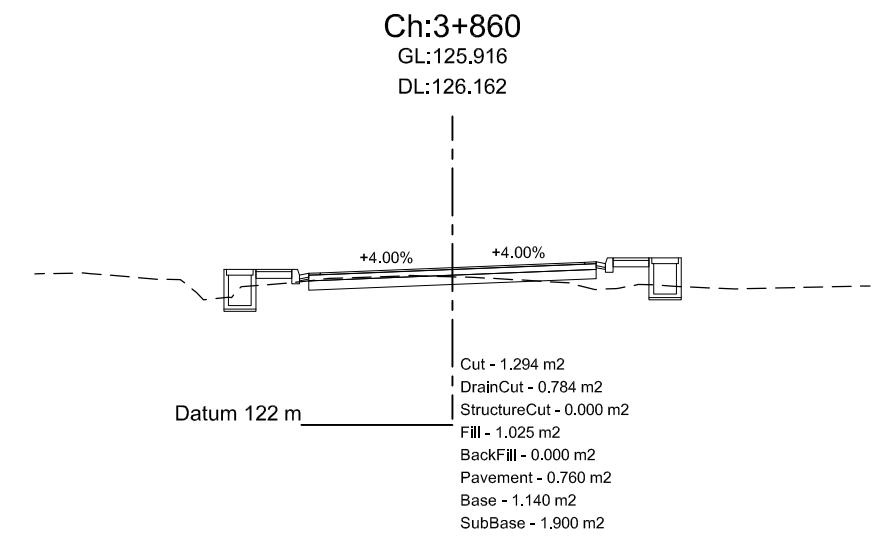
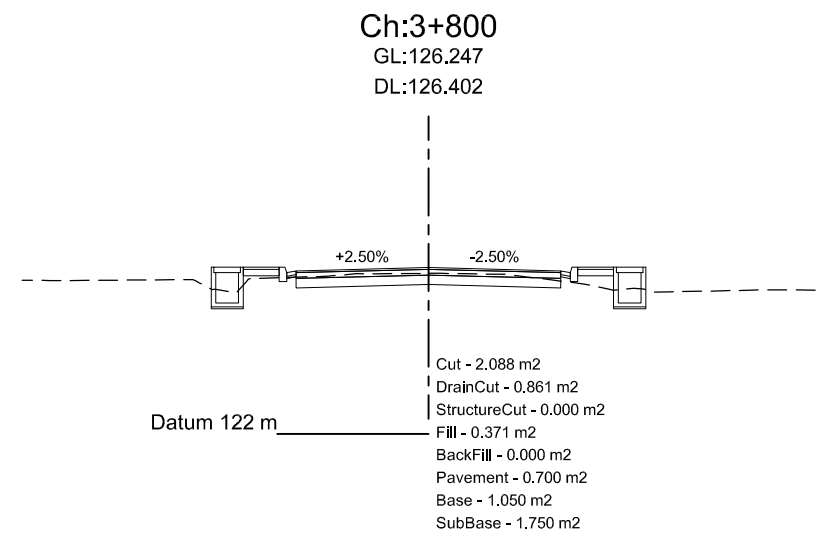
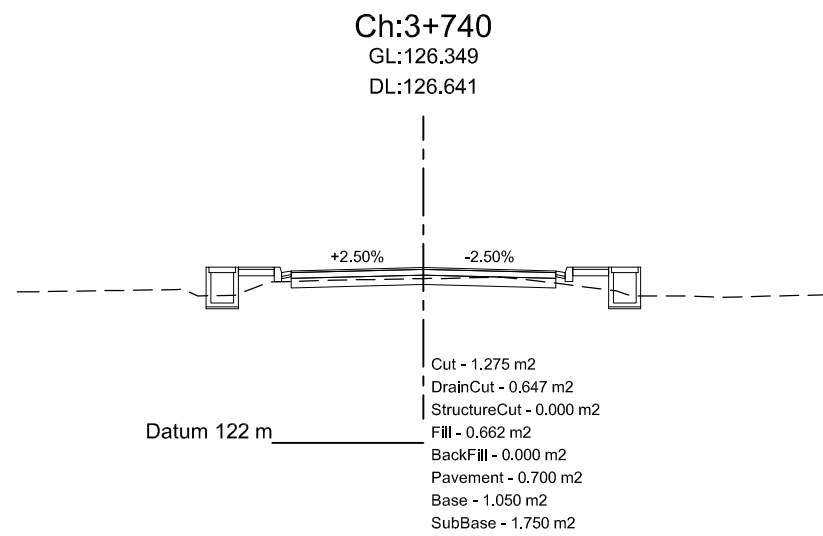
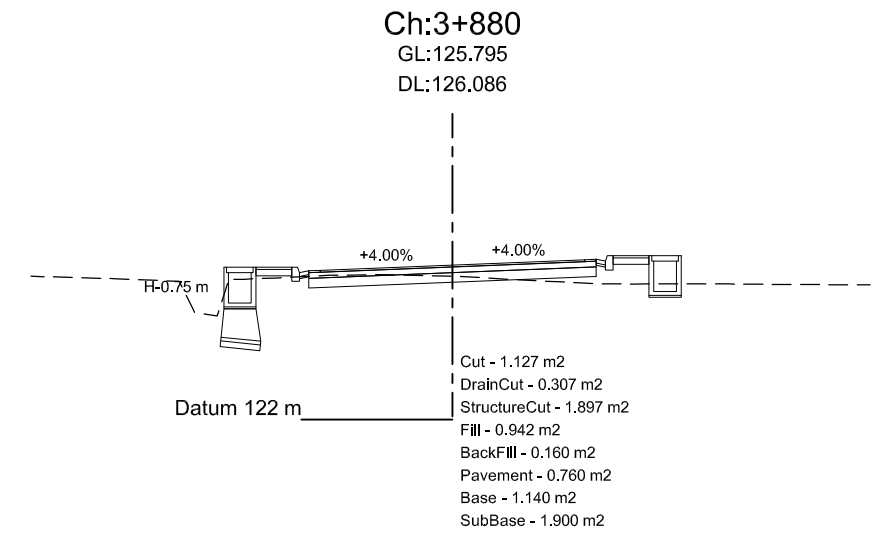
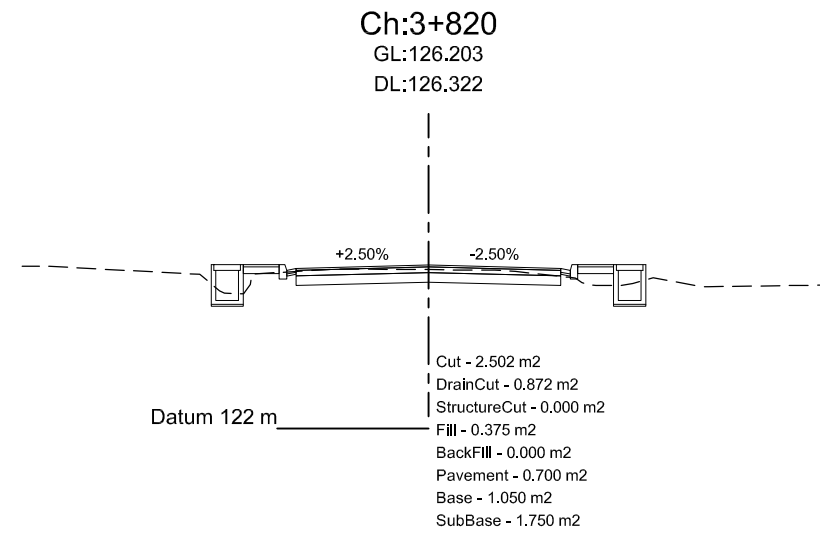
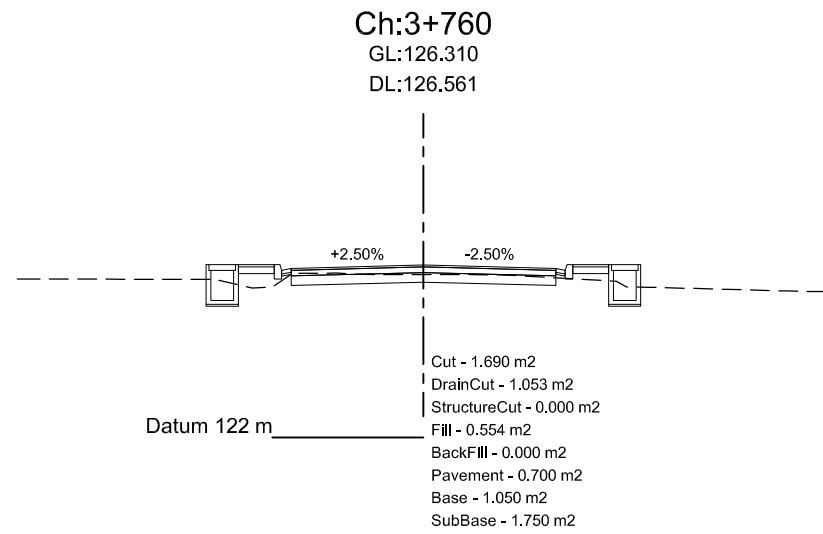

Department of Urban Development & Building
Construction (DUDBC)
Regional Urban Development Project (RUDP)
West Urban Corridor (WUC) Development Project
Babarmahal, Kathmandu, Nepal

Reviewed & Designed By :
DOHWA Engineering Co. Ltd.
in Association with
ERMIC (P.) Ltd., SILT Consultants (P.) Ltd., and
DIGICON (P.) Ltd.
Mid- Baneshwor, Kathmandu
Tel: 01- 4589393

Consultant
Team Leader : YOO CHANGMIN
Reviewed By : YAGYA BAHADUR MALLA
Designed By : MANJU MUNANKARMI

Client
Approved By :
Checked By :

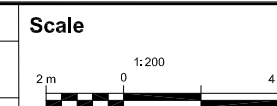

Cross-Section
BHALUHIPUL-MEDICAL COLLEGE-
BHATATOL-MUKHIYATOL-PIPARHIYA-
SINGHA-MUNICIPALITY
CH 0+000 - 7+503.82 Km

REV : MAY 2024
DRG NO : DM/RD/CS/23
CHAINAGE : 3+720-3+880
SHEET NO : 23

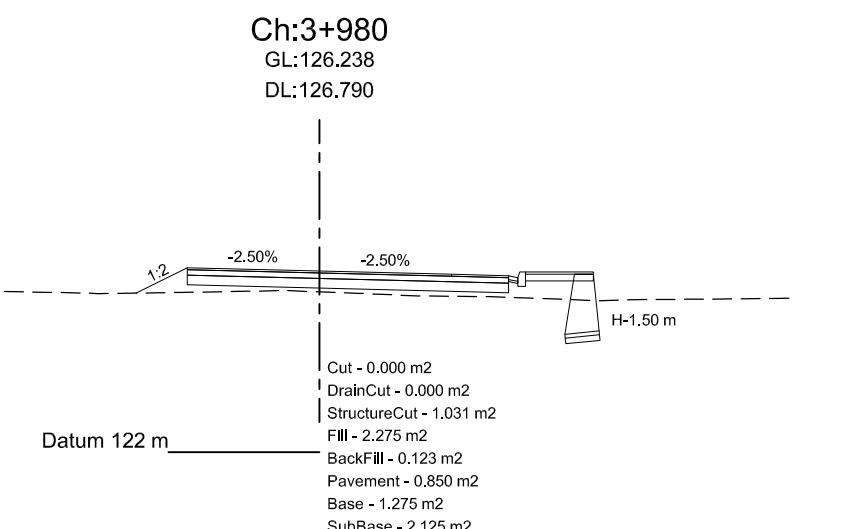
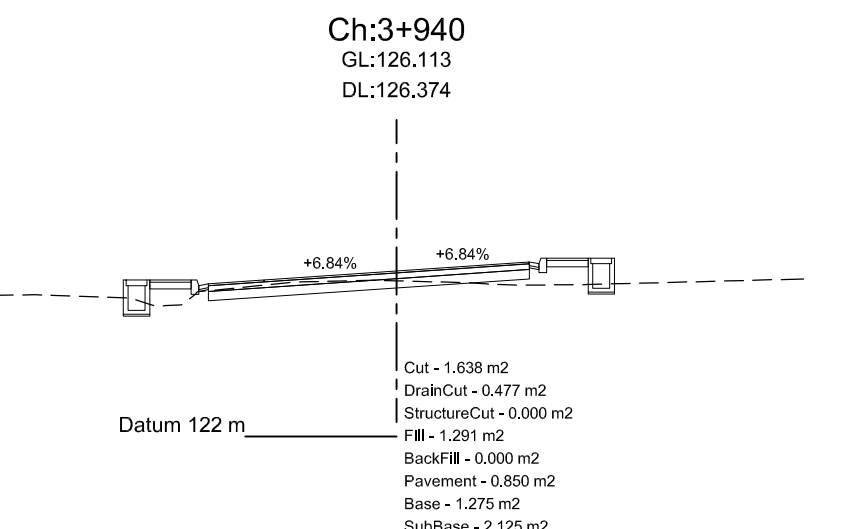
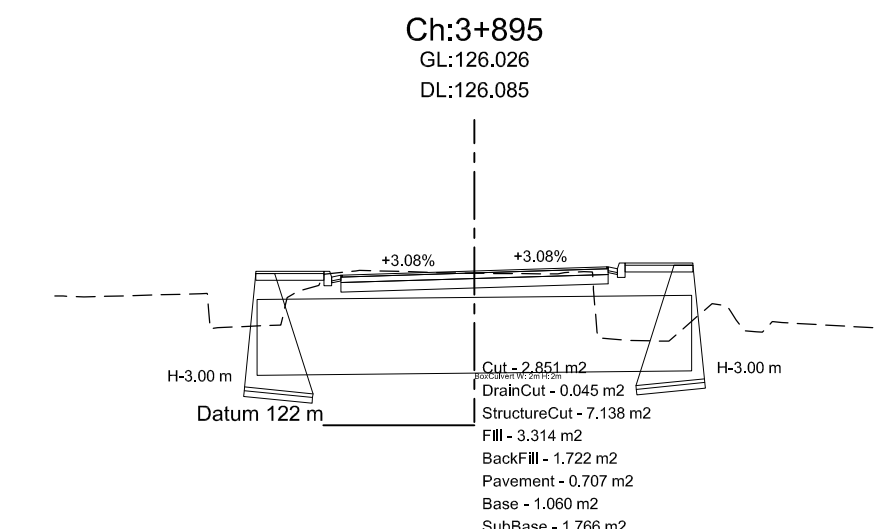
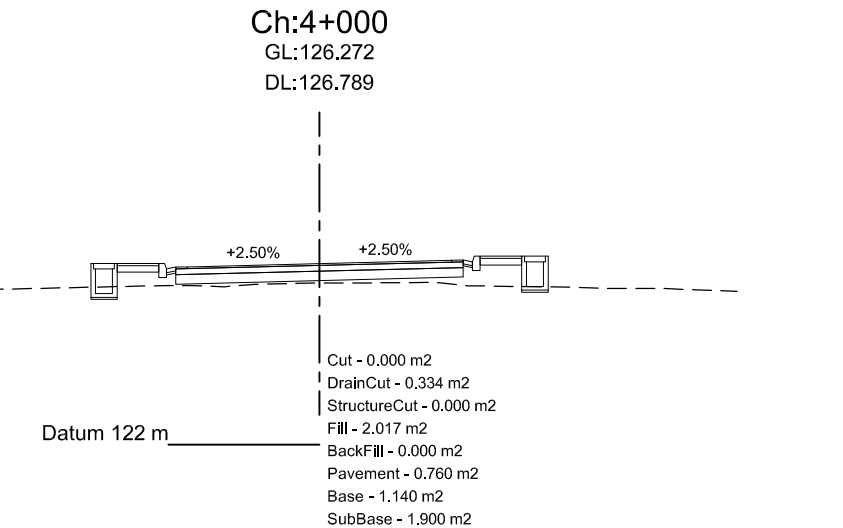
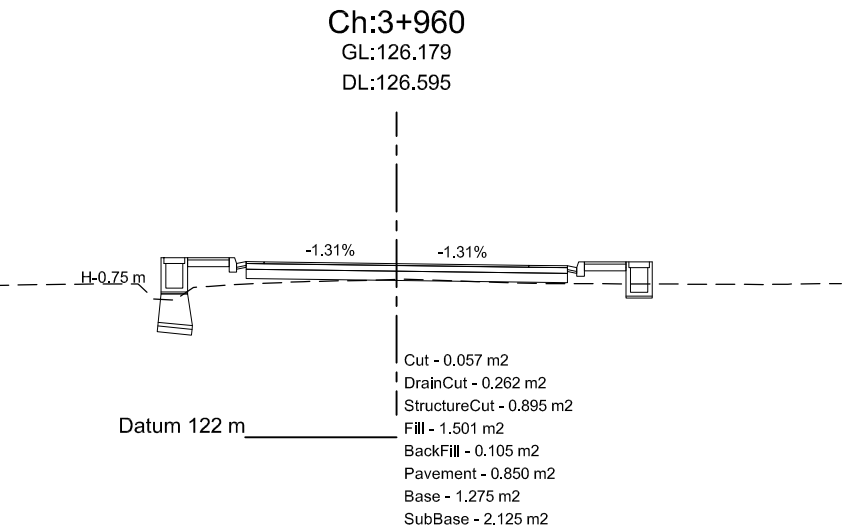
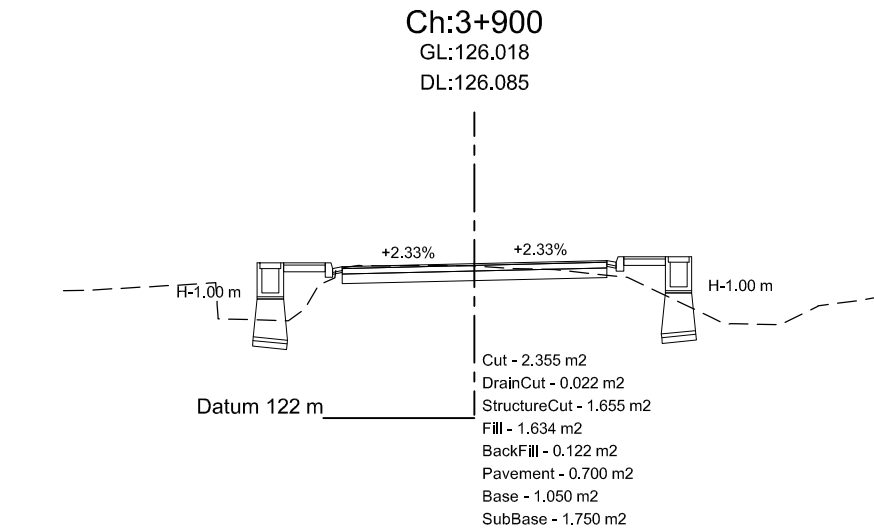
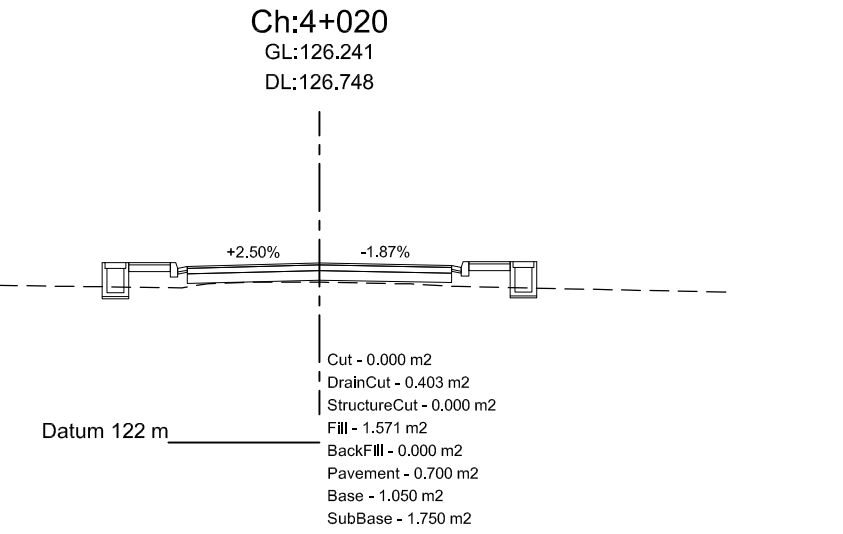
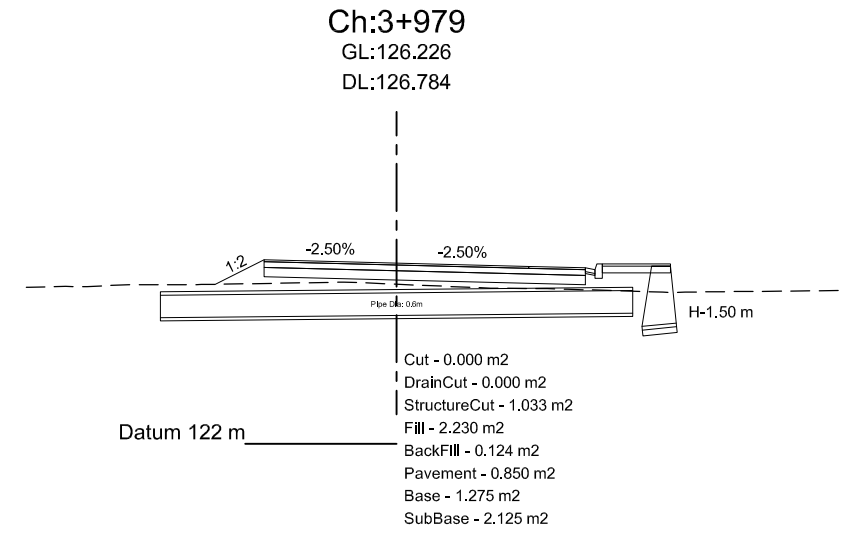
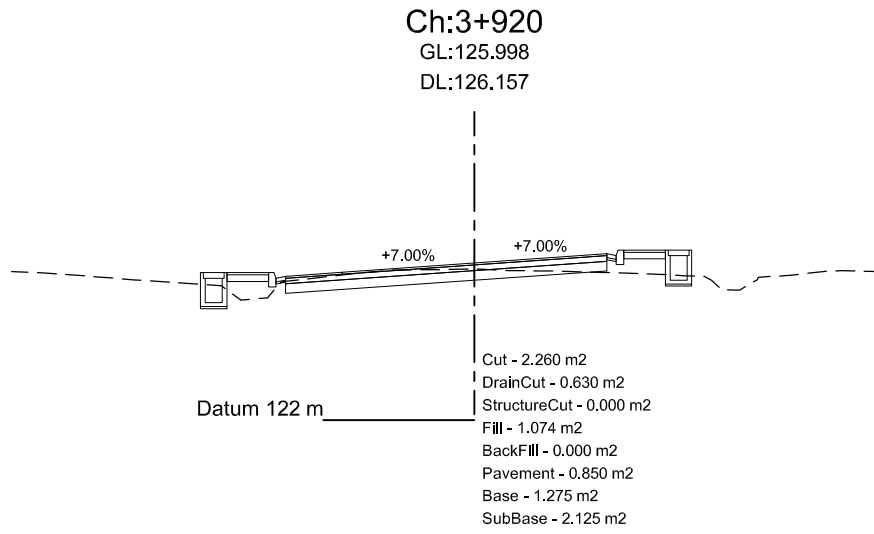

Department of Urban Development & Building Construction (DUDBC)
Regional Urban Development Project (RUDP)
West Urban Corridor (WUC) Development Project
Babarmahal, Kathmandu, Nepal

Reviewed & Designed By :
DOHWA Engineering Co. Ltd.
in Association with
ERMIC (P.) Ltd., SILT Consultants (P.) Ltd., and
DIGICON (P.) Ltd.
Mid-Baneshwor, Kathmandu
Tel: 01-4589393

Consultant
Team Leader : YOO CHANGMIN
Reviewed By : YAGYA BAHADUR MALLA
Designed By : MANJU MUNANKARMI

Client
Approved By :
Checked By :

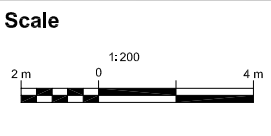

Cross-Section
BHALUHIPUL-MEDICAL COLLEGE-
BHATATOL-MUKHIYATOL-PIPARHIYA-
SINGHA-MUNICIPALITY
CH 0+000 - 7+503.82 Km

REV : MAY 2024
DRG NO : DM/RD/CS/24
CHAINAGE : 3+895-4+020
SHEET NO : 24

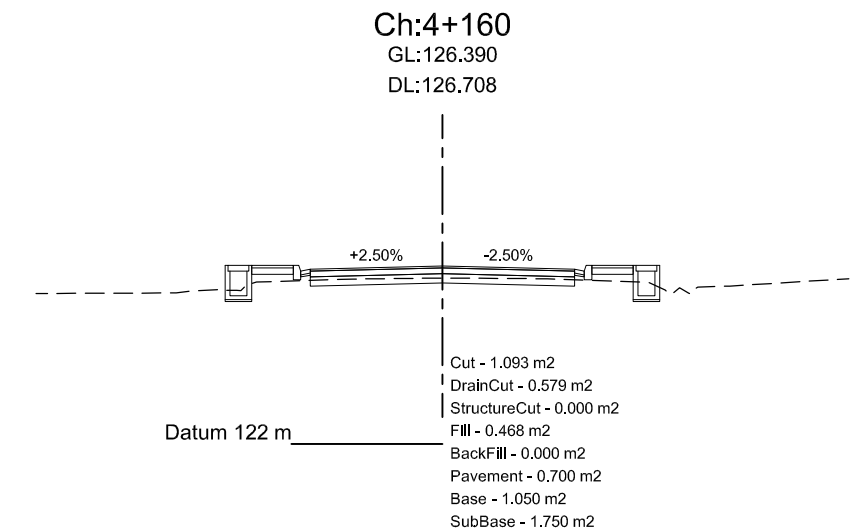
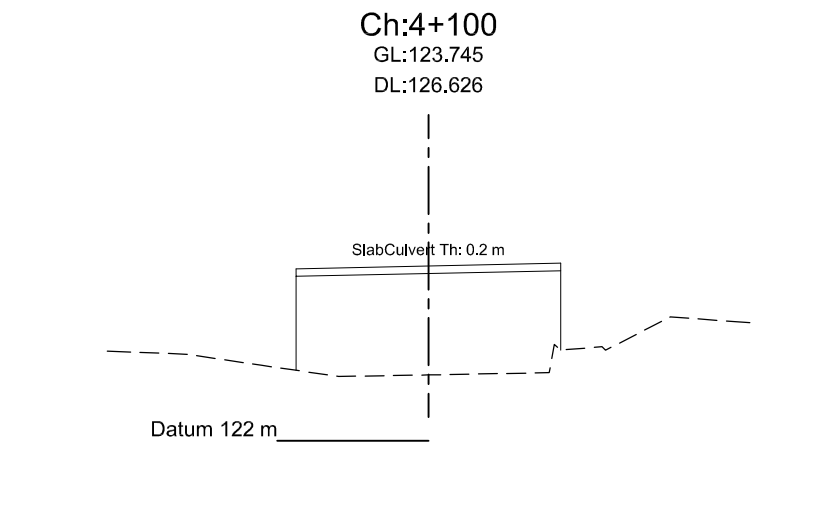
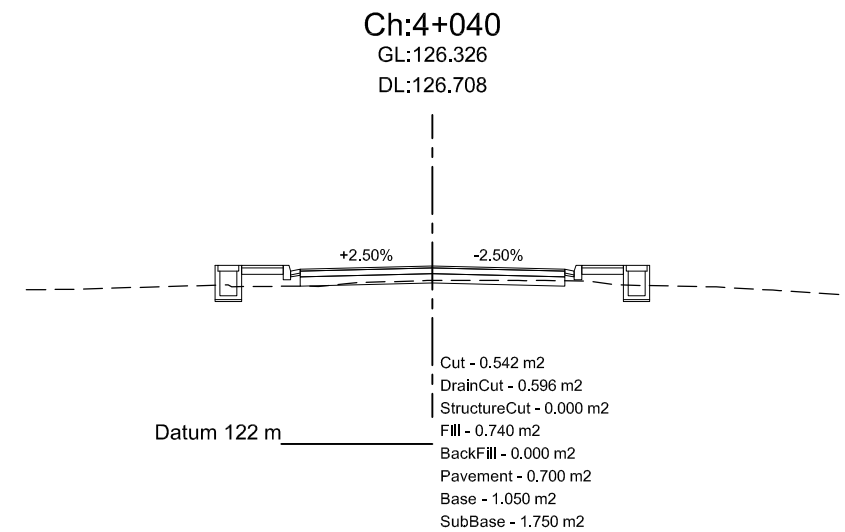
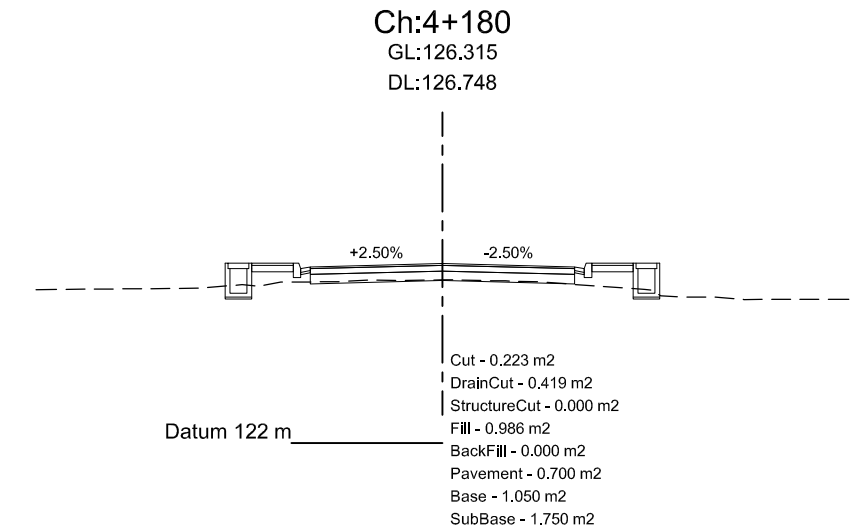
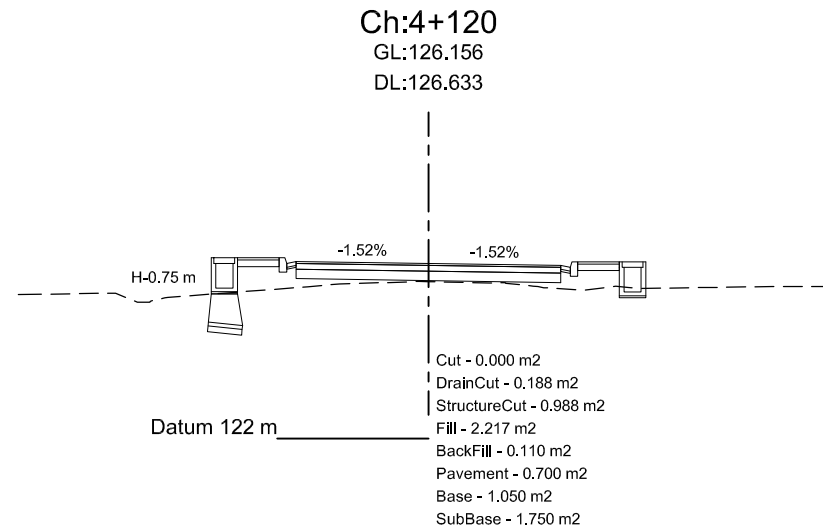
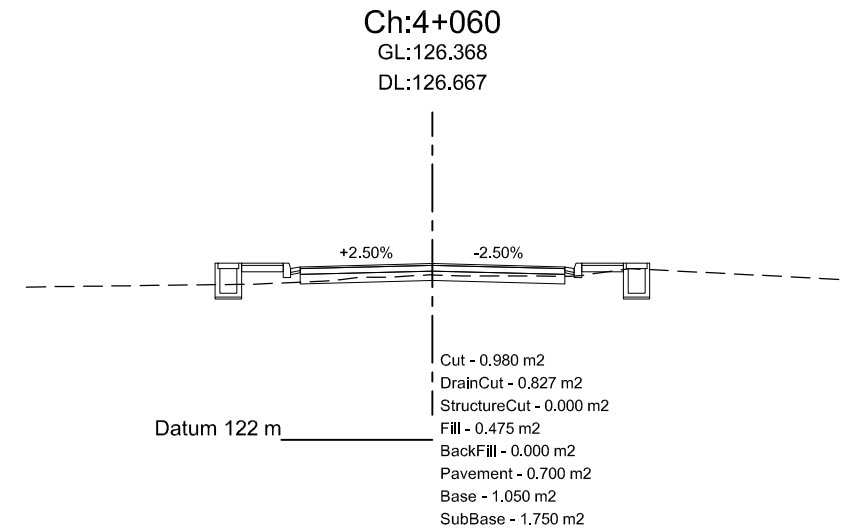
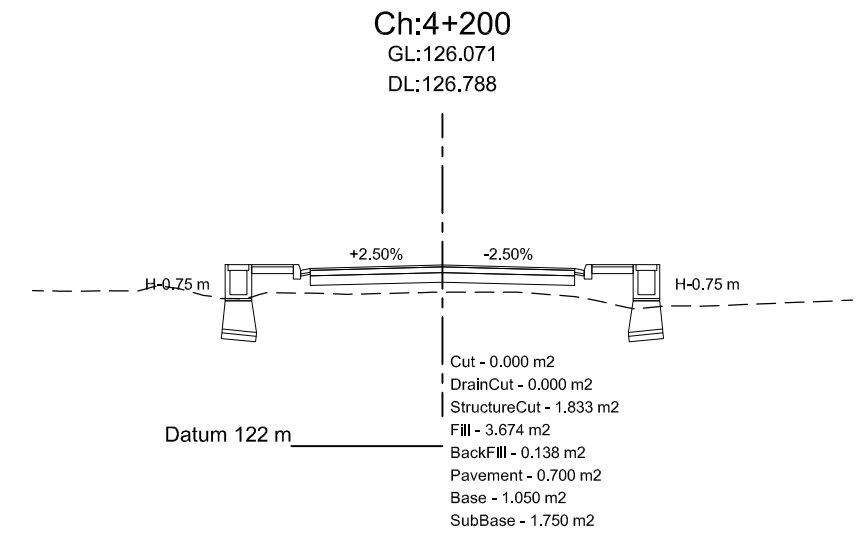
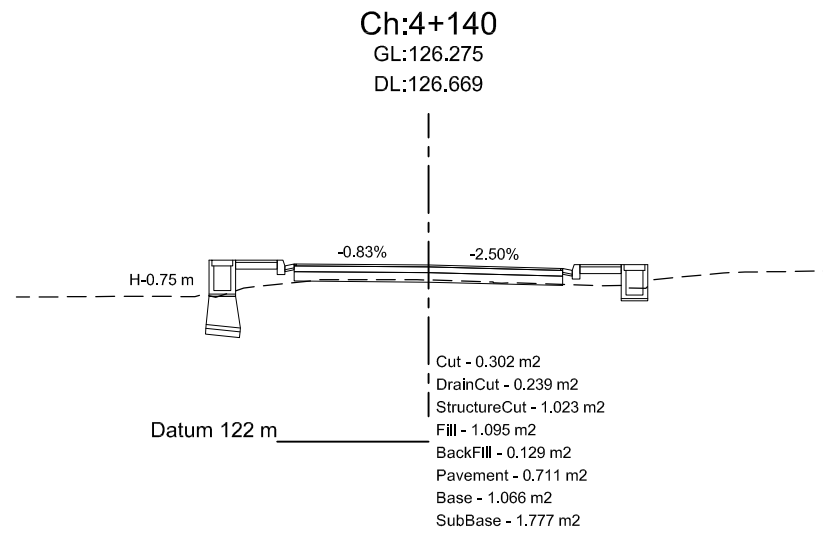
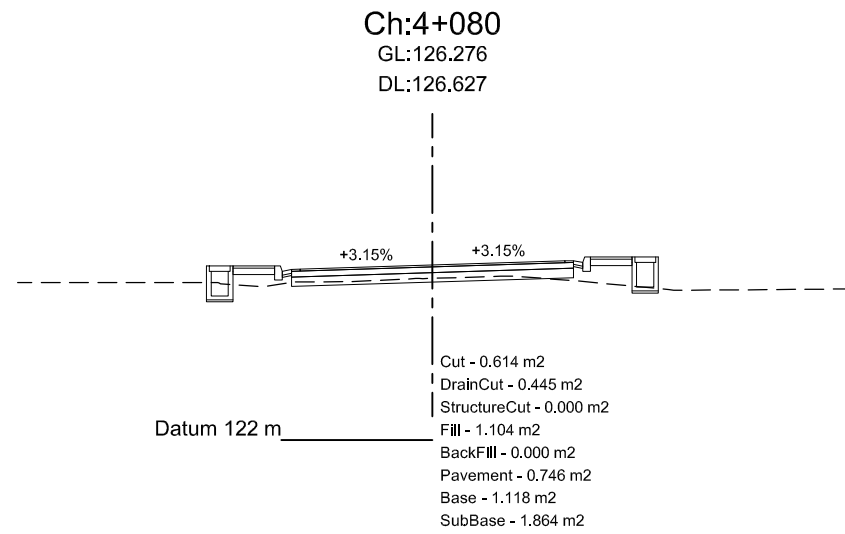

Department of Urban Development & Building
Construction (DUDBC)
Regional Urban Development Project (RUDP)
West Urban Corridor (WUC) Development Project
Babarmahal, Kathmandu, Nepal

Reviewed & Designed By :
DOHWA Engineering Co. Ltd.
in Association with
ERMIC (P.) Ltd., SILT Consultants (P.) Ltd., and
DIGICON (P.) Ltd.
Mid- Baneshwor, Kathmandu
Tel: 01- 4589393

Consultant
Team Leader : YOO CHANGMIN
Reviewed By : YAGYA BAHADUR MALLA
Designed By : MANJU MUNANKARMI

Client
Approved By :
Checked By :

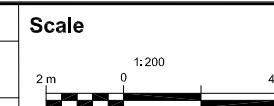

Cross-Section
BHALUHIPUL-MEDICAL COLLEGE-
BHATATOL-MUKHIYATOL-PIPARHIYA-
SINGHA-MUNICIPALITY
CH 0+000 - 7+503.82 Km

REV : MAY 2024
DRG NO : DM/RD/CS/25
CHAINAGE : 4+040-4+200
SHEET NO : 25

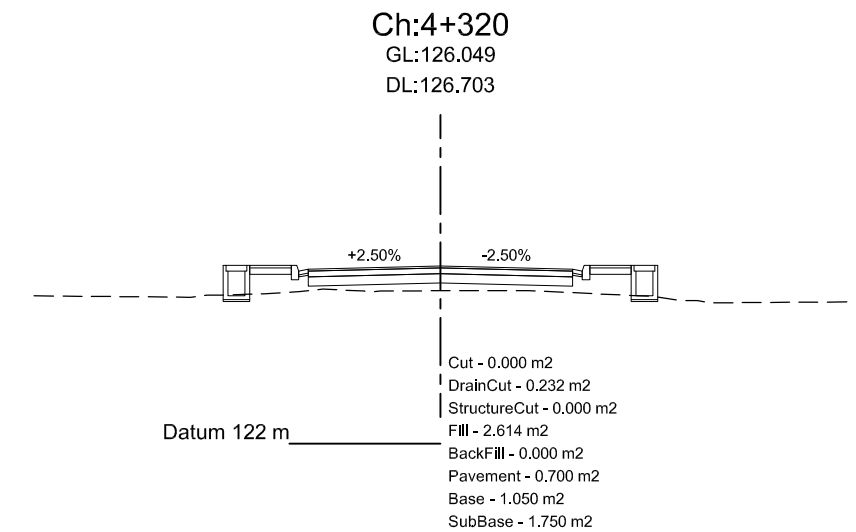
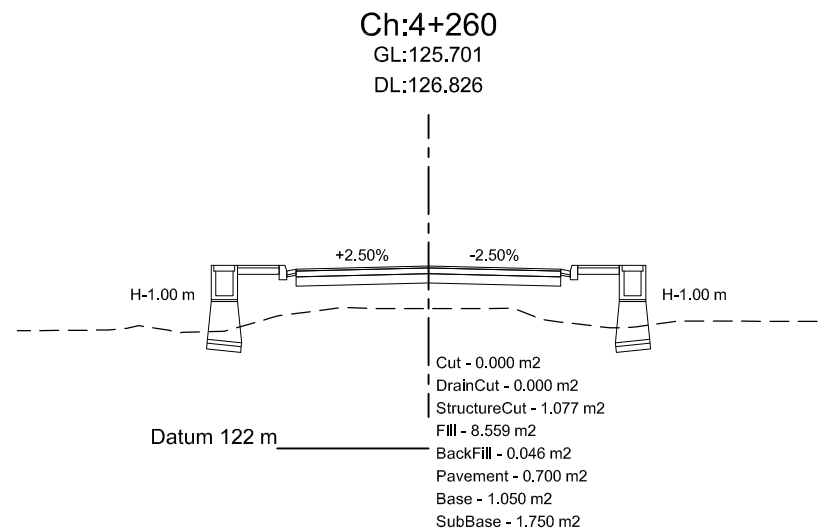
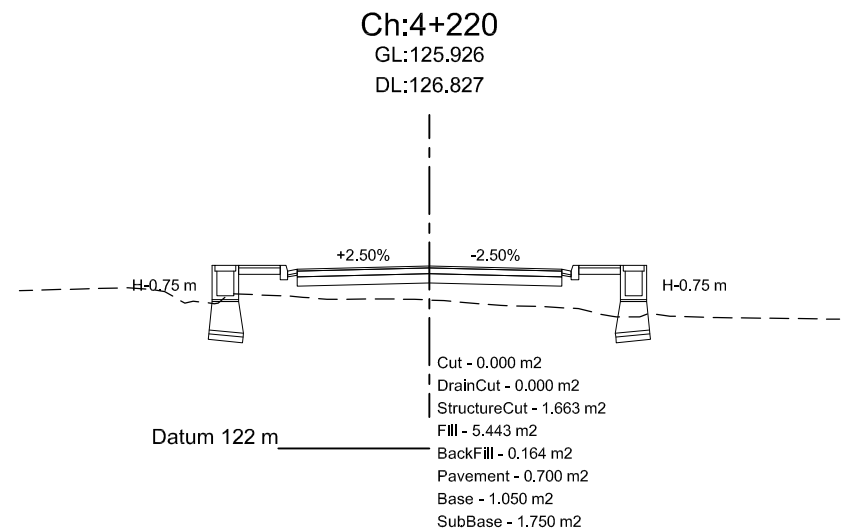
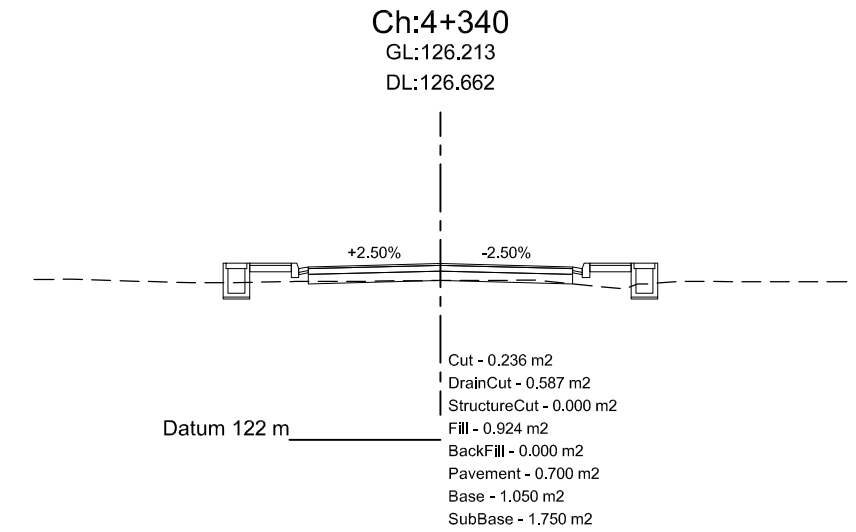
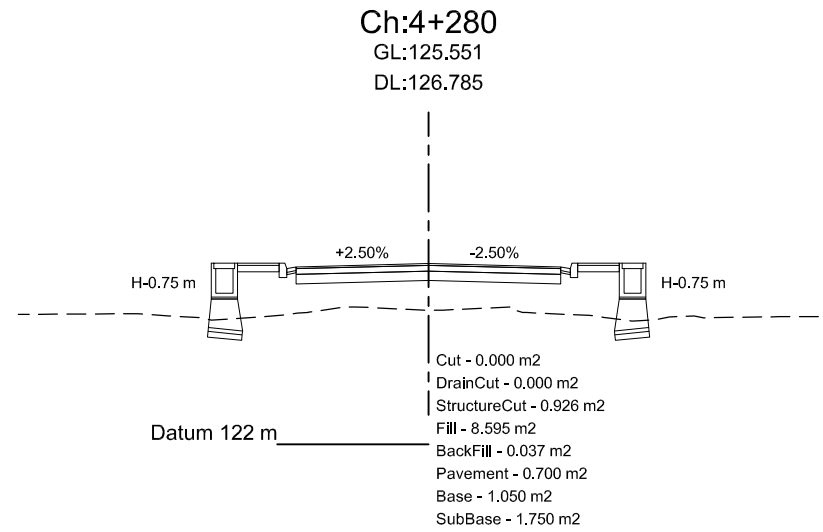
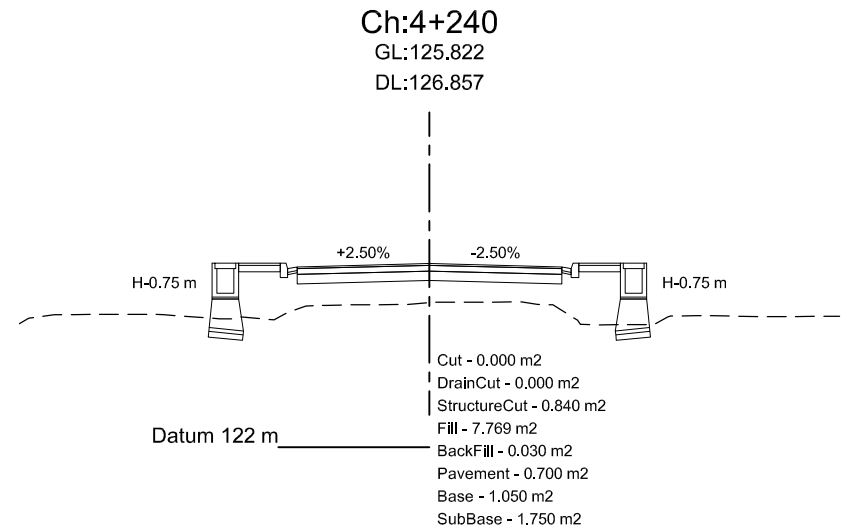
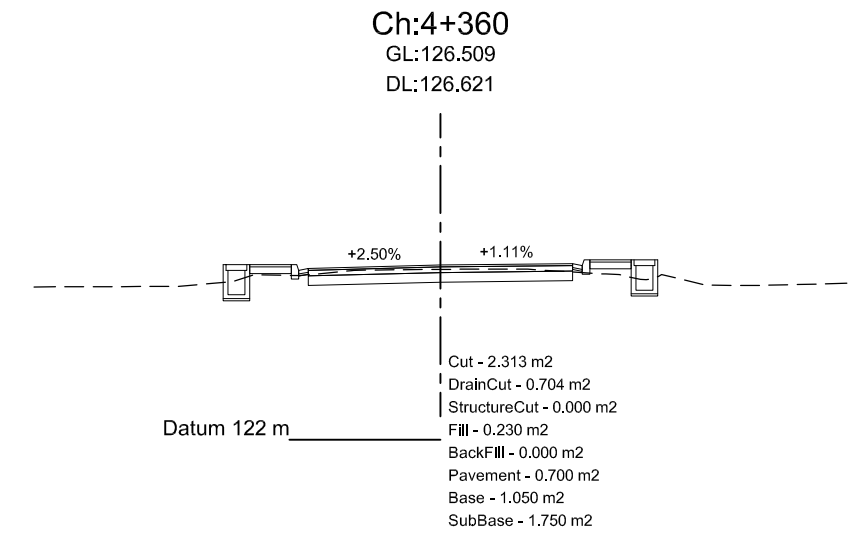
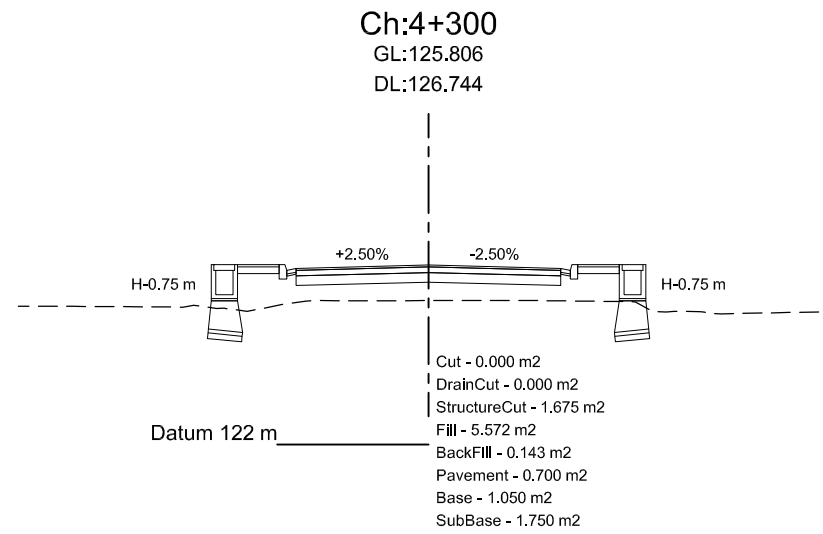
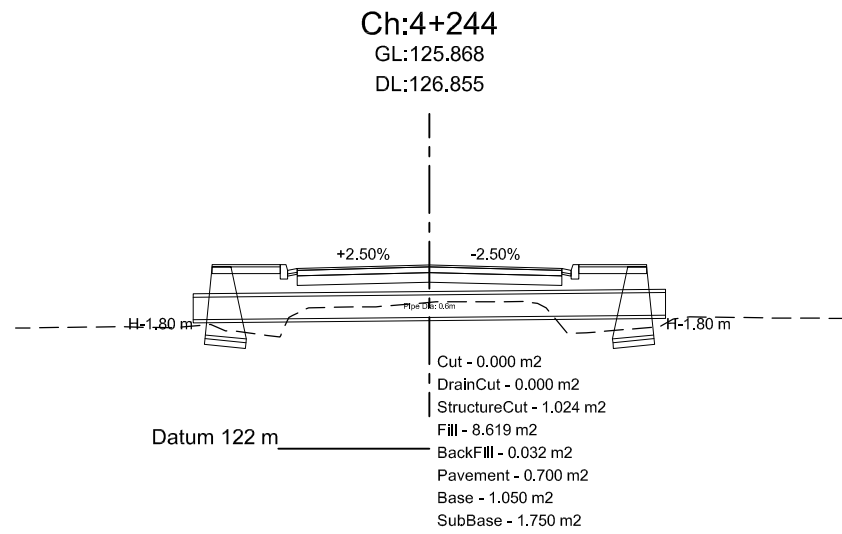

Department of Urban Development & Building
Construction (DUDBC)
Regional Urban Development Project (RUDP)
West Urban Corridor (WUC) Development Project
Babarmahal, Kathmandu, Nepal

Reviewed & Designed By :
DOHWA Engineering Co. Ltd.
in Association with
ERMIC (P.) Ltd., SILT Consultants (P.) Ltd., and
DIGICON (P.) Ltd.
Mid-Baneshwor, Kathmandu
Tel: 01-4589393

Consultant
Team Leader : YOO CHANGMIN
Reviewed By : YAGYA BAHADUR MALLA
Designed By : MANJU MUNANKARMI

Client
Approved By :
Checked By :

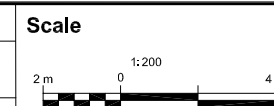

Cross-Section
BHALUHIPUL-MEDICAL COLLEGE-
BHATATOL-MUKHIYATOL-PIPARHIYA-
SINGHA-MUNICIPALITY
CH 0+000 - 7+503.82 Km

REV : MAY 2024
DRG NO : DM/RD/CS/26
CHAINAGE : 4+220-4+360
SHEET NO : 26

Ch:4+400

GL:126.533
DL:126.580

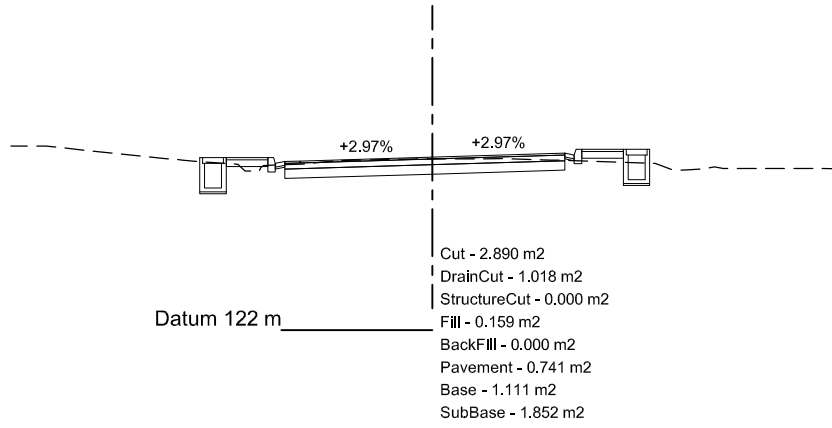

Ch:4+460

GL:126.667
DL:126.700

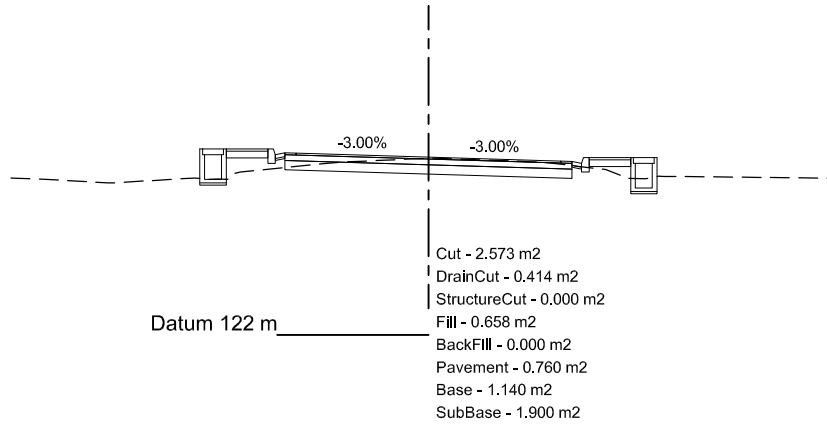

Ch:4+519

GL:126.526
DL:126.661

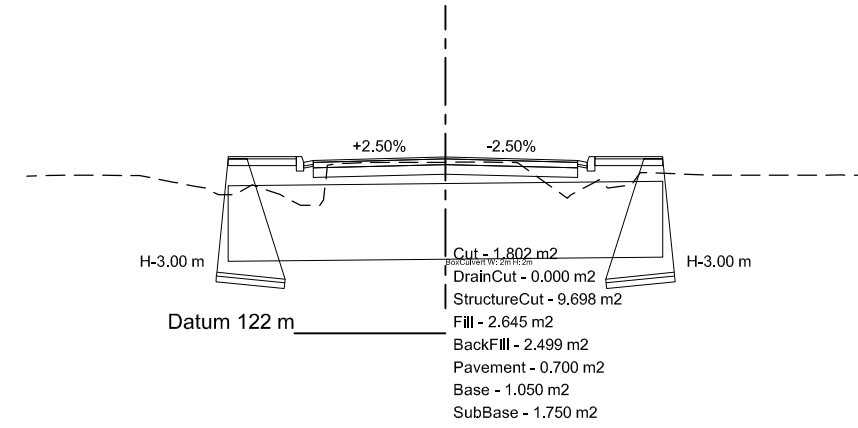

Ch:4+390

GL:126.508
DL:126.570

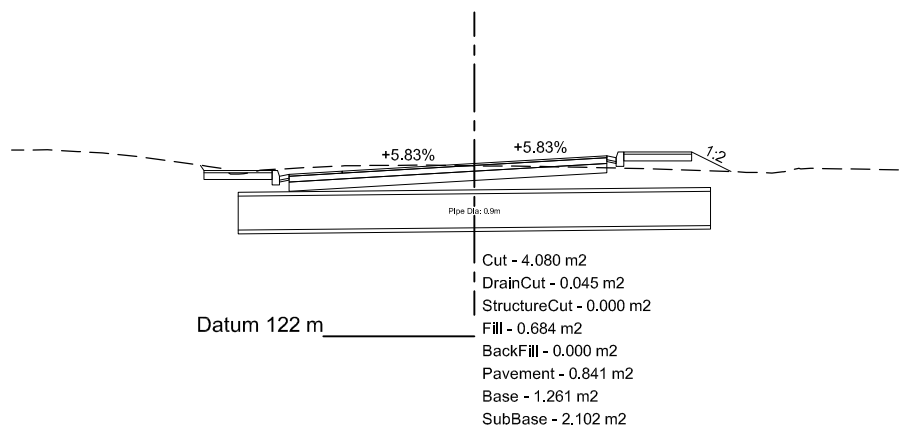

Ch:4+440

GL:126.585
DL:126.660

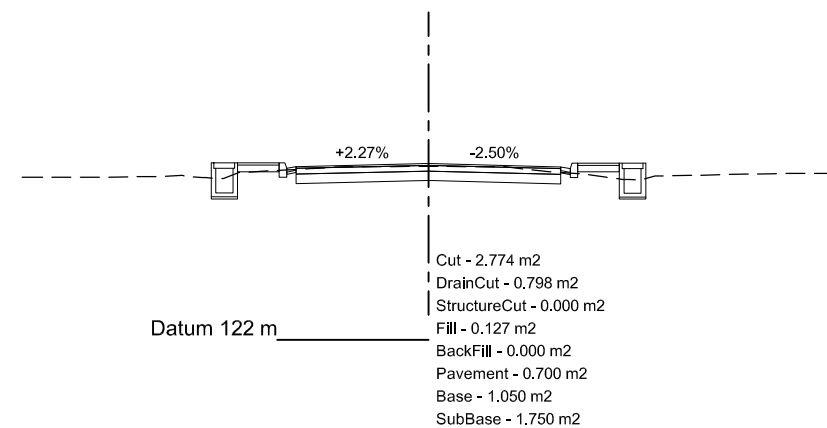

Ch:4+500

GL:126.607
DL:126.701

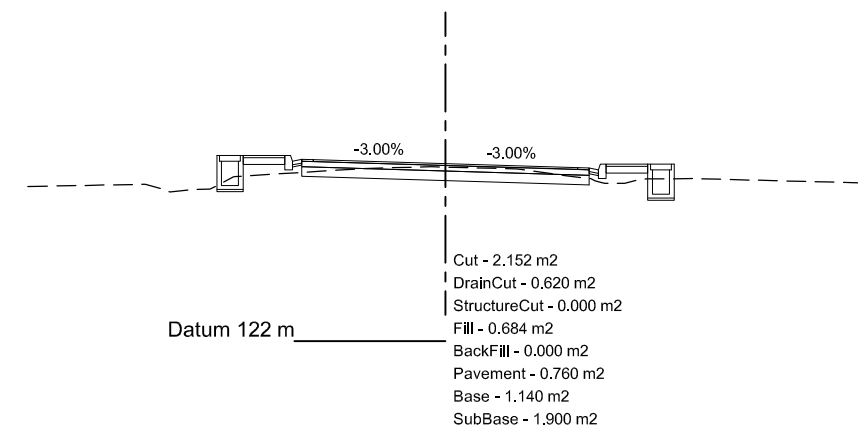

Ch:4+380

GL:126.560
DL:126.581

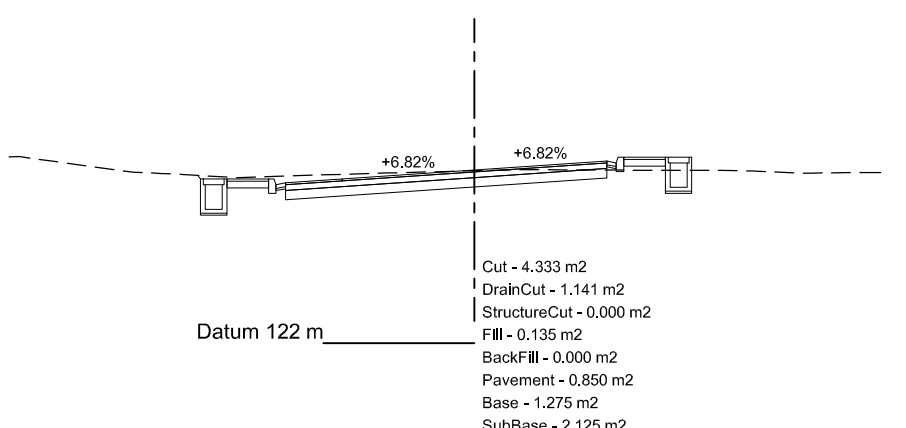

Ch:4+420

GL:126.581
DL:126.620

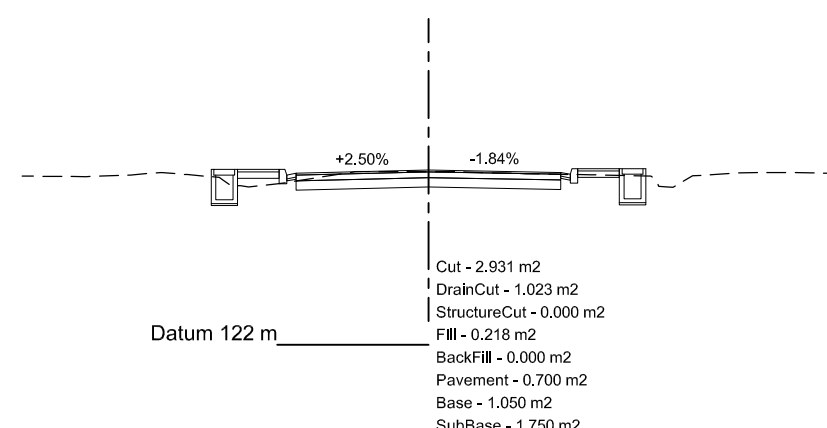

Ch:4+480

GL:126.659
DL:126.741

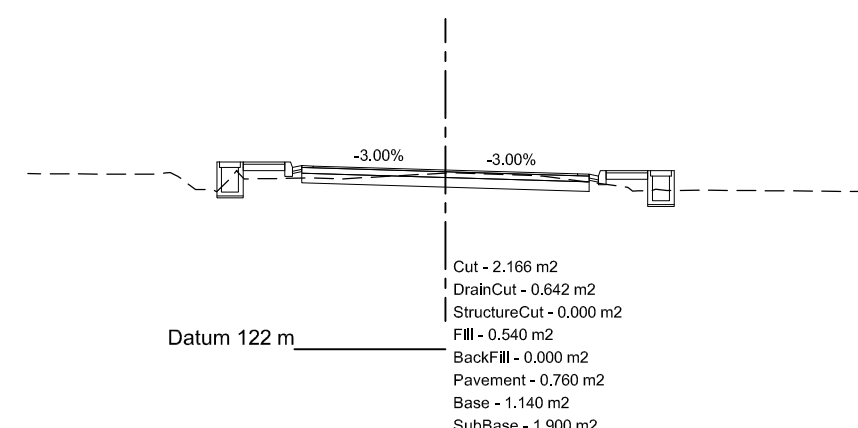

Department of Urban Development & Building Construction (DUDBC)
Regional Urban Development Project (RUDP)
West Urban Corridor (WUC) Development Project
Babarmahal, Kathmandu, Nepal

Reviewed & Designed By :
DOHWA Engineering Co. Ltd.
in Association with
ERMIC (P.) Ltd., SILT Consultants (P.) Ltd., and
DIGICON (P.) Ltd.
Mid- Baneshwor, Kathmandu
Tel: 01- 4589393

Consultant
Team Leader : YOO CHANGMIN
Reviewed By : YAGYA BAHADUR MALLA
Designed By : MANJU MUNANKARMI

Client
Approved By :
Checked By :

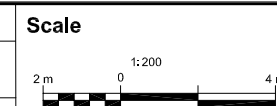

Cross-Section
BHALUHIPUL-MEDICAL COLLEGE-
BHATATOL-MUKHIYATOL-PIPARHIYA-
SINGHA-MUNICIPALITY
CH 0+000 - 7+503.82 Km

REV : MAY 2024
DRG NO : DM/RD/CS/27
CHAINAGE : 4+380-4+519
SHEET NO : 27

Ch:4+560

GL:126.876

DL:126.947

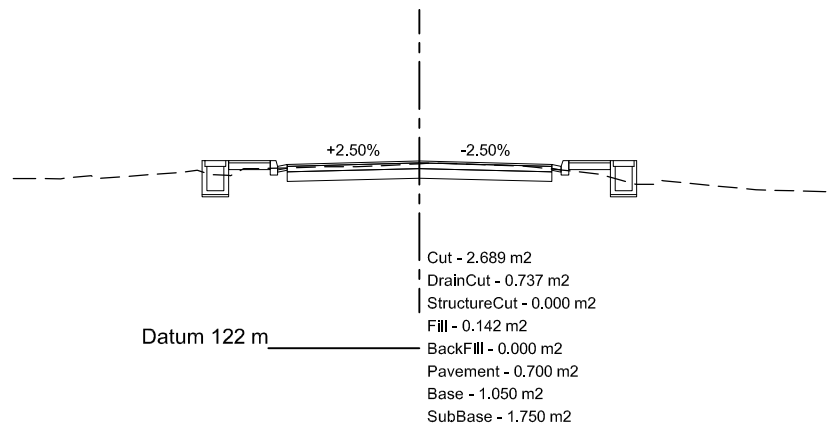

Ch:4+620

GL:126.977

DL:127.112

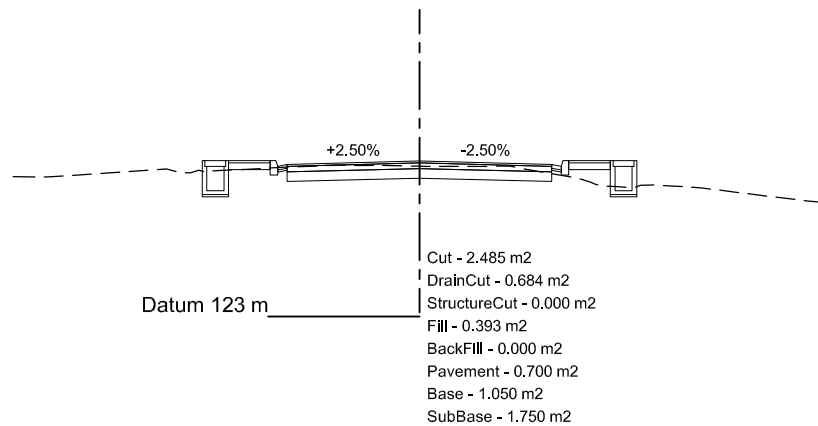

Ch:4+680

GL:127.004

DL:127.234

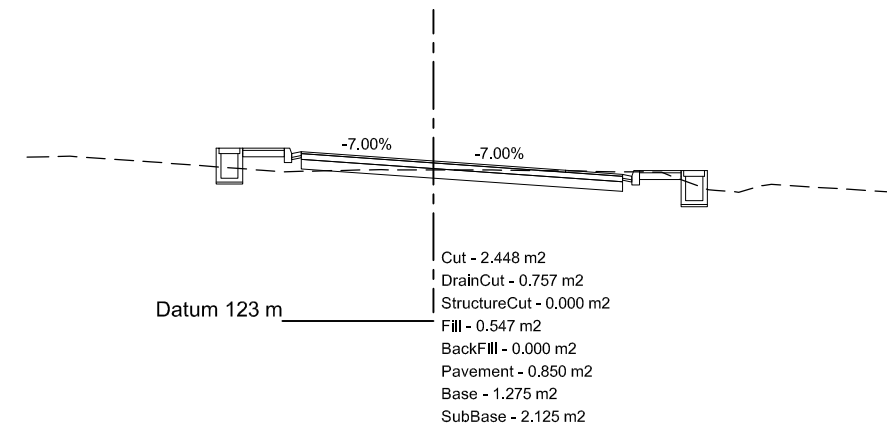

Ch:4+540

GL:126.681

DL:126.737

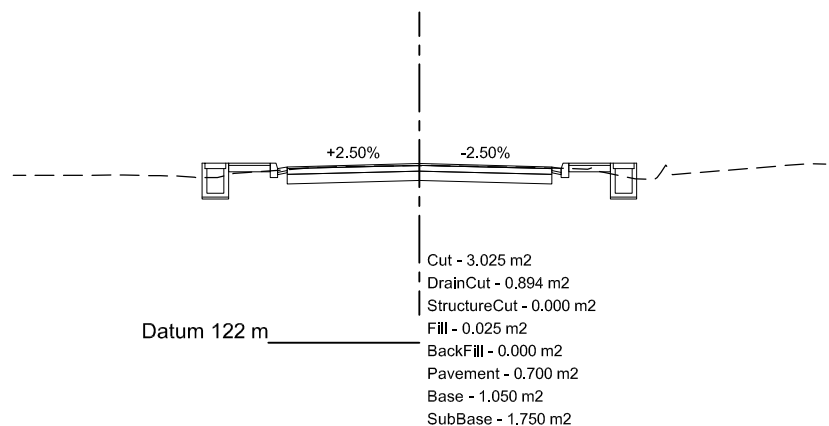

Ch:4+600

GL:126.986

DL:127.071

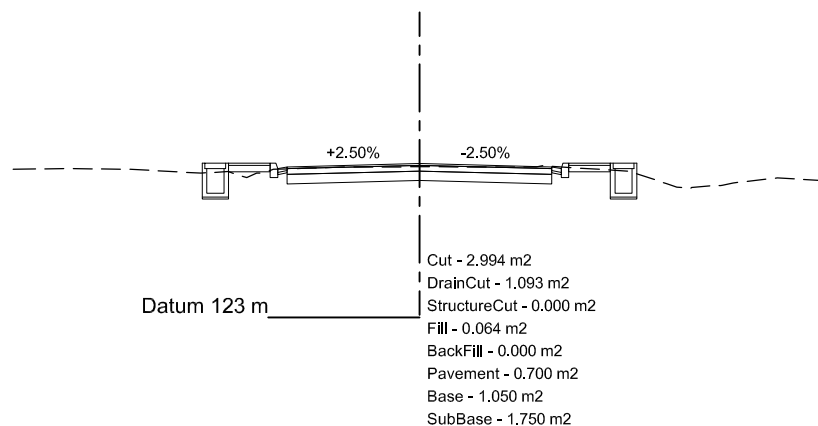

Ch:4+660

GL:127.112

DL:127.193

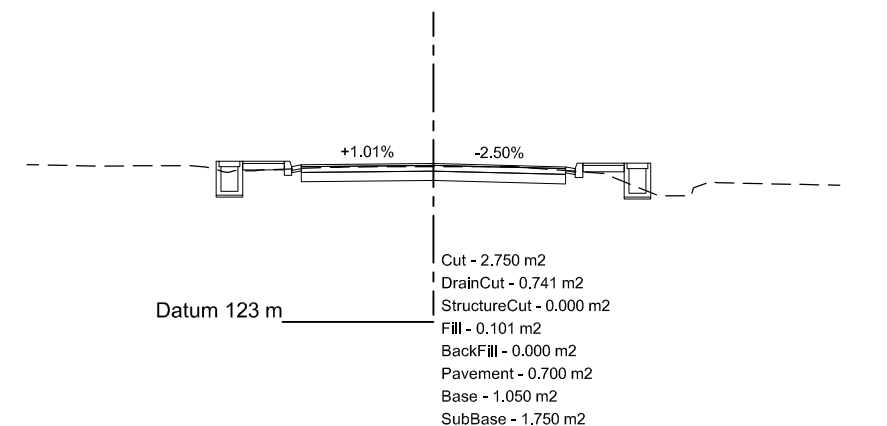

Ch:4+520

GL:126.518

DL:126.661

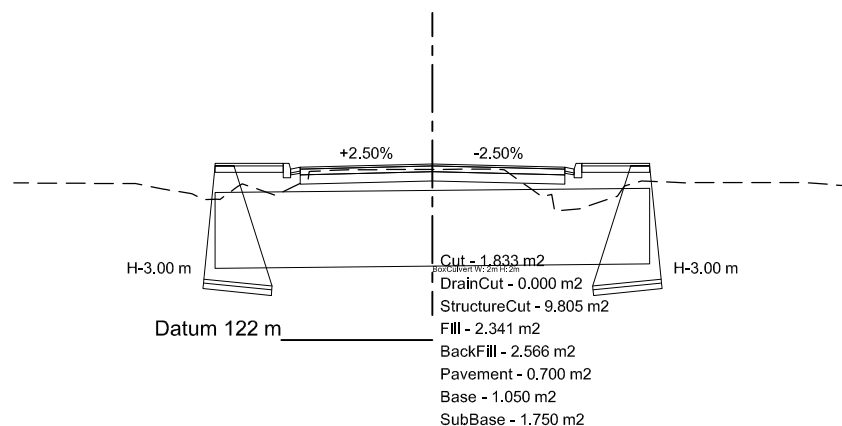

Ch:4+580

GL:126.913

DL:127.031

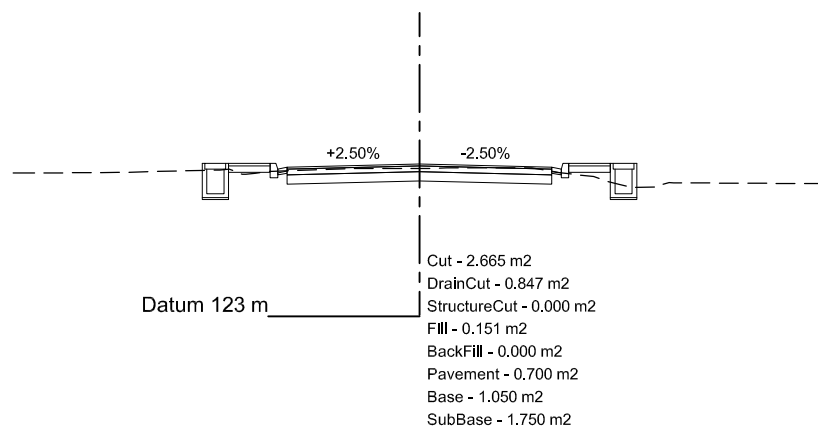

Ch:4+640

GL:127.035

DL:127.153

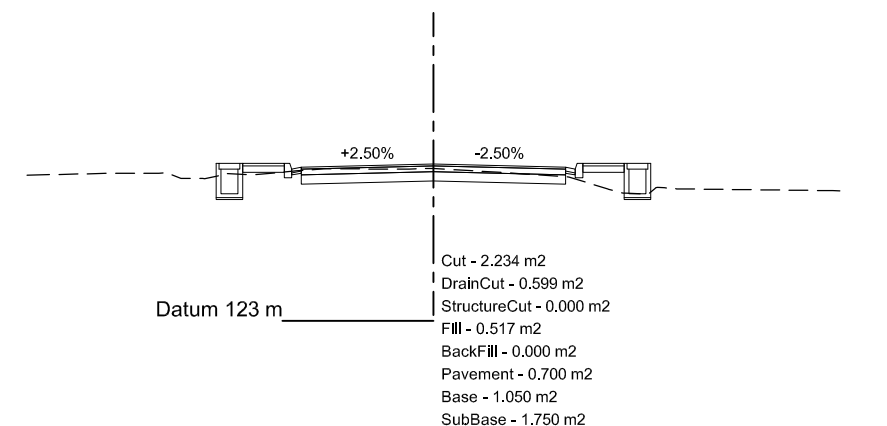

Department of Urban Development & Building
 Construction (DUDBC)
Regional Urban Development Project (RUDP)
 West Urban Corridor (WUC) Development Project
 Babarmahal, Kathmandu, Nepal

Reviewed & Designed By :
DOHWA Engineering Co. Ltd.
 in Association with
ERMIC (P.) Ltd., SILT Consultants (P.) Ltd., and
DIGICON (P.) Ltd.
 Mid- Baneshwor, Kathmandu
 Tel: 01- 4589393

Consultant
Team Leader : YOO CHANGMIN
Reviewed By : YAGYA BAHADUR MALLA
Designed By : MANJU MUNANKARMI

Client
Approved By :
Checked By :

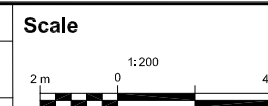

Cross-Section
BHALUHIPUL-MEDICAL COLLEGE-
BHATATOL-MUKHIYATOL-PIPARHIYA-
SINGHA-MUNICIPALITY
CH 0+000 - 7+503.82 Km

REV : MAY 2024
DRG NO : DM/RD/CS/28
CHAINAGE : 4+520-4+680
SHEET NO : 28

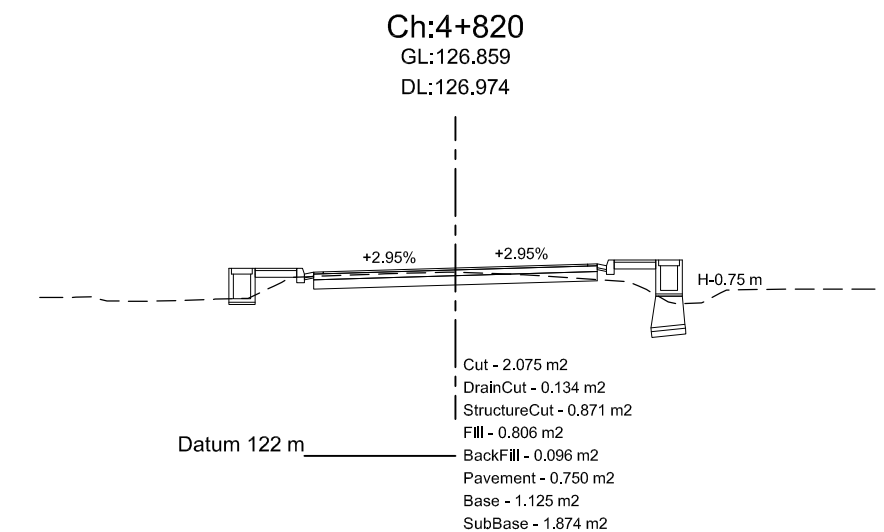
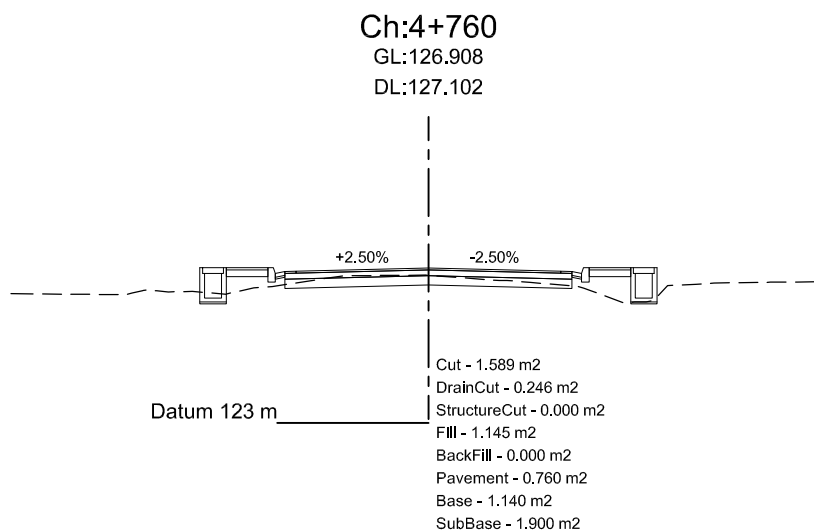
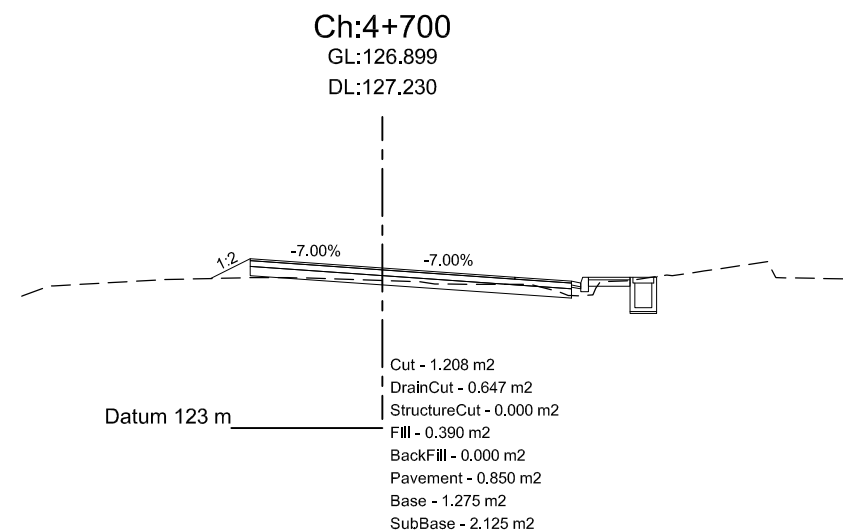
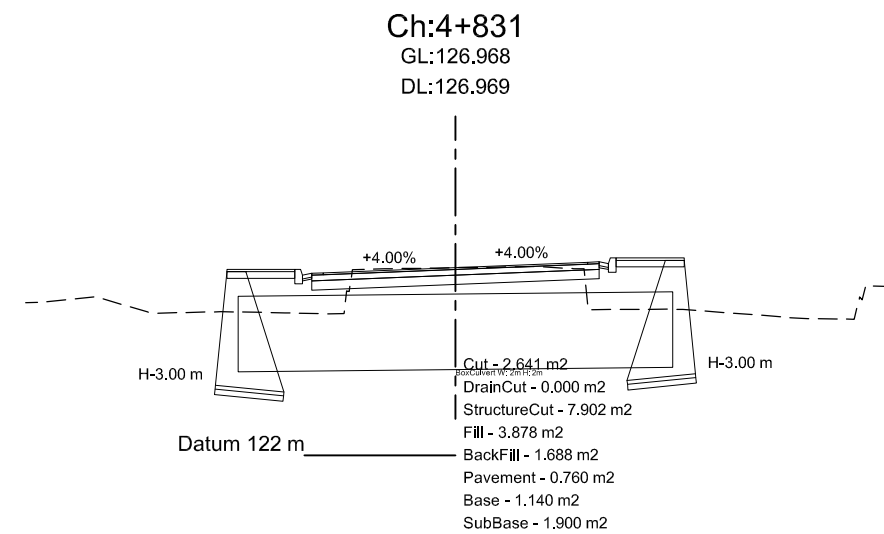
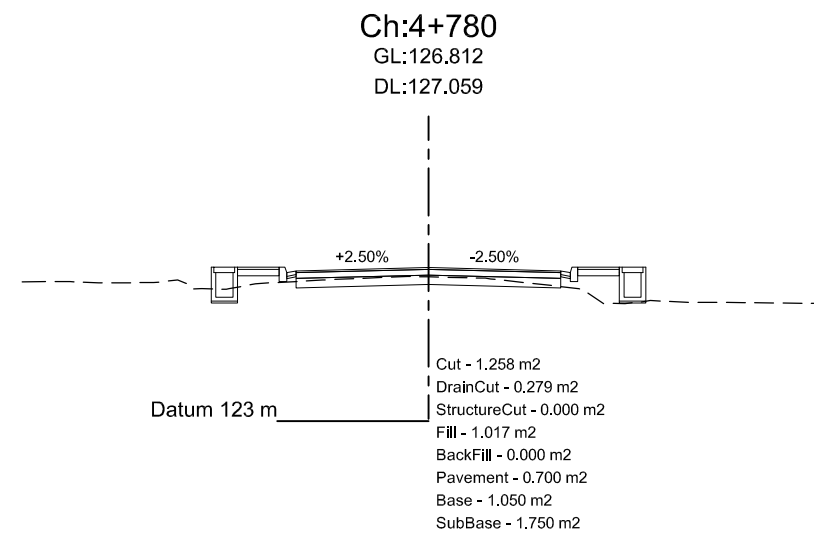
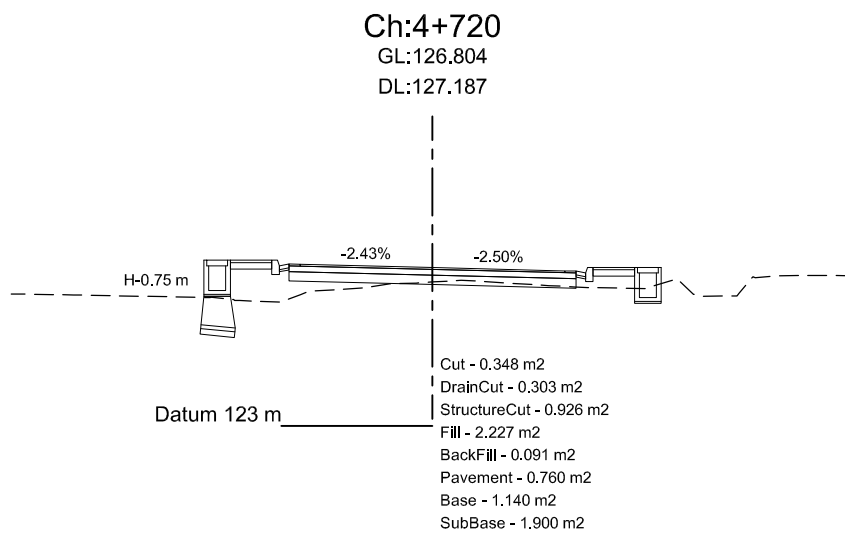
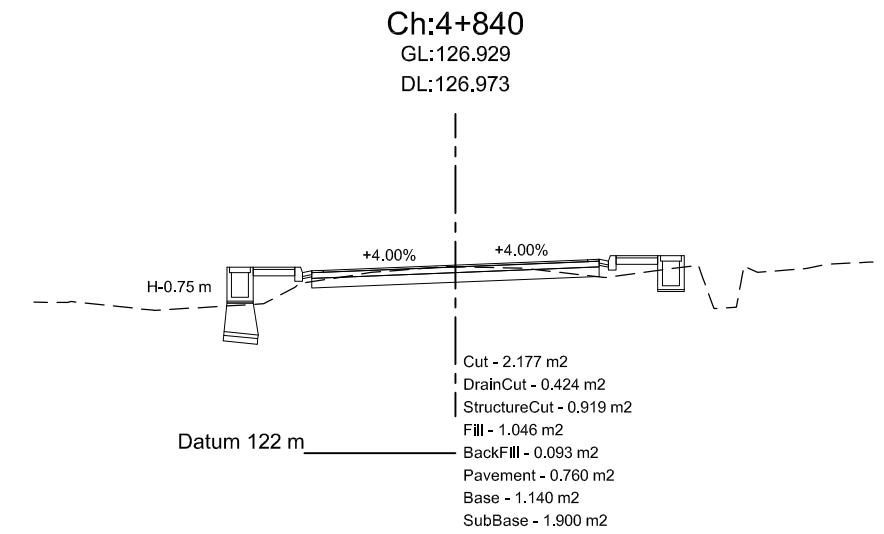
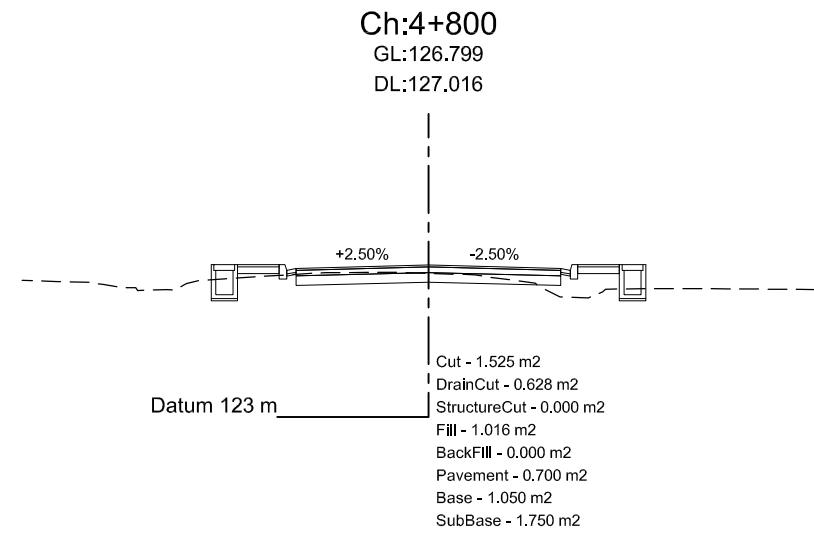
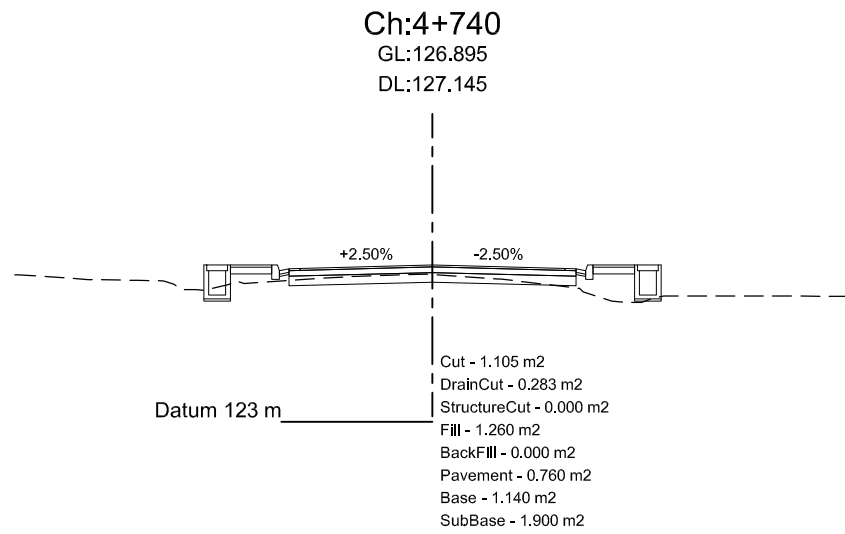

Department of Urban Development & Building Construction (DUDBC)
Regional Urban Development Project (RUDP)
West Urban Corridor (WUC) Development Project
Babarmahal, Kathmandu, Nepal

Reviewed & Designed By :
DOHWA Engineering Co. Ltd.
in Association with
ERMIC (P.) Ltd., SILT Consultants (P.) Ltd., and
DIGICON (P.) Ltd.
Mid-Baneshwor, Kathmandu
Tel: 01-4589393

Consultant
Team Leader : YOO CHANGMIN
Reviewed By : YAGYA BAHADUR MALLA
Designed By : MANJU MUNANKARMI

Client
Approved By :
Checked By :

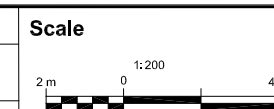

Cross-Section
BHALUHIPUL-MEDICAL COLLEGE-
BHATATOL-MUKHIYATOL-PIPARHIYA-
SINGHA-MUNICIPALITY
CH 0+000 - 7+503.82 Km

REV : MAY 2024
DRG NO : DM/RD/CS/29
CHAINAGE : 4+700-4+840
SHEET NO : 29

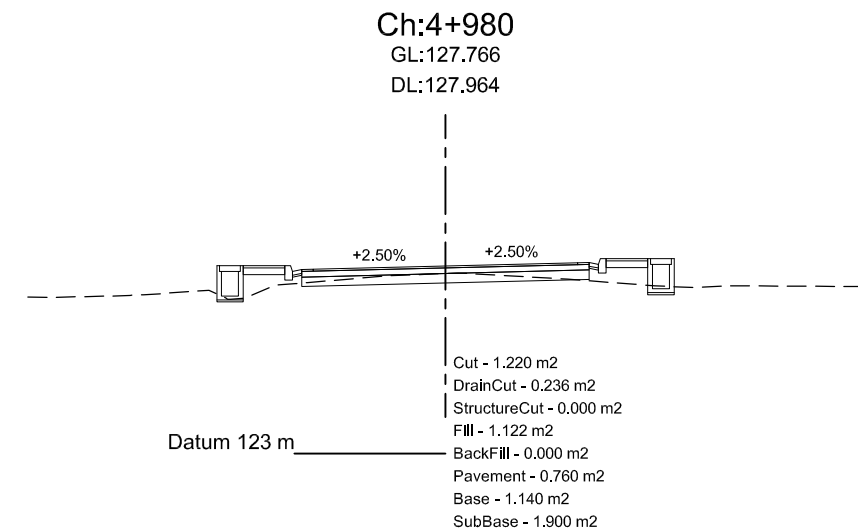
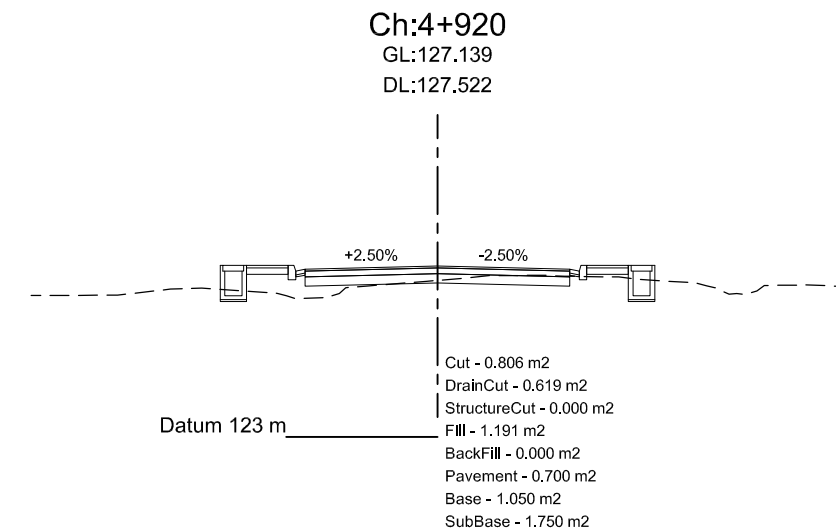
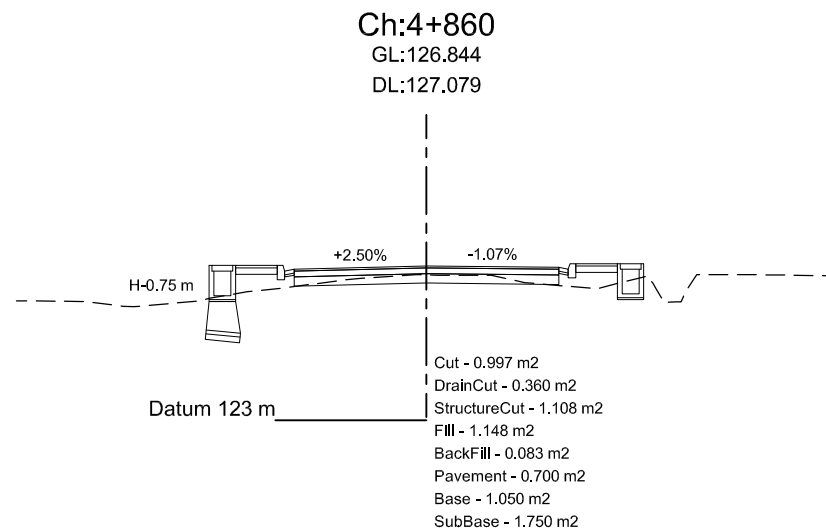
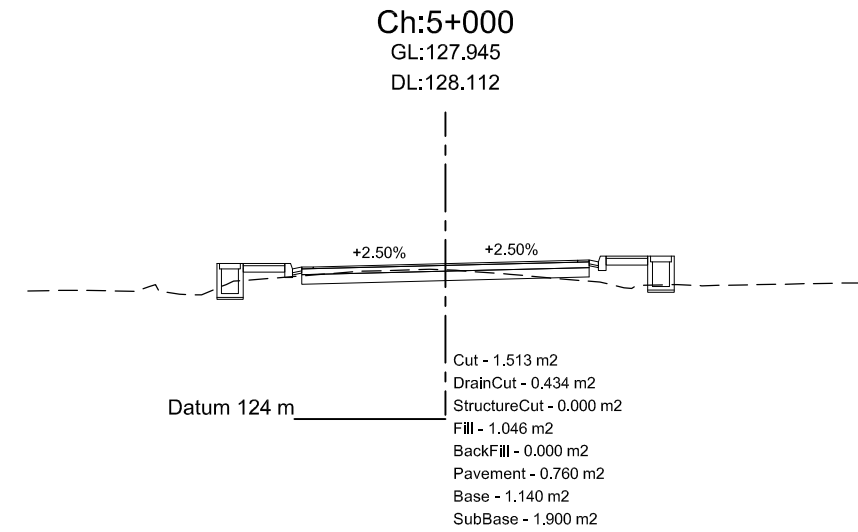
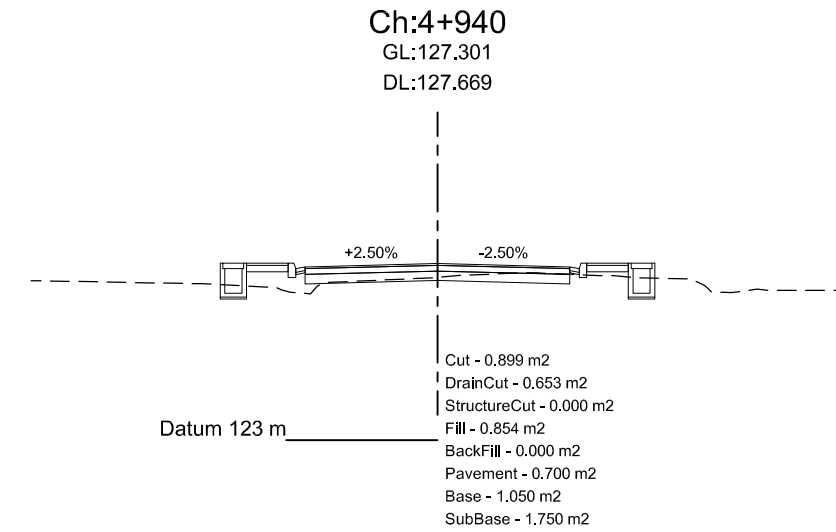
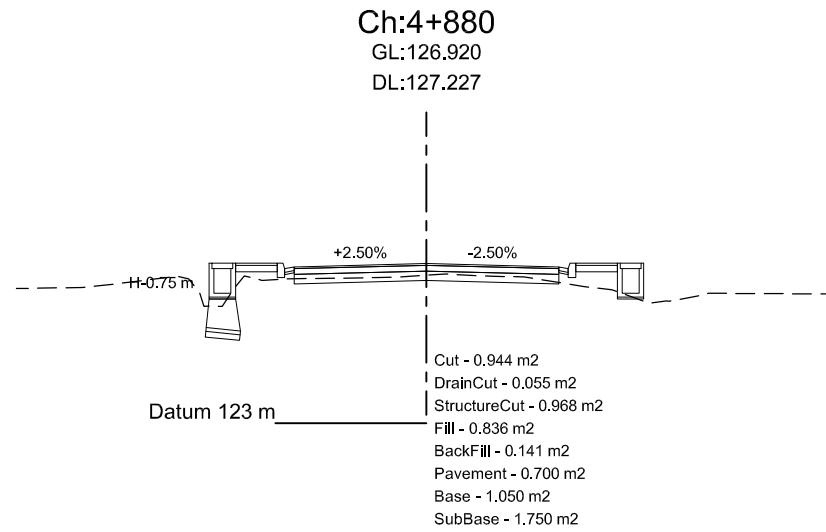
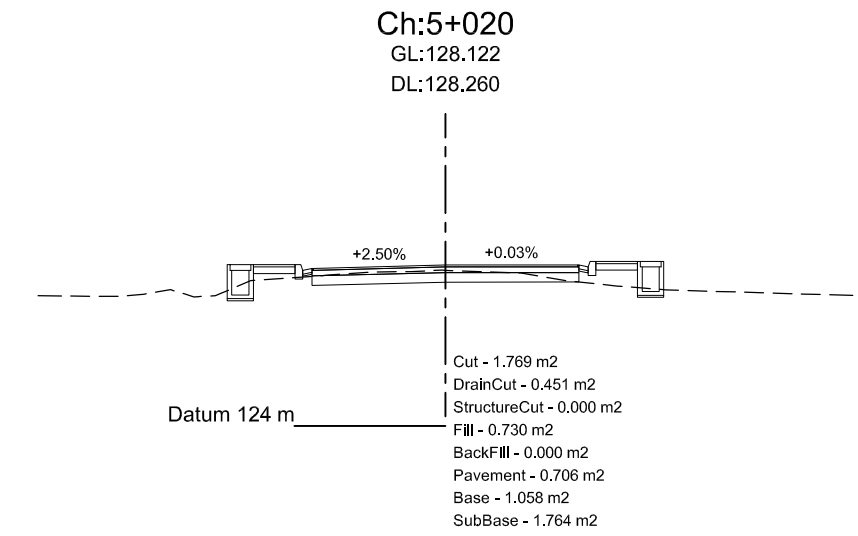
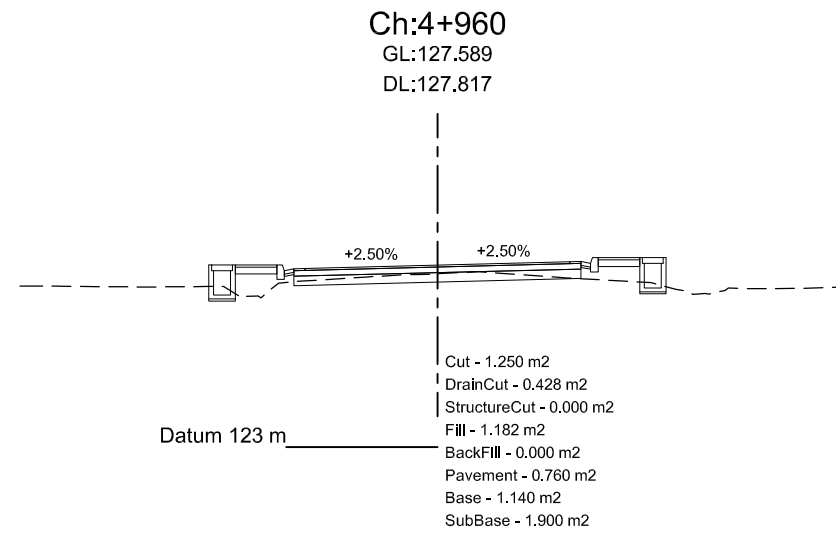
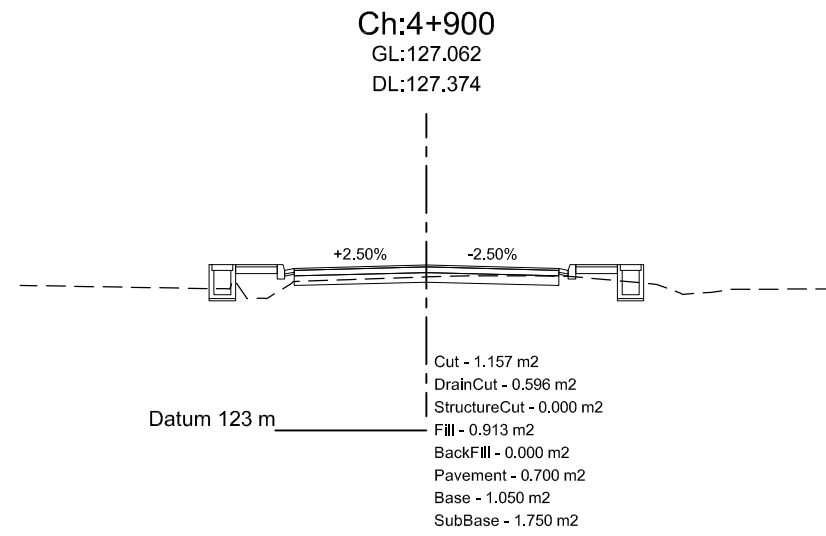

Department of Urban Development & Building
Construction (DUDBC)
Regional Urban Development Project (RUDP)
West Urban Corridor (WUC) Development Project
Babarmahal, Kathmandu, Nepal

Reviewed & Designed By :
DOHWA Engineering Co. Ltd.
in Association with
ERMIC (P.) Ltd., SILT Consultants (P.) Ltd., and
DIGICON (P.) Ltd.
Mid- Baneshwor, Kathmandu
Tel: 01- 4589393

Consultant
Team Leader : YOO CHANGMIN
Reviewed By : YAGYA BAHADUR MALLA
Designed By : MANJU MUNANKARMI

Client
Approved By :
Checked By :

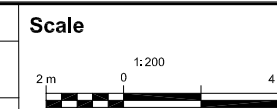

Cross-Section
BHALUHIPUL-MEDICAL COLLEGE-
BHATATOL-MUKHIYATOL-PIPARHIYA-
SINGHA-MUNICIPALITY
CH 0+000 - 7+503.82 Km

REV : MAY 2024
DRG NO : DM/RD/CS/30
CHAINAGE : 4+860-5+020
SHEET NO : 30

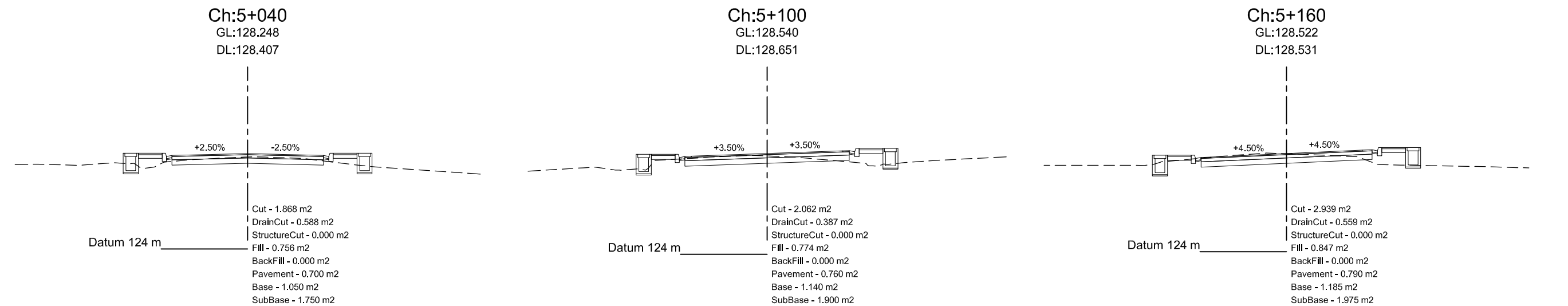
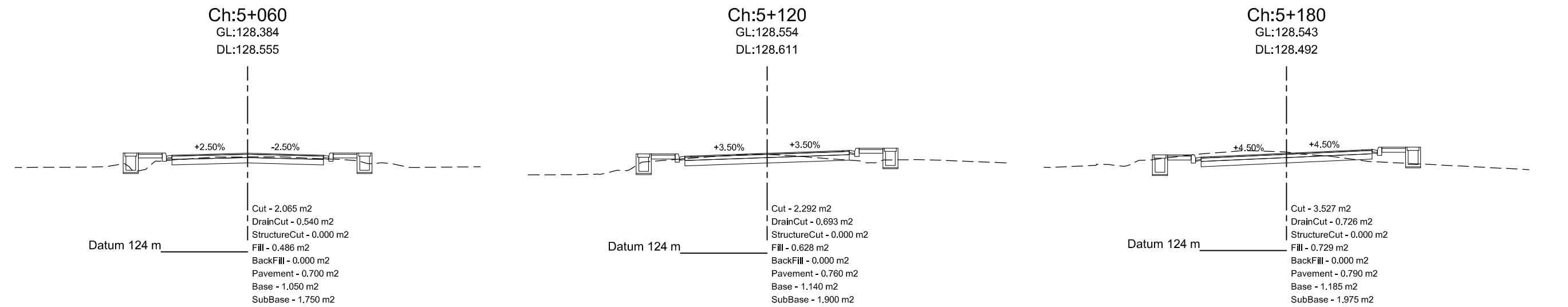
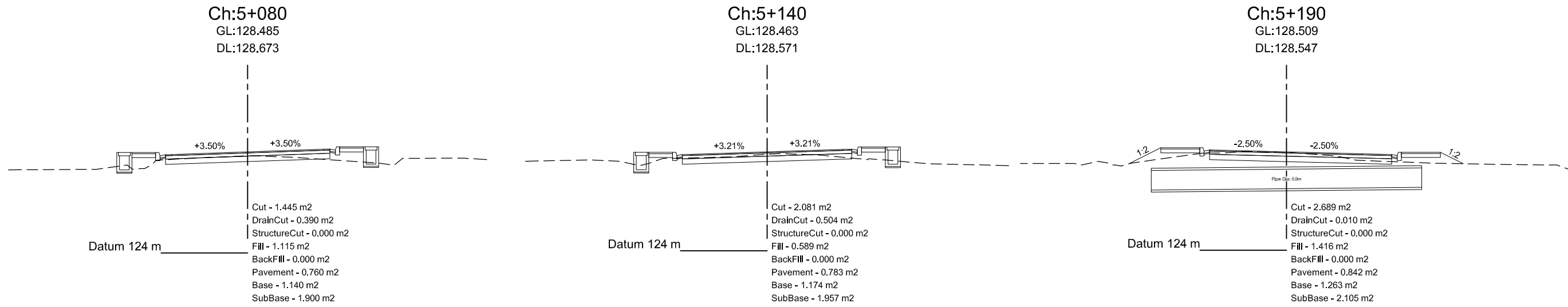

Department of Urban Development & Building Construction (DUDBC)
Regional Urban Development Project (RUDP)
West Urban Corridor (WUC) Development Project
Babarmahal, Kathmandu, Nepal

Reviewed & Designed By :
DOHWA Engineering Co. Ltd.
in Association with
ERMIC (P.) Ltd., SILT Consultants (P.) Ltd., and
DIGICON (P.) Ltd.
Mid- Baneshwor, Kathmandu
Tel: 01- 4589393

Consultant
Team Leader : YOO CHANGMIN
Reviewed By : YAGYA BAHADUR MALLA
Designed By : MANJU MUNANKARMI

Client
Approved By :
Checked By :

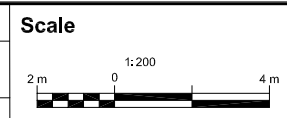

Cross-Section
BHALUHIPUL-MEDICAL COLLEGE-
BHATATOL-MUKHIYATOL-PIPARHIYA-
SINGHA-MUNICIPALITY
CH 0+000 - 7+503.82 Km

REV : MAY 2024
DRG NO : DM/RD/CS/31
CHAINAGE : 5+040-5+190
SHEET NO : 31

Ch:5+240

GL:124.155

DL:129.784

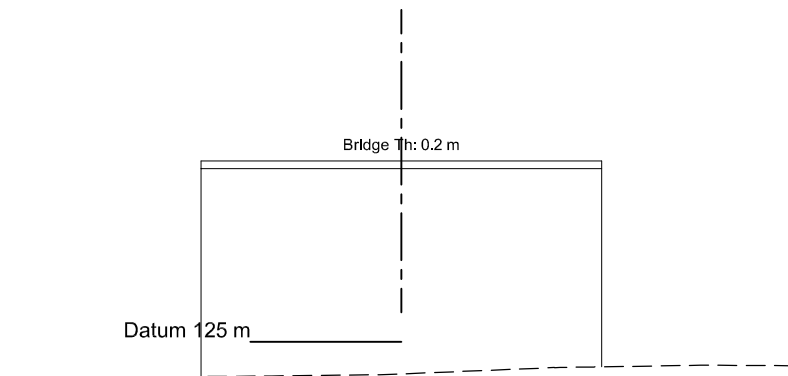

Ch:5+280

GL:129.419

DL:129.754

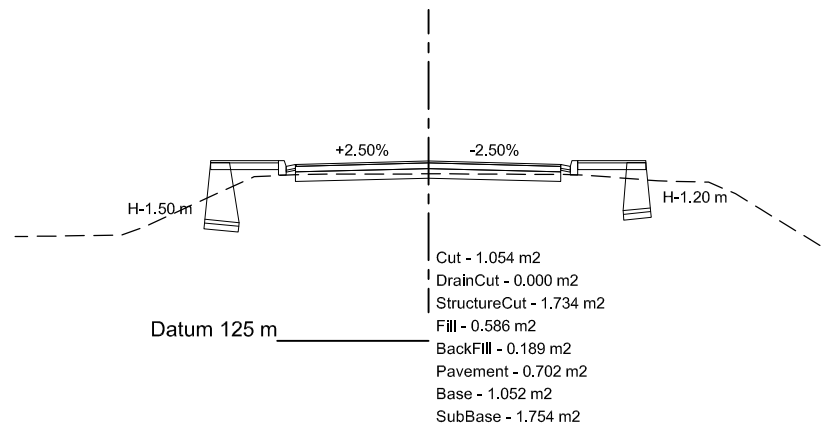

Ch:5+320

GL:128.543

DL:128.708

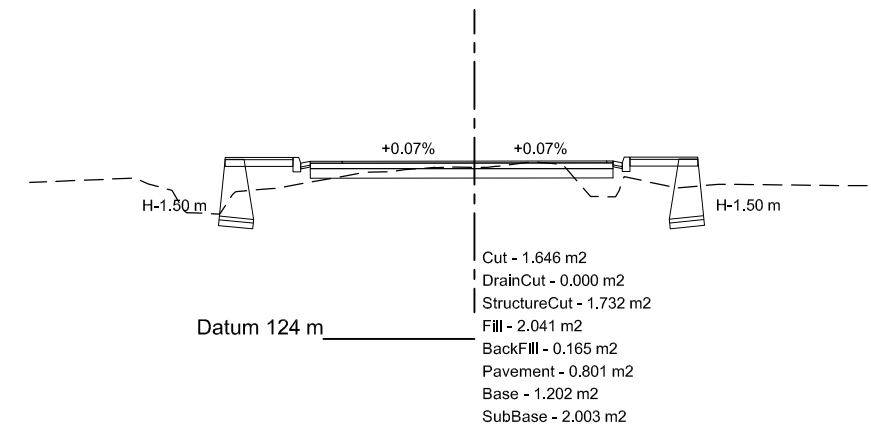

Ch:5+220

GL:129.639

DL:129.764

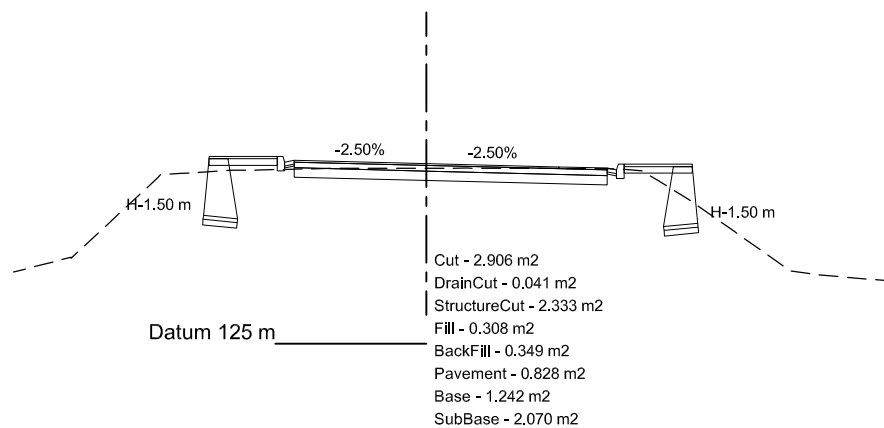

Ch:5+260

GL:124.585

DL:129.784

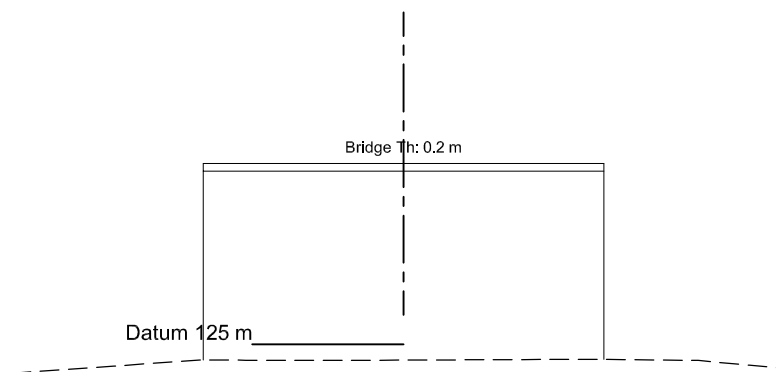

Ch:5+313

GL:128.406

DL:128.684

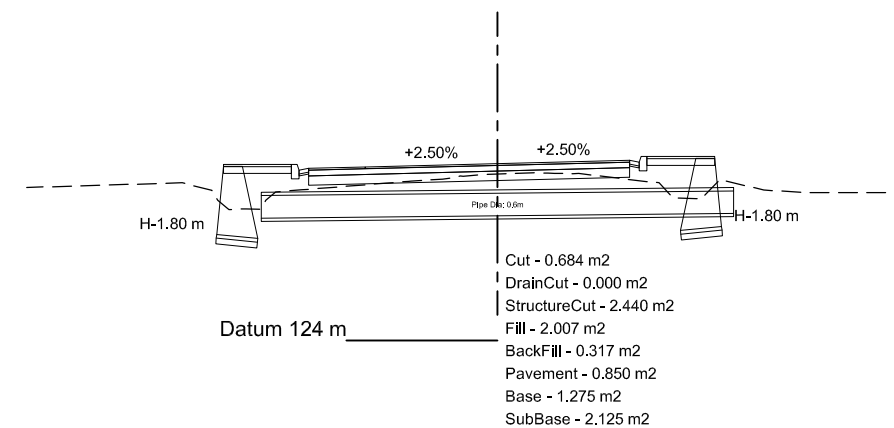

Ch:5+200

GL:128.244

DL:128.920

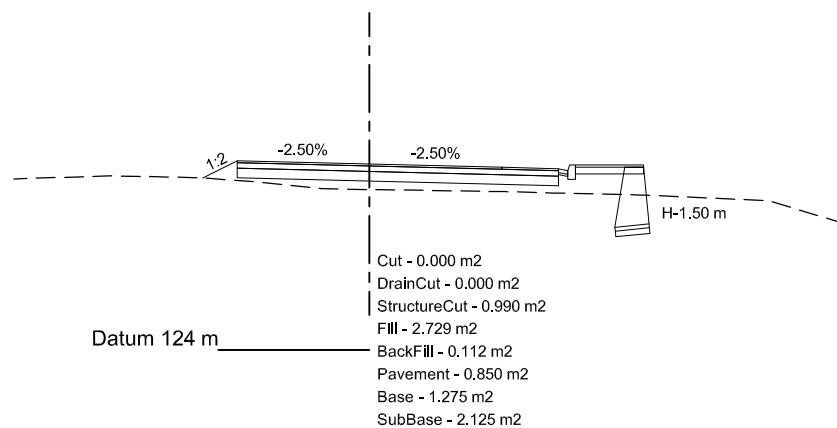

Ch:5+248

GL:124.015

DL:129.784

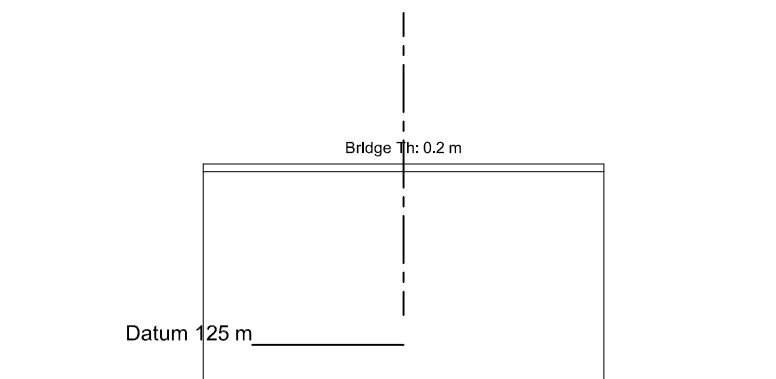

Ch:5+300

GL:128.626

DL:128.992

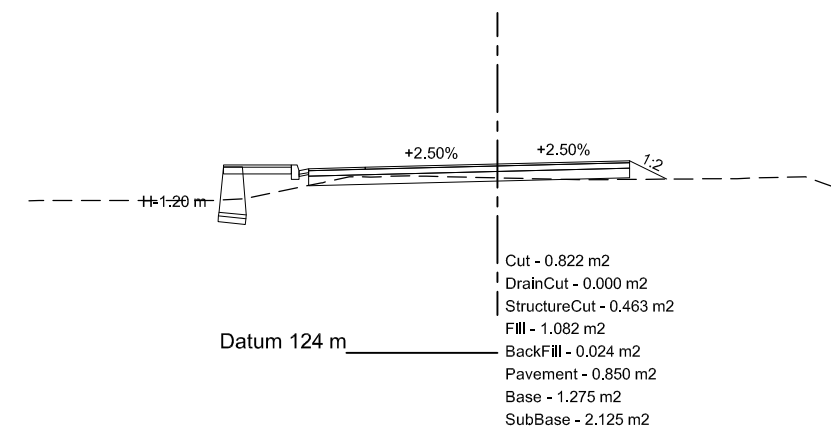

Department of Urban Development & Building
 Construction (DUDBC)
Regional Urban Development Project (RUDP)
 West Urban Corridor (WUC) Development Project
 Babarmahal, Kathmandu, Nepal

Reviewed & Designed By :
DOHWA Engineering Co. Ltd.
 in Association with
ERMIC (P.) Ltd., SILT Consultants (P.) Ltd., and
DIGICON (P.) Ltd.
 Mid-Baneshwor, Kathmandu
 Tel: 01-4589393

Consultant
Team Leader : YOO CHANGMIN
Reviewed By : YAGYA BAHADUR MALLA
Designed By : MANJU MUNANKARMI

Client
Approved By :
Checked By :

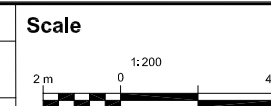

Cross-Section
BHALUHIPUL-MEDICAL COLLEGE-
BHATATOL-MUKHIYATOL-PIPARHIYA-
SINGHA-MUNICIPALITY
CH 0+000 - 7+503.82 Km

REV : MAY 2024
DRG NO : DM/RD/CS/32
CHAINAGE : 5+200-5+320
SHEET NO : 32

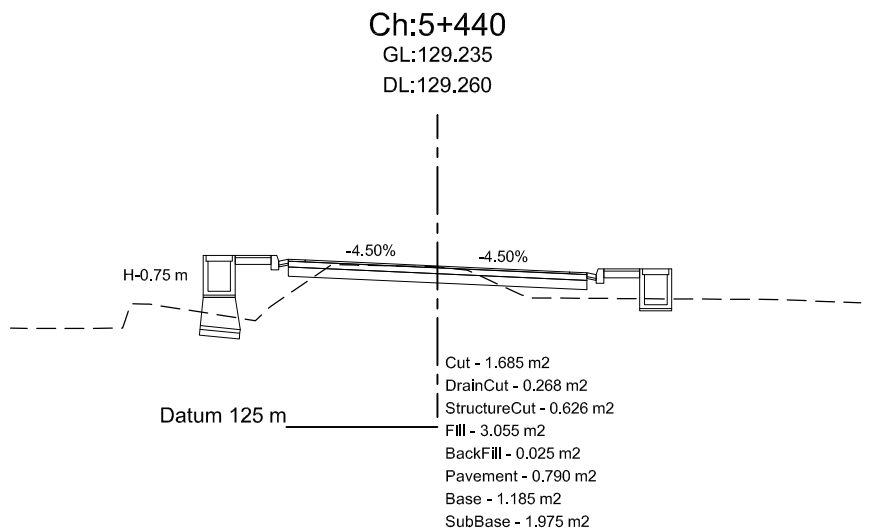
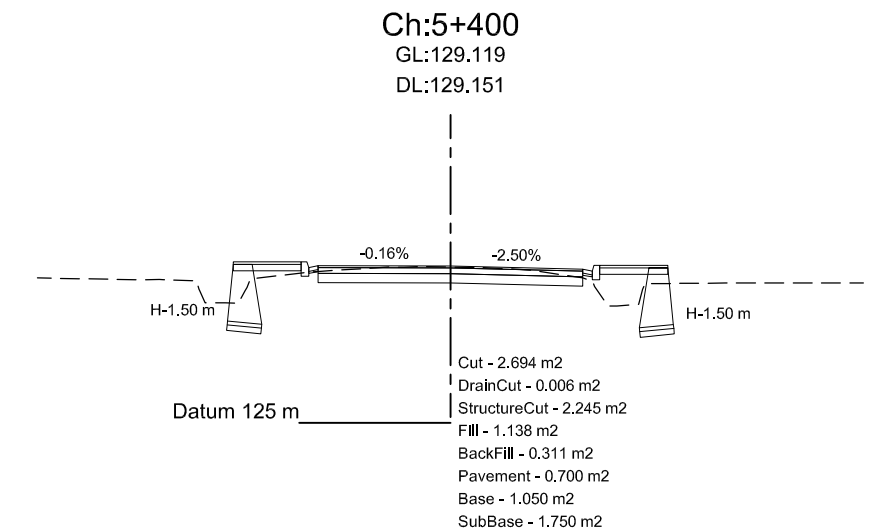
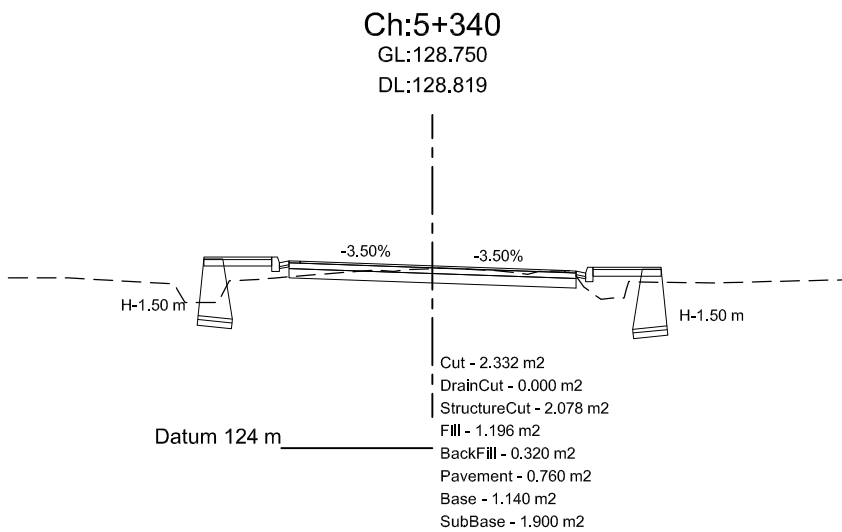
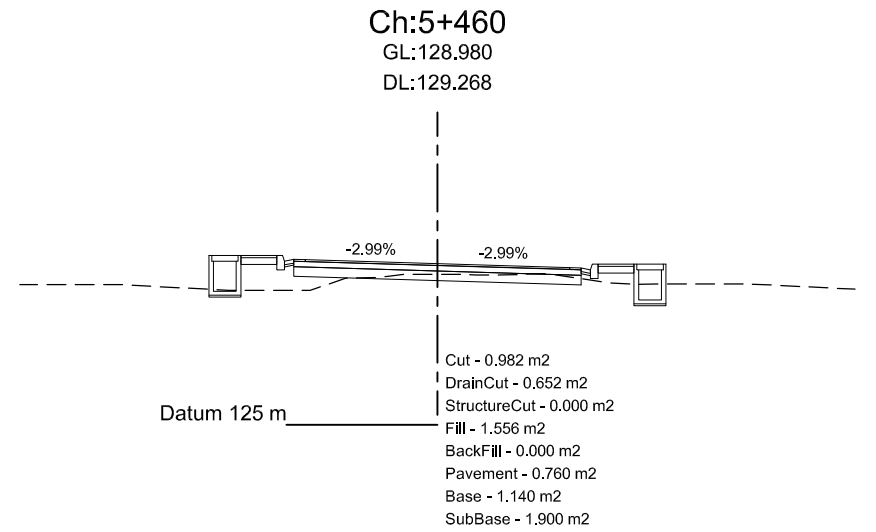
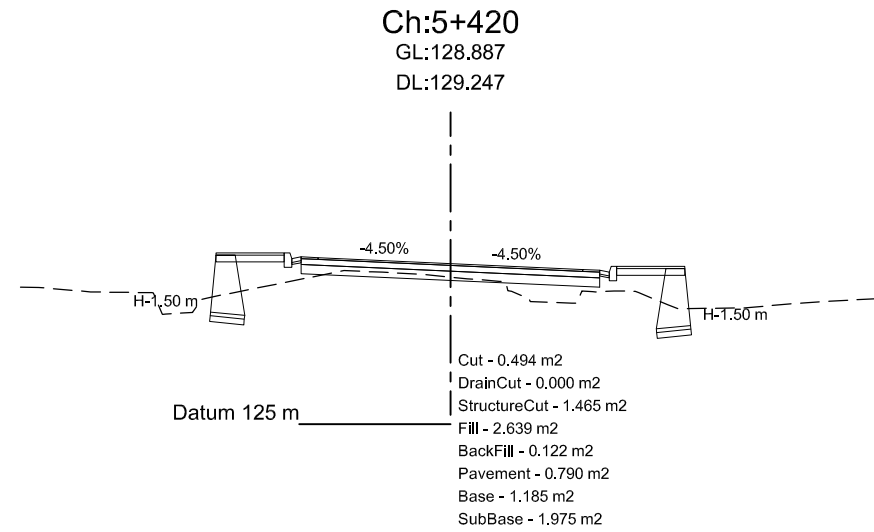
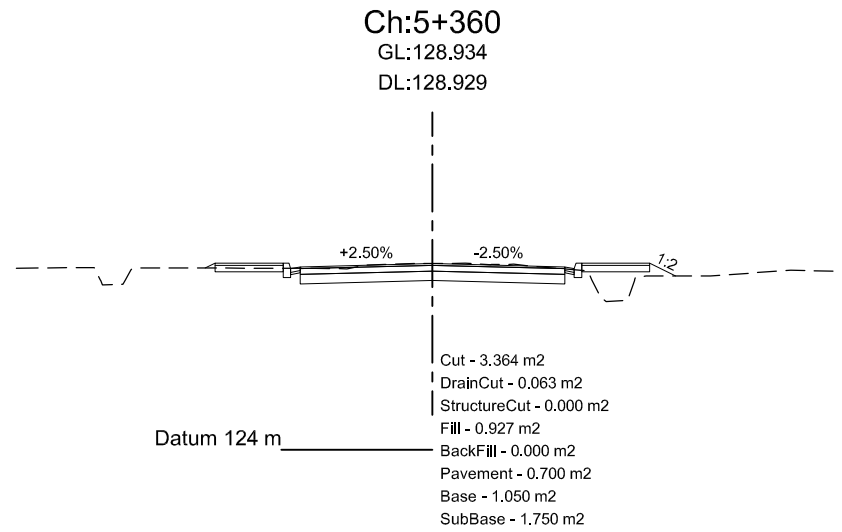
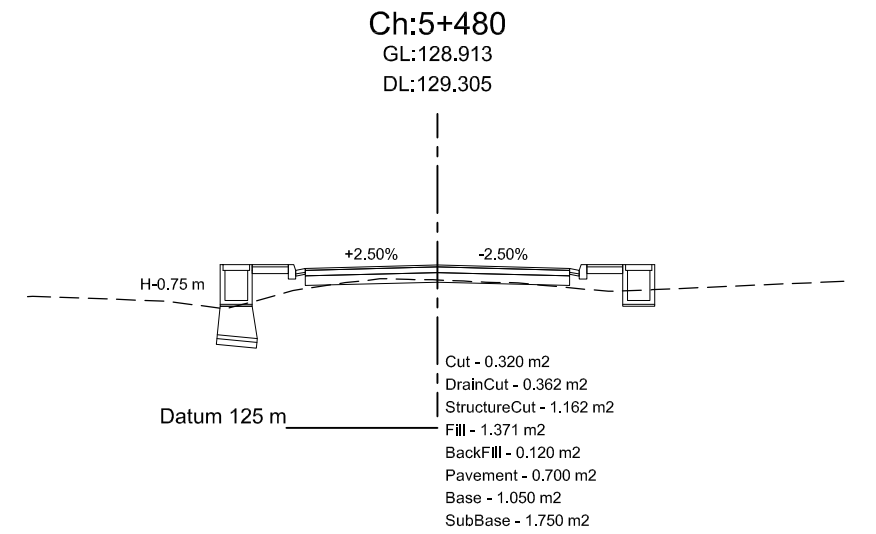
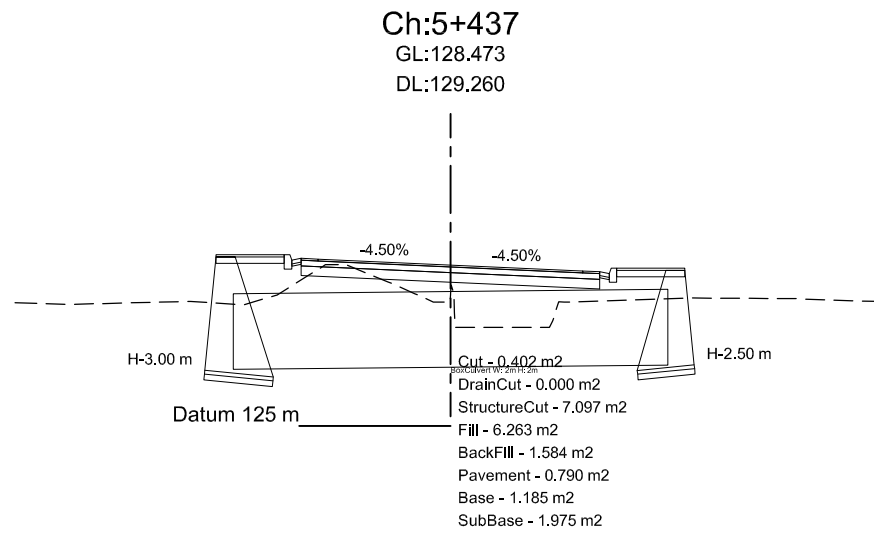
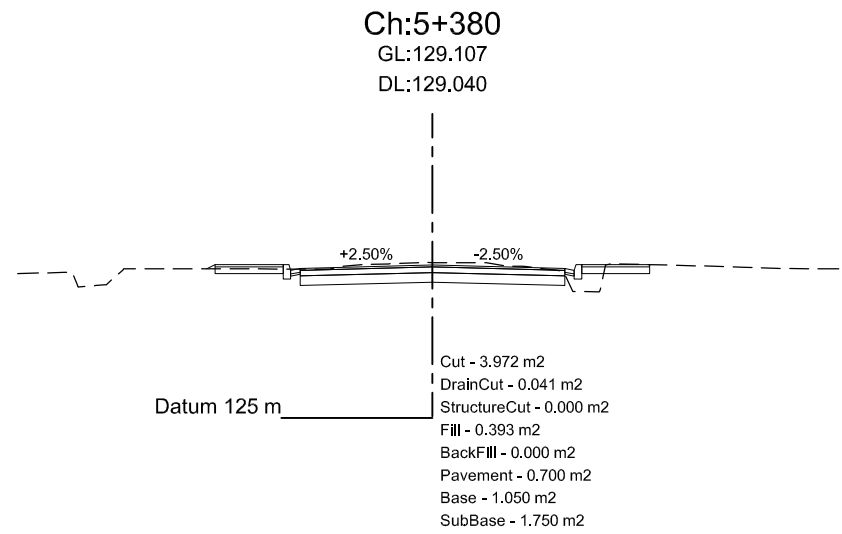

Department of Urban Development & Building Construction (DUDBC)
Regional Urban Development Project (RUDP)
West Urban Corridor (WUC) Development Project
Babarmahal, Kathmandu, Nepal

Reviewed & Designed By :
DOHWA Engineering Co. Ltd.
in Association with
ERMIC (P.) Ltd., SILT Consultants (P.) Ltd., and
DIGICON (P.) Ltd.
Mid- Baneshwor, Kathmandu
Tel: 01- 4589393

Consultant
Team Leader : YOO CHANGMIN
Reviewed By : YAGYA BAHADUR MALLA
Designed By : MANJU MUNANKARMI

Client
Approved By :
Checked By :

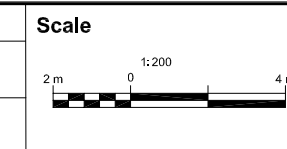

Cross-Section
BHALUHIPUL-MEDICAL COLLEGE-
BHATATOL-MUKHIYATOL-PIPARHIYA-
SINGHA-MUNICIPALITY
CH 0+000 - 7+503.82 Km

REV : MAY 2024
DRG NO : DM/RD/CS/33
CHAINAGE : 5+340-5+480
SHEET NO : 33

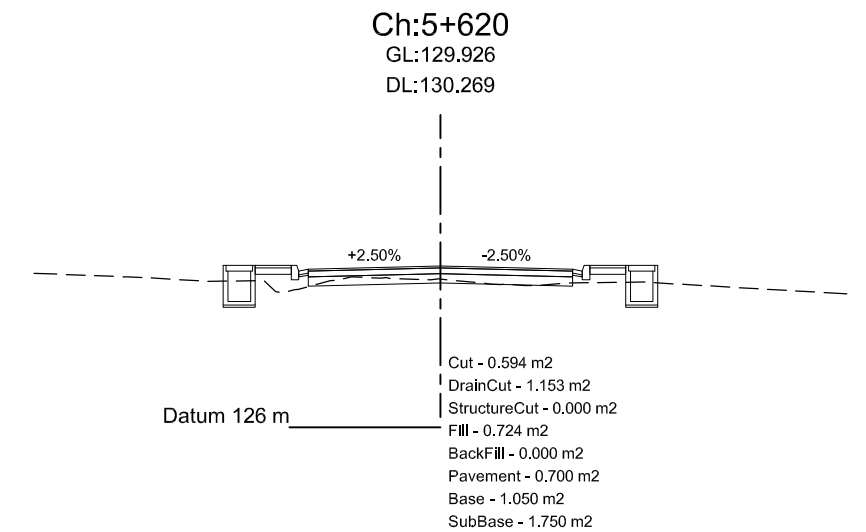
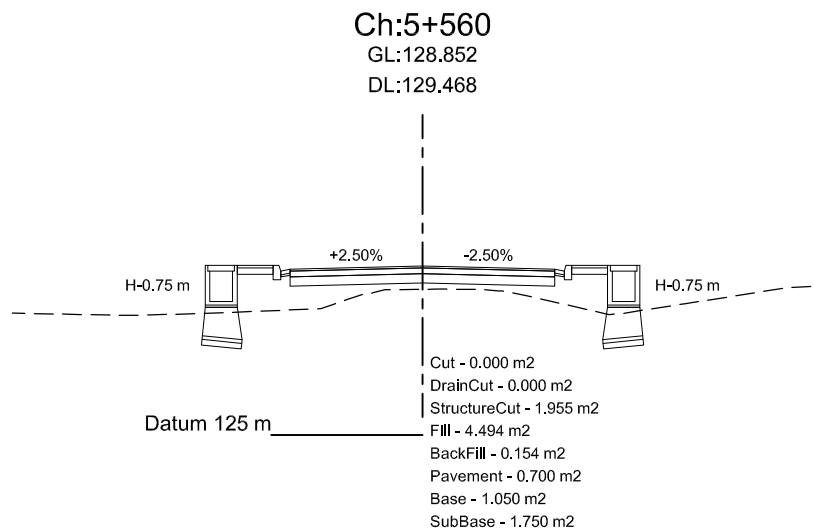
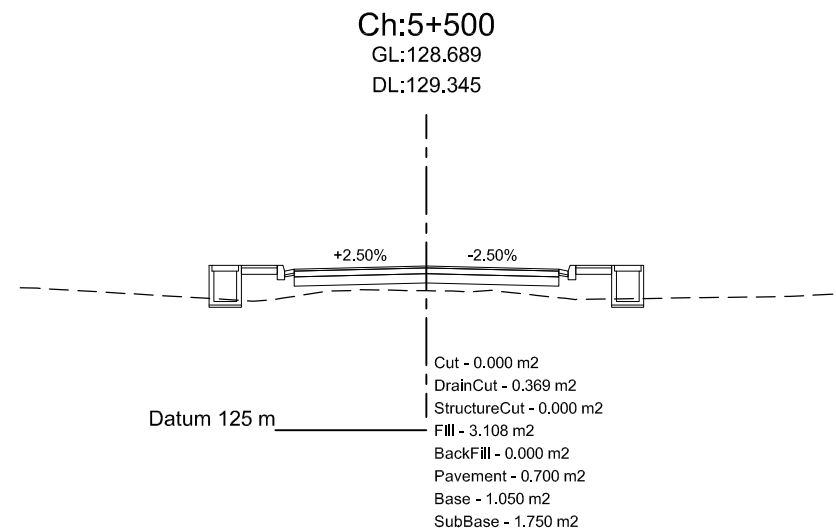
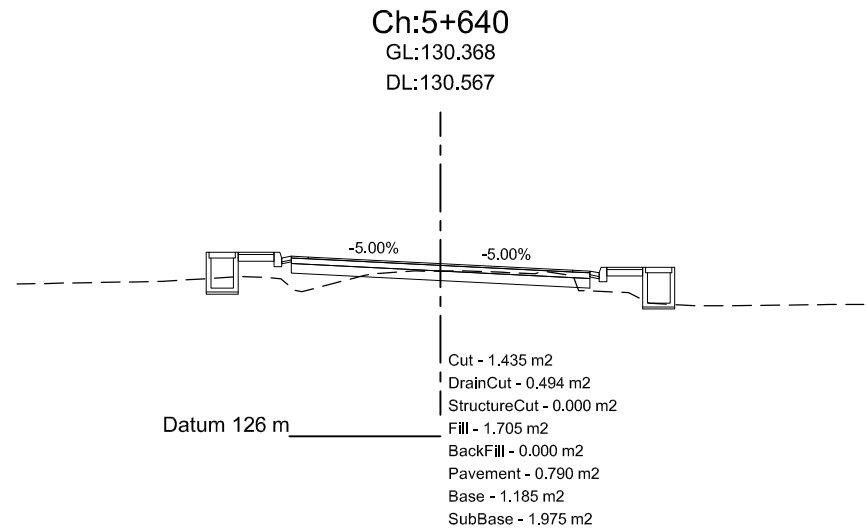
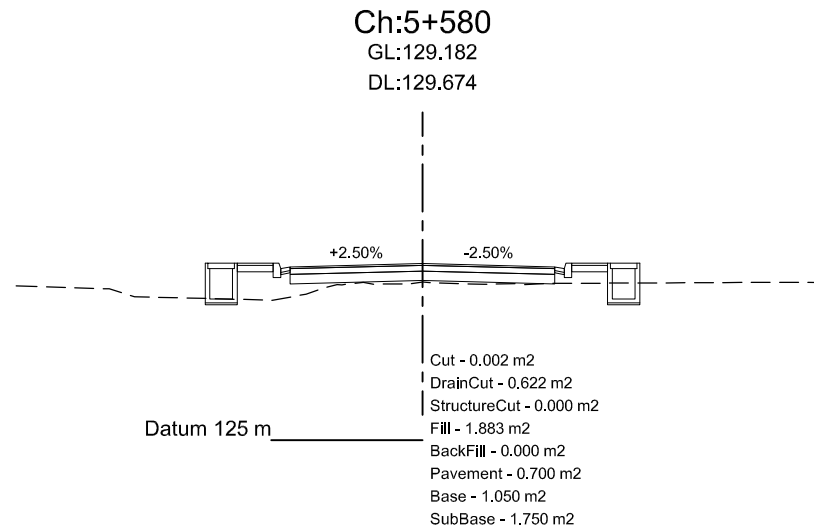
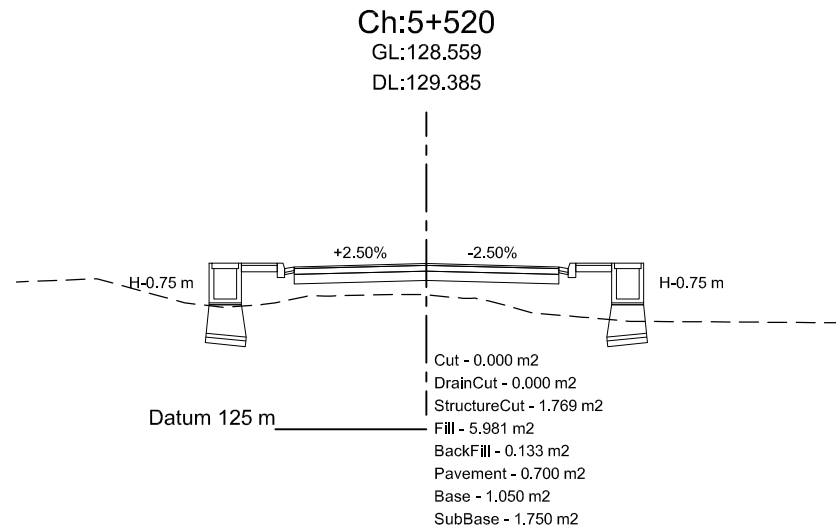
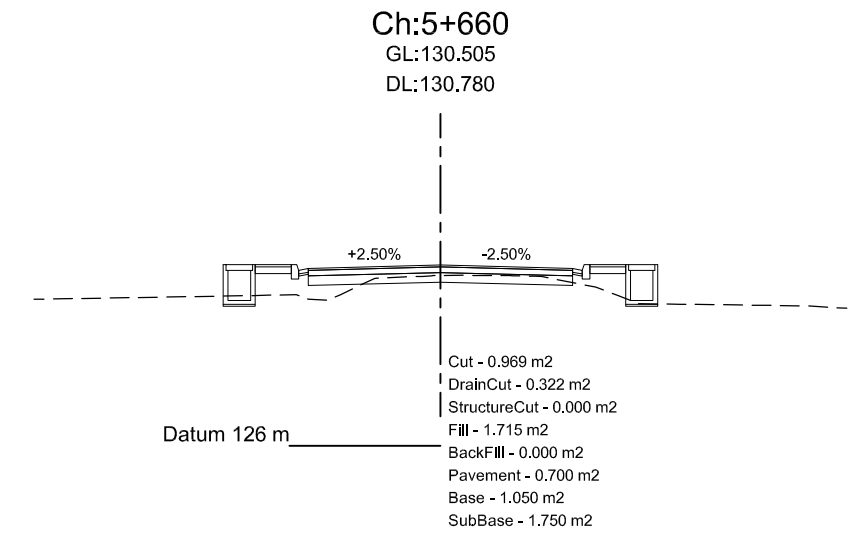
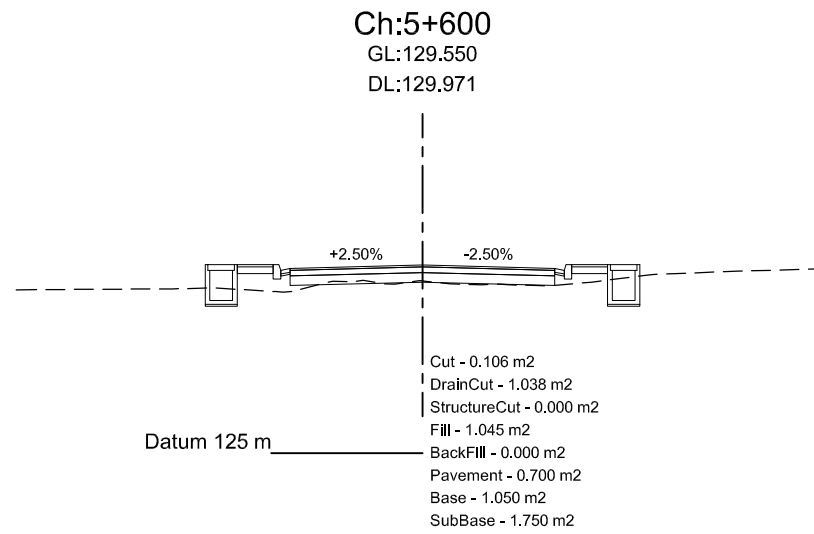
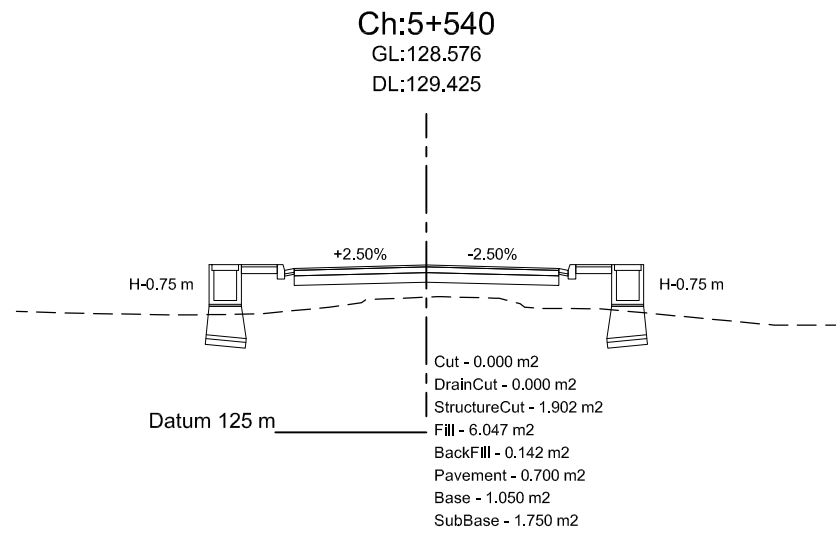

Department of Urban Development & Building
Construction (DUDBC)
Regional Urban Development Project (RUDP)
West Urban Corridor (WUC) Development Project
Babarmahal, Kathmandu, Nepal

Reviewed & Designed By :
DOHWA Engineering Co. Ltd.
in Association with
ERMIC (P.) Ltd., SILT Consultants (P.) Ltd., and
DIGICON (P.) Ltd.
Mid- Baneshwor, Kathmandu
Tel: 01- 4589393

Consultant
Team Leader : YOO CHANGMIN
Reviewed By : YAGYA BAHADUR MALLA
Designed By : MANJU MUNANKARMI

Client
Approved By :
Checked By :

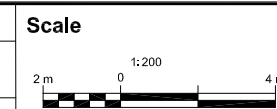

Cross-Section
BHALUHIPUL-MEDICAL COLLEGE-
BHATATOL-MUKHIYATOL-PIPARHIYA-
SINGHA-MUNICIPALITY
CH 0+000 - 7+503.82 Km

REV : MAY 2024
DRG NO : DM/RD/CS/34
CHAINAGE : 5+500-5+660
SHEET NO : 34

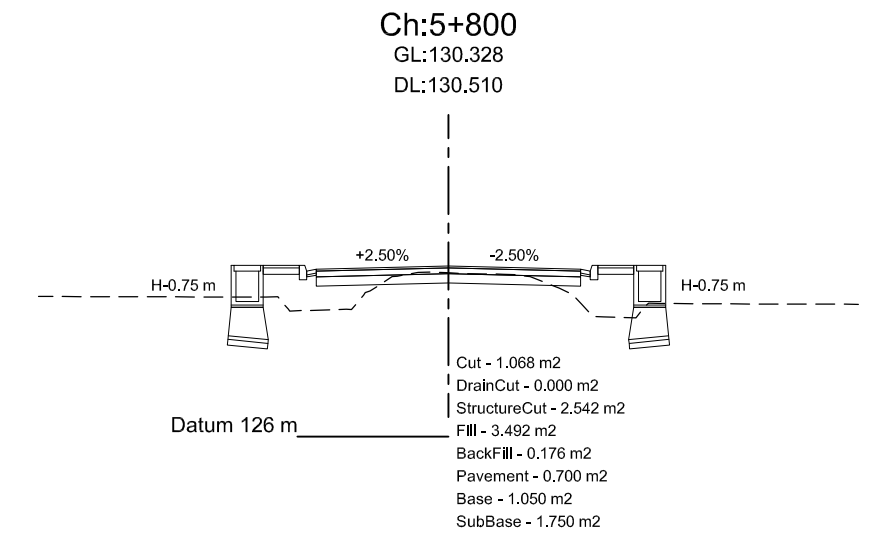
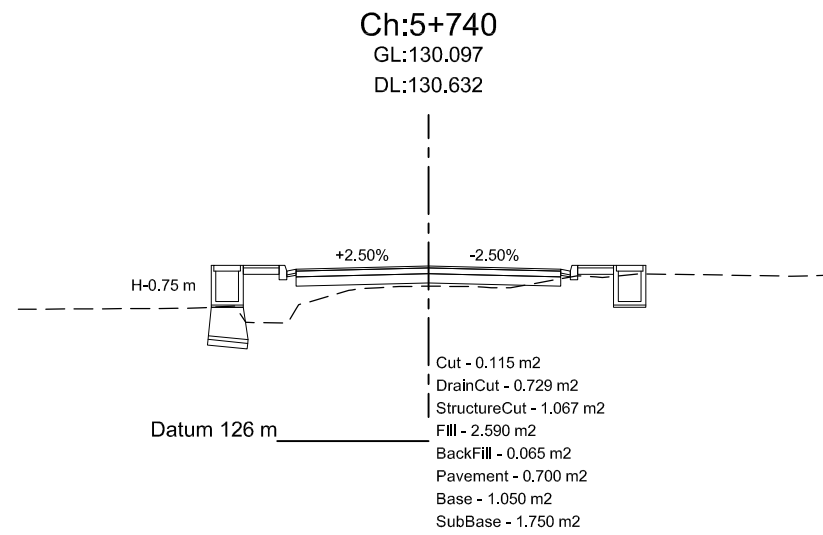
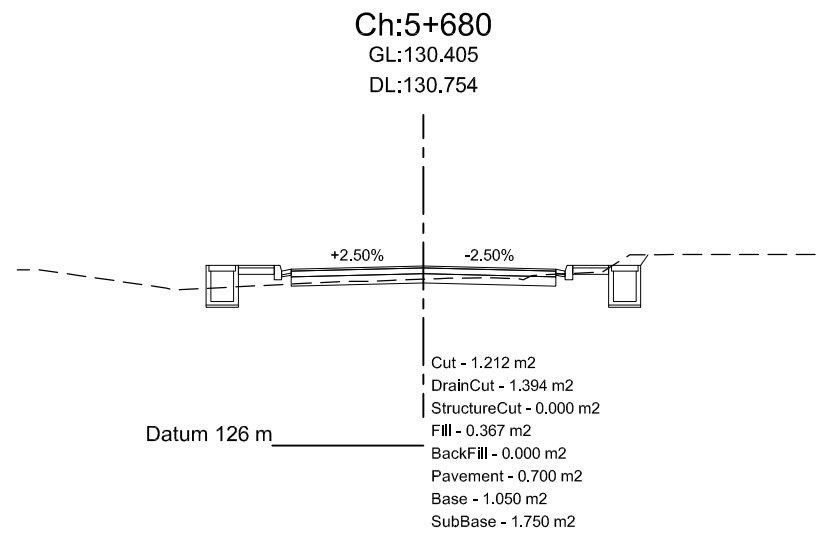
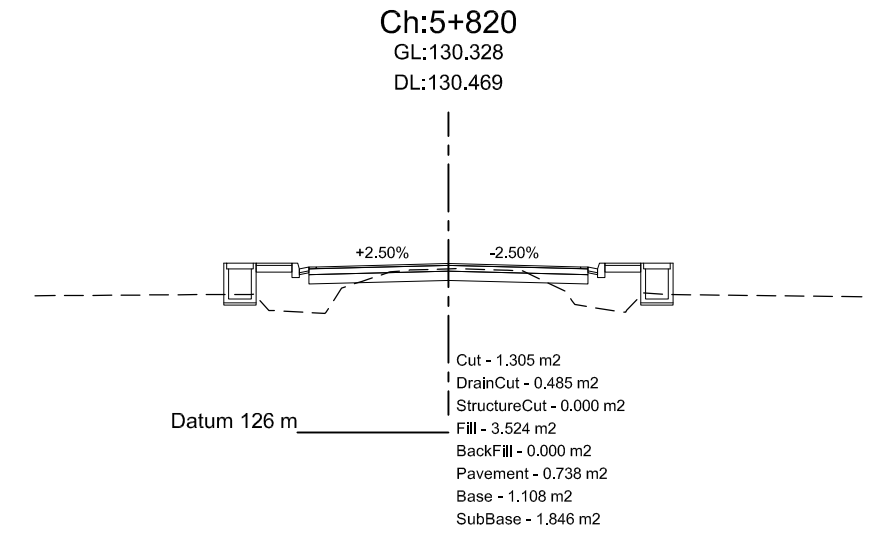
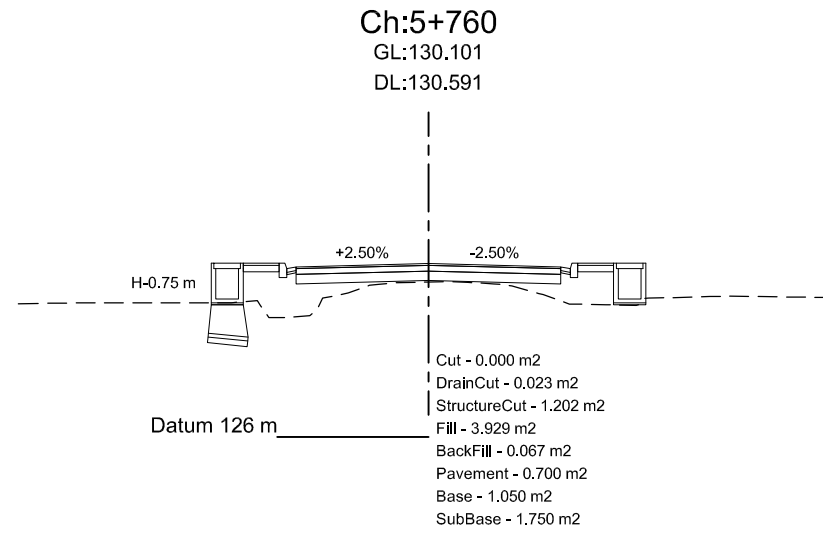
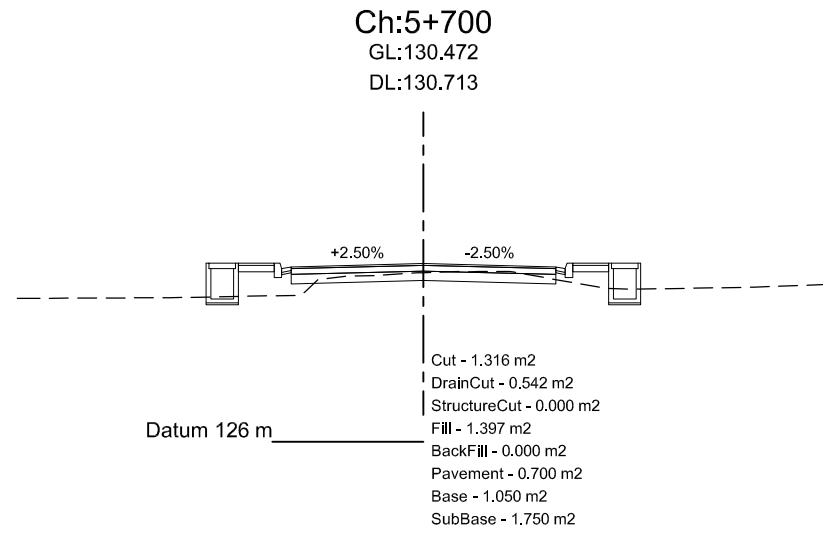
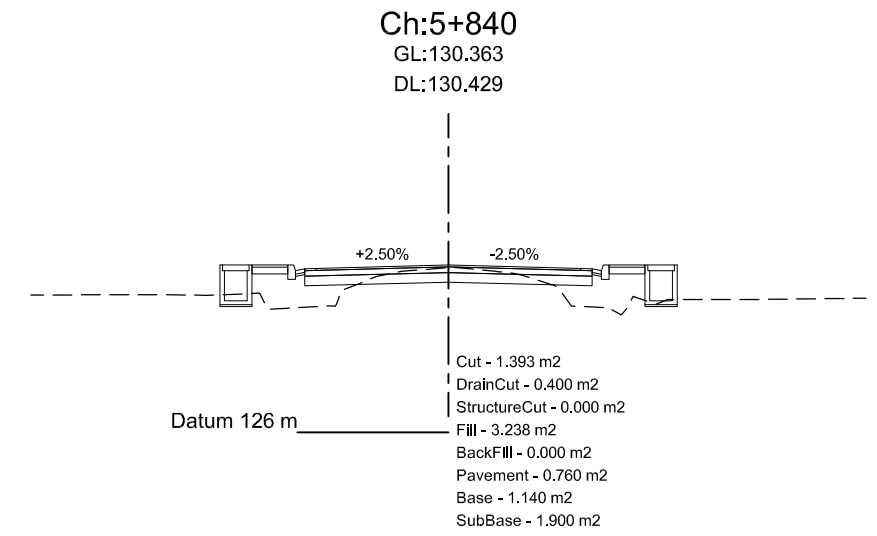
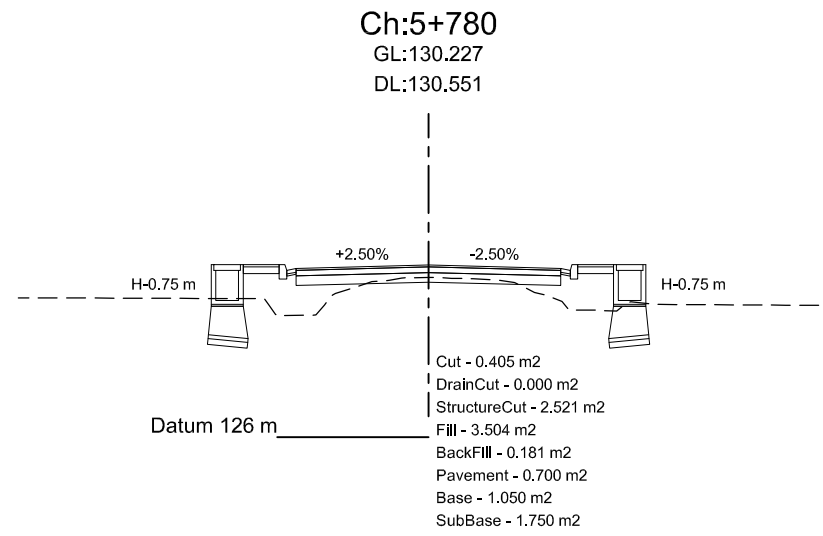
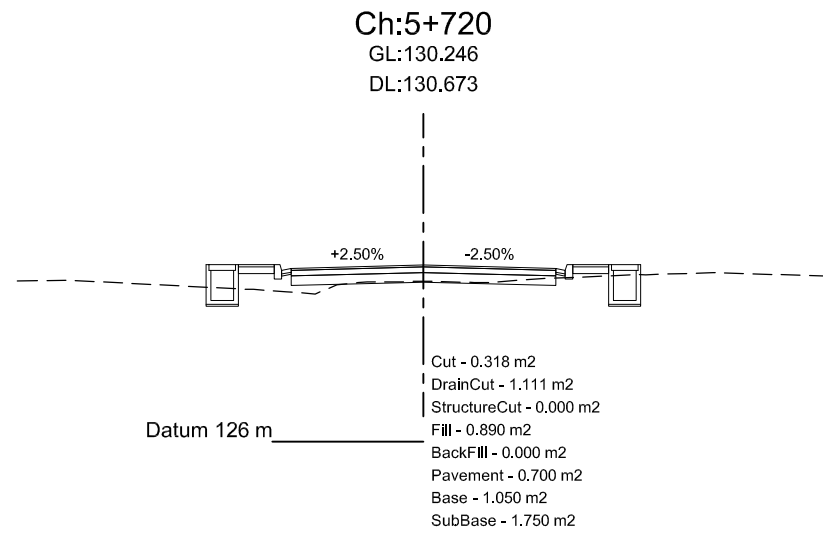

Department of Urban Development & Building
Construction (DUDBC)
Regional Urban Development Project (RUDP)
West Urban Corridor (WUC) Development Project
Babarmahal, Kathmandu, Nepal

Reviewed & Designed By :
DOHWA Engineering Co. Ltd.
in Association with
ERMIC (P.) Ltd., SILT Consultants (P.) Ltd., and
DIGICON (P.) Ltd.
Mid- Baneshwor, Kathmandu
Tel: 01- 4589393

Consultant
Team Leader : YOO CHANGMIN
Reviewed By : YAGYA BAHADUR MALLA
Designed By : MANJU MUNANKARMI

Client
Approved By :
Checked By :

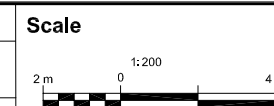

Cross-Section
BHALUHIPUL-MEDICAL COLLEGE-
BHATATOL-MUKHIYATOL-PIPARHIYA-
SINGHA-MUNICIPALITY
CH 0+000 - 7+503.82 Km

REV : MAY 2024
DRG NO : DM/RD/CS/35
CHAINAGE : 5+680-5+840
SHEET NO : 35

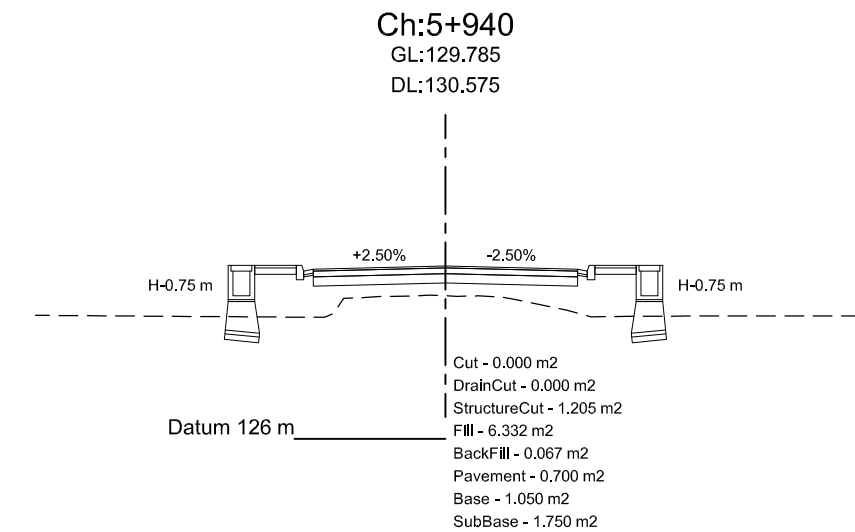
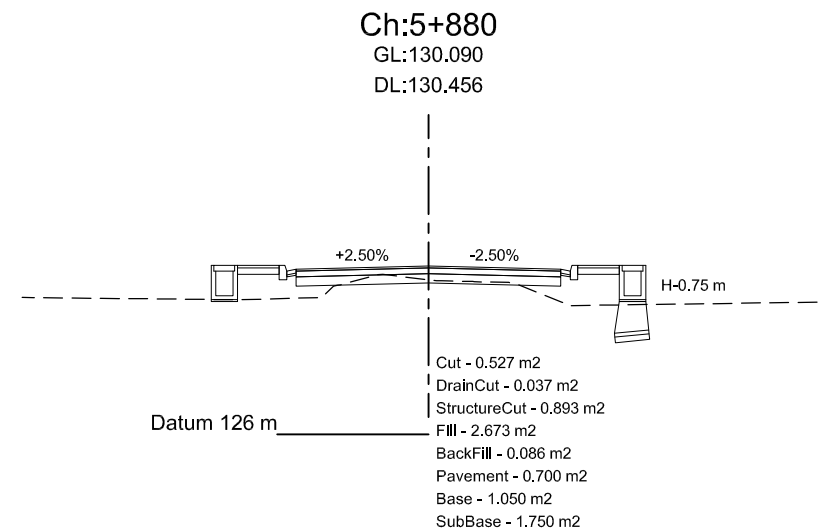
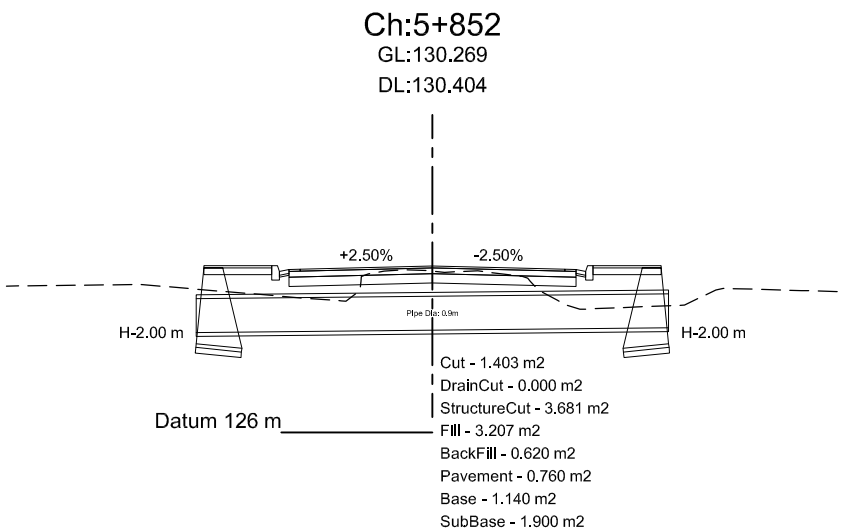
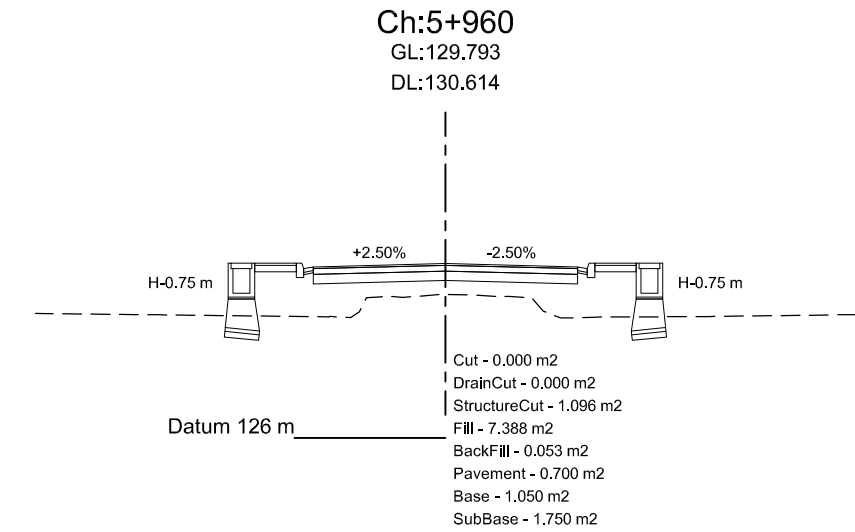
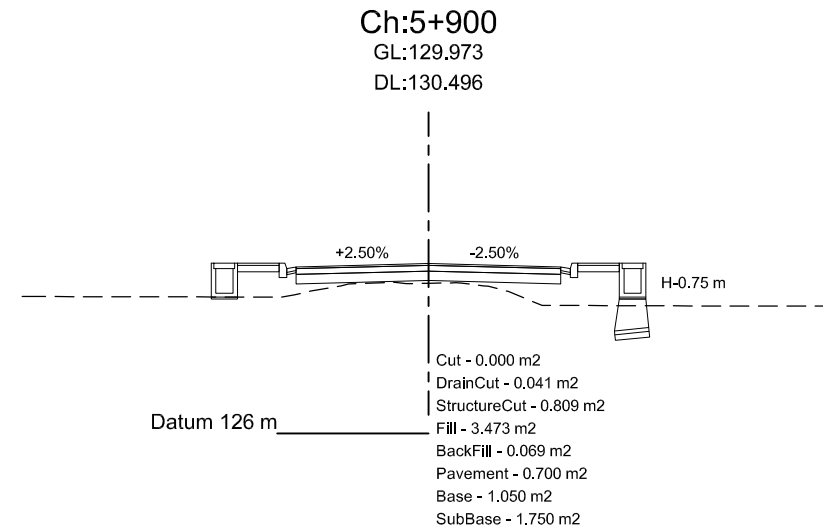
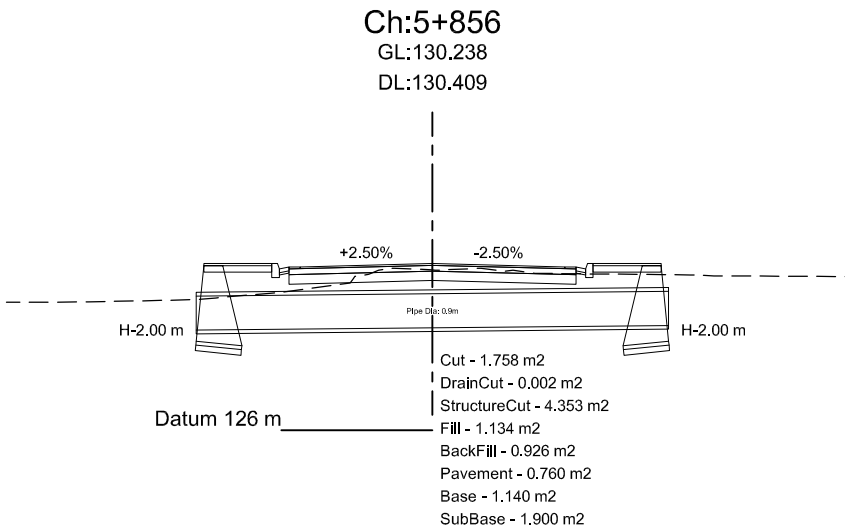
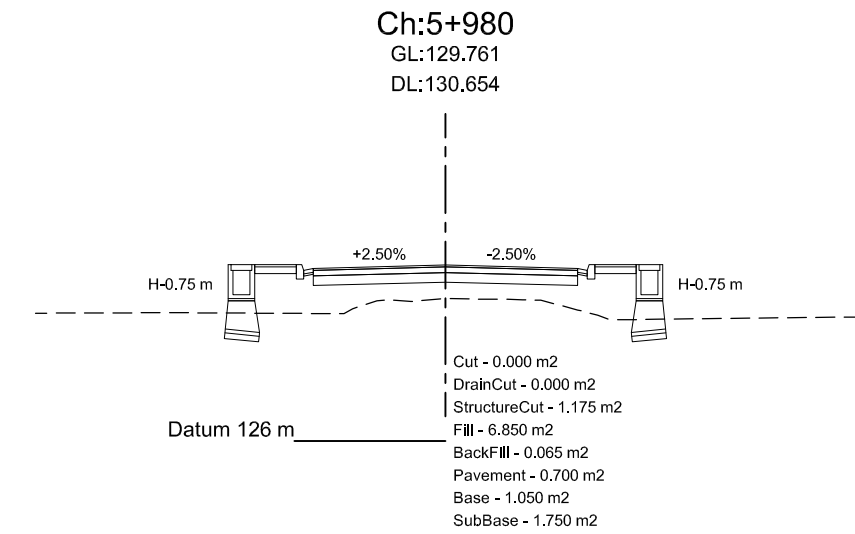
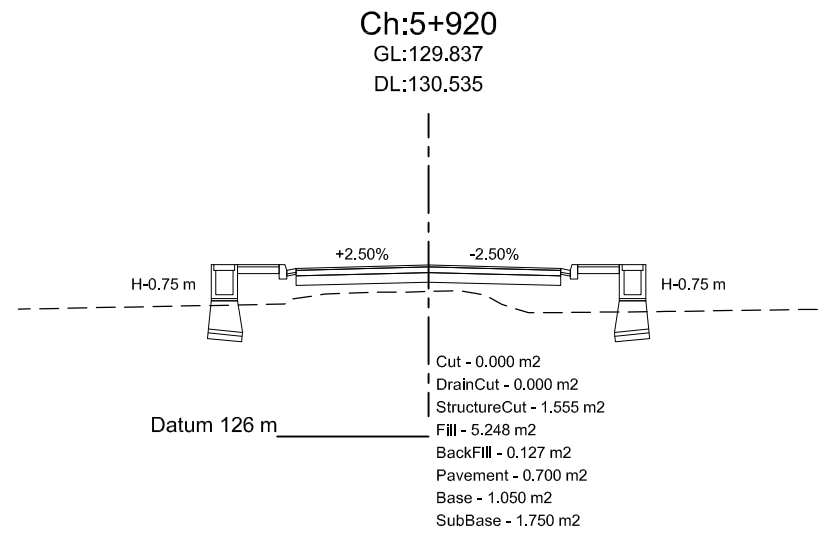
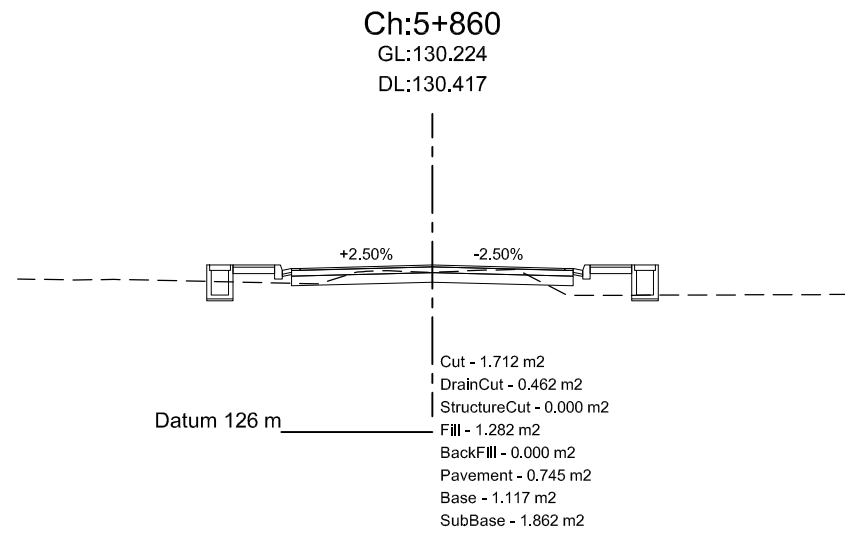

Department of Urban Development & Building Construction (DUDBC)
Regional Urban Development Project (RUDP)
West Urban Corridor (WUC) Development Project
Babarmahal, Kathmandu, Nepal

Reviewed & Designed By :
DOHWA Engineering Co. Ltd.
in Association with
ERMIC (P.) Ltd., SILT Consultants (P.) Ltd., and
DIGICON (P.) Ltd.
Mid-Baneshwor, Kathmandu
Tel: 01-4589393

Consultant
Team Leader : YOO CHANGMIN
Reviewed By : YAGYA BAHADUR MALLA
Designed By : MANJU MUNANKARMI

Client
Approved By :
Checked By :

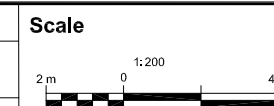

Cross-Section
BHALUHIPUL-MEDICAL COLLEGE-
BHATATOL-MUKHIYATOL-PIPARHIYA-
SINGHA-MUNICIPALITY
CH 0+000 - 7+503.82 Km

REV : MAY 2024
DRG NO : DM/RD/CS/36
CHAINAGE : 5+852-5+980
SHEET NO : 36

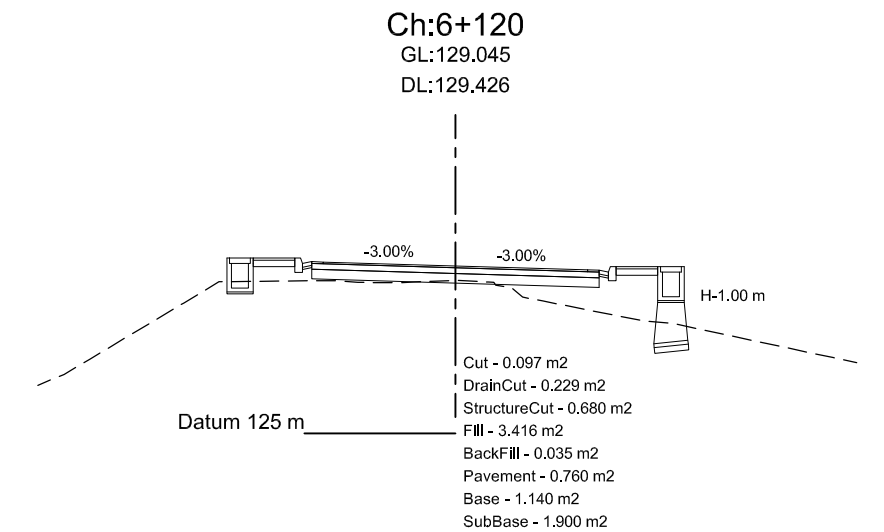
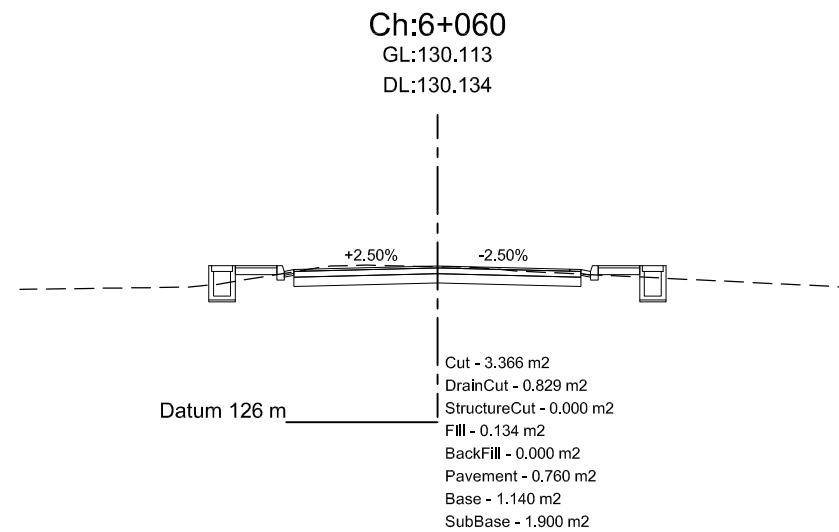
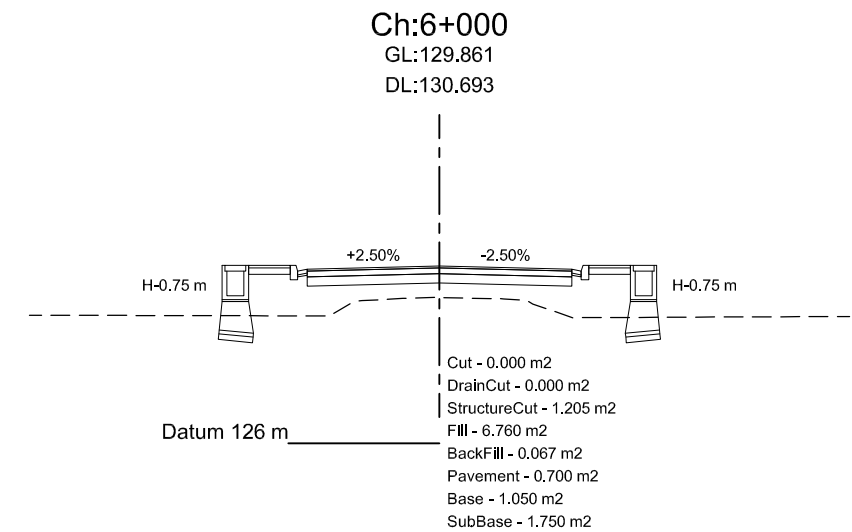
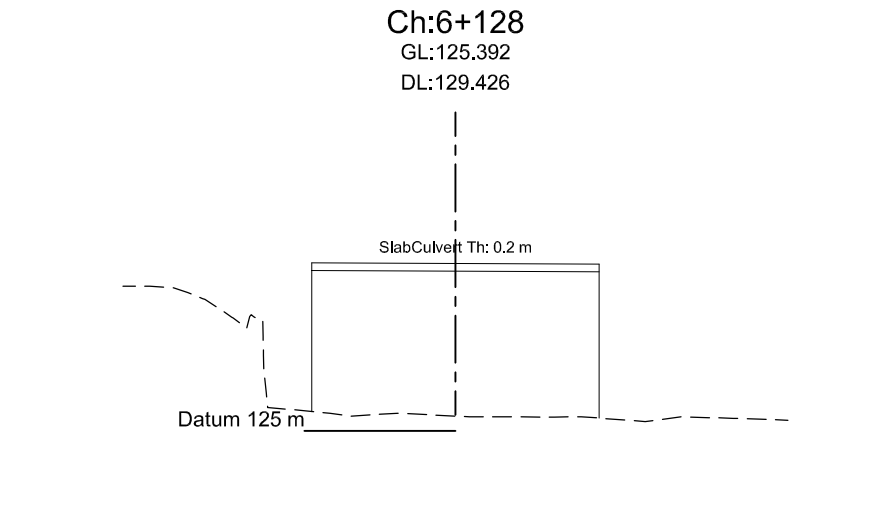
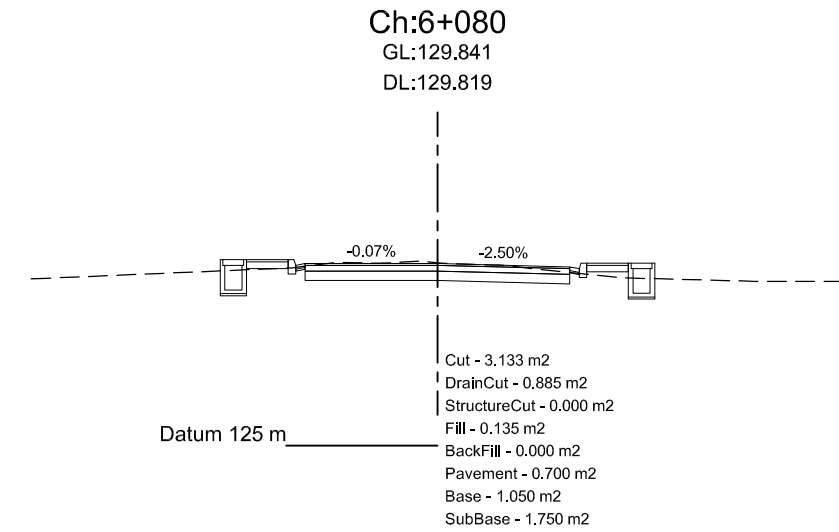
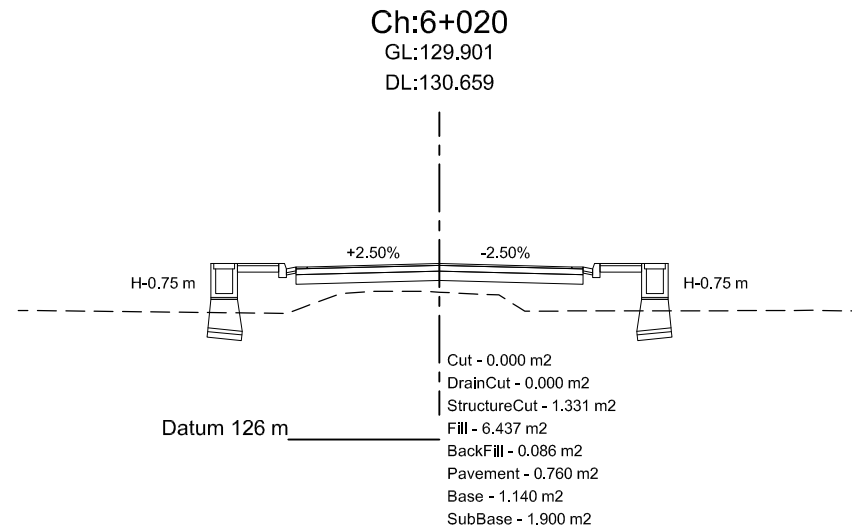
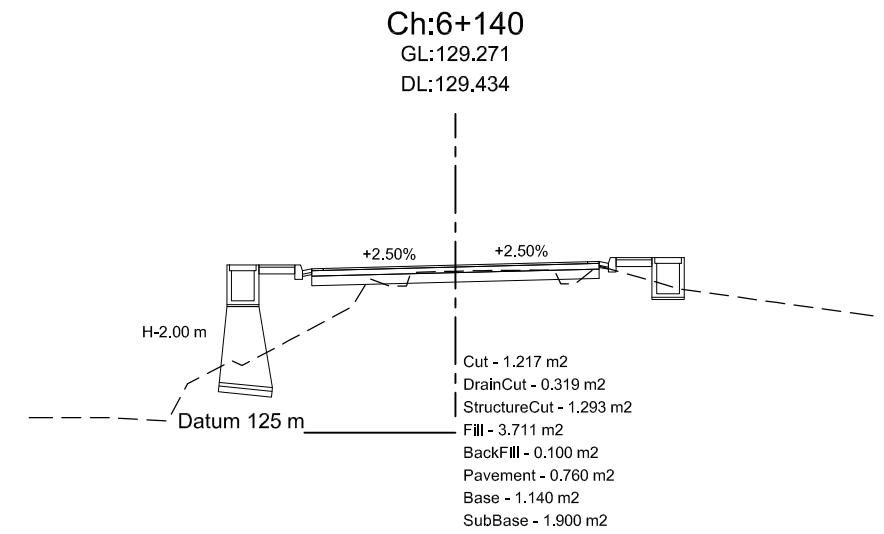
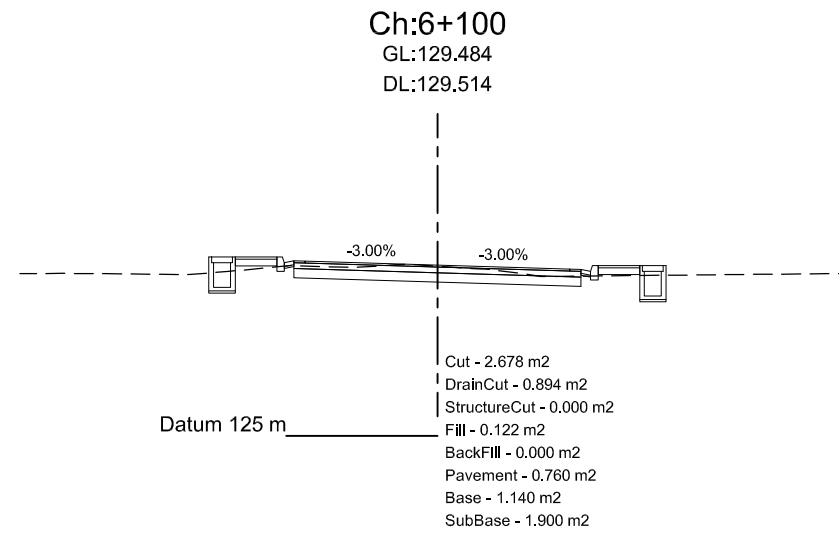
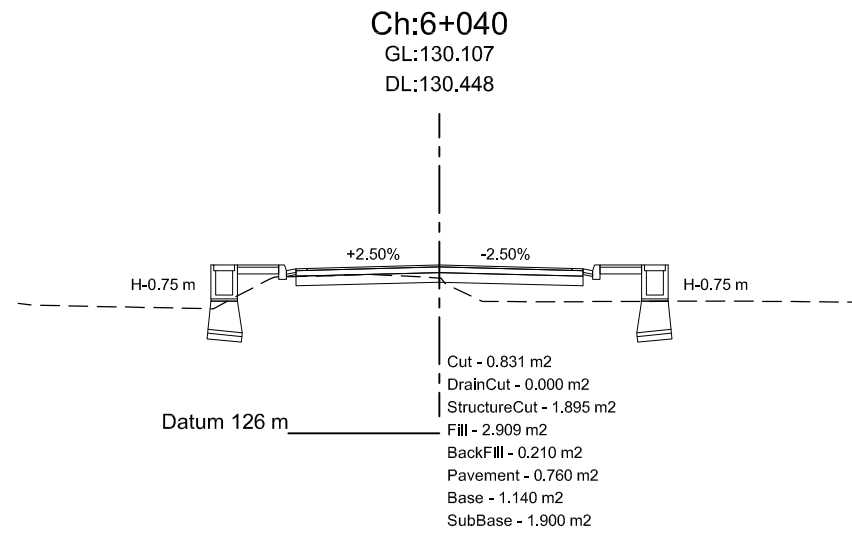

Department of Urban Development & Building Construction (DUDBC)
Regional Urban Development Project (RUDP)
West Urban Corridor (WUC) Development Project
Babarmahal, Kathmandu, Nepal

Reviewed & Designed By :
DOHWA Engineering Co. Ltd.
in Association with
ERMIC (P.) Ltd., SILT Consultants (P.) Ltd., and
DIGICON (P.) Ltd.
Mid- Baneshwor, Kathmandu
Tel: 01- 4589393

Consultant
Team Leader : YOO CHANGMIN
Reviewed By : YAGYA BAHADUR MALLA
Designed By : MANJU MUNANKARMI

Client
Approved By :
Checked By :

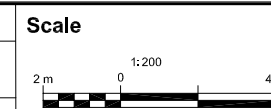

Cross-Section
BHALUHIPUL-MEDICAL COLLEGE-
BHATATOL-MUKHIYATOL-PIPARHIYA-
SINGHA-MUNICIPALITY
CH 0+000 - 7+503.82 Km

REV : MAY 2024
DRG NO : DM/RD/CS/37
CHAINAGE : 6+000-6+140
SHEET NO : 37

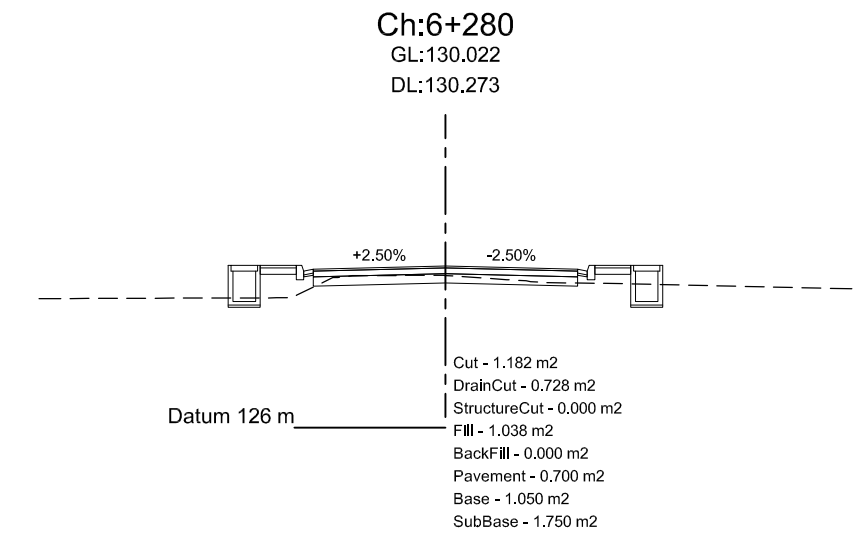
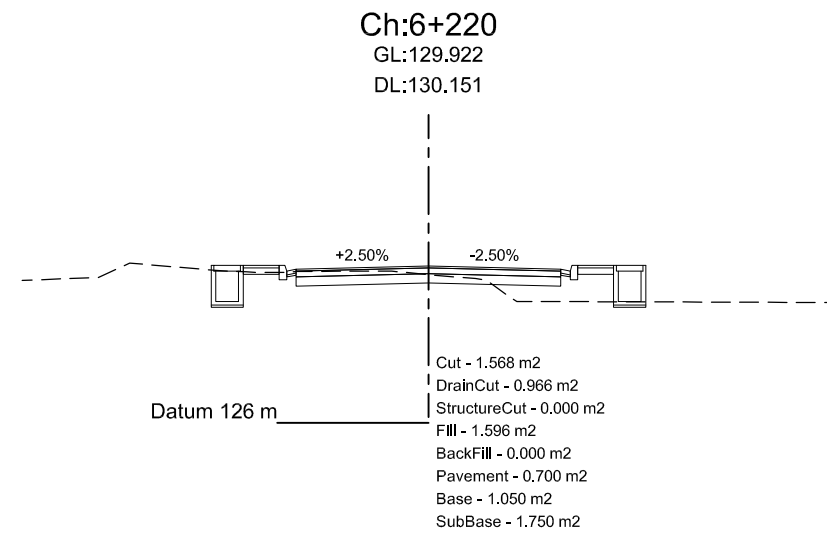
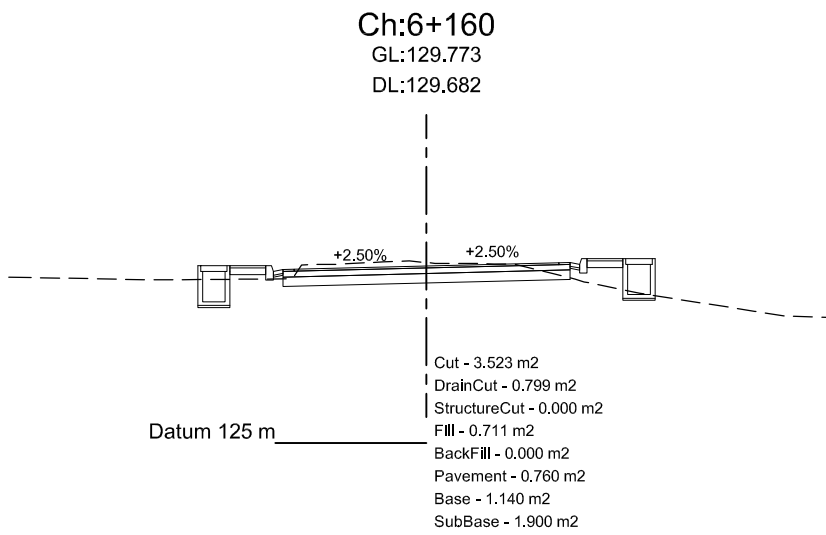
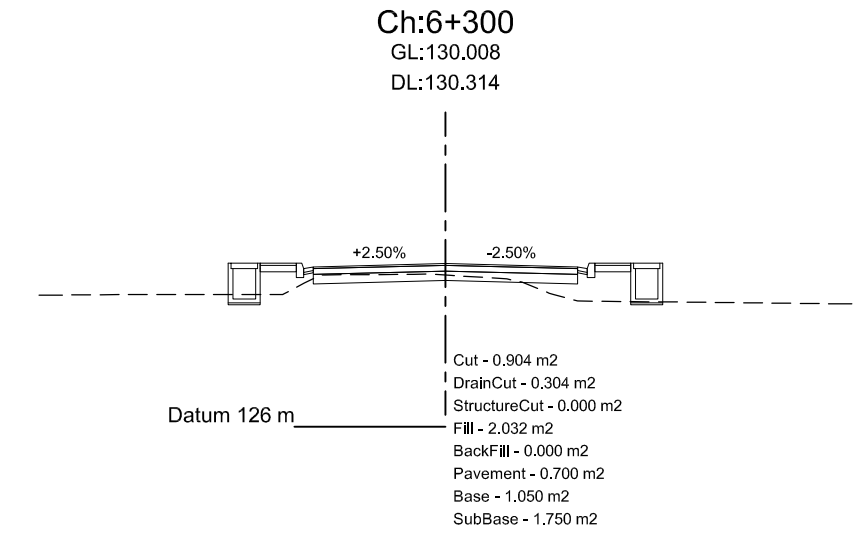
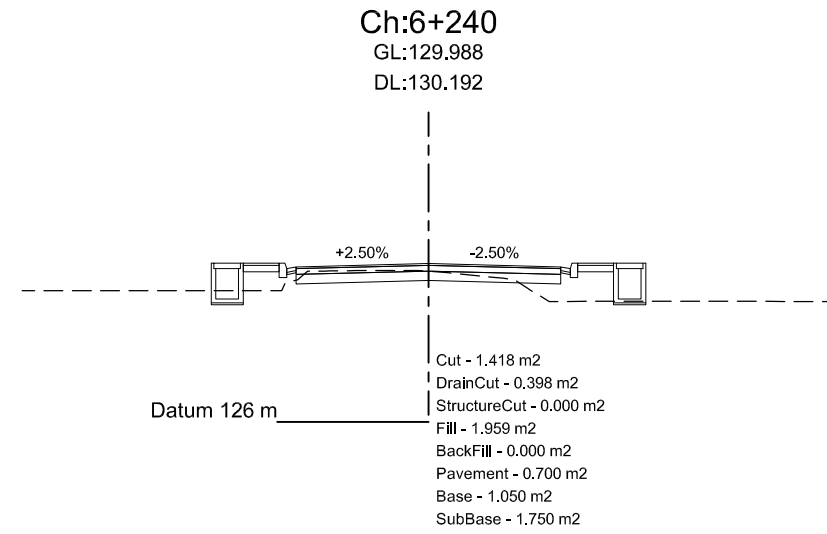
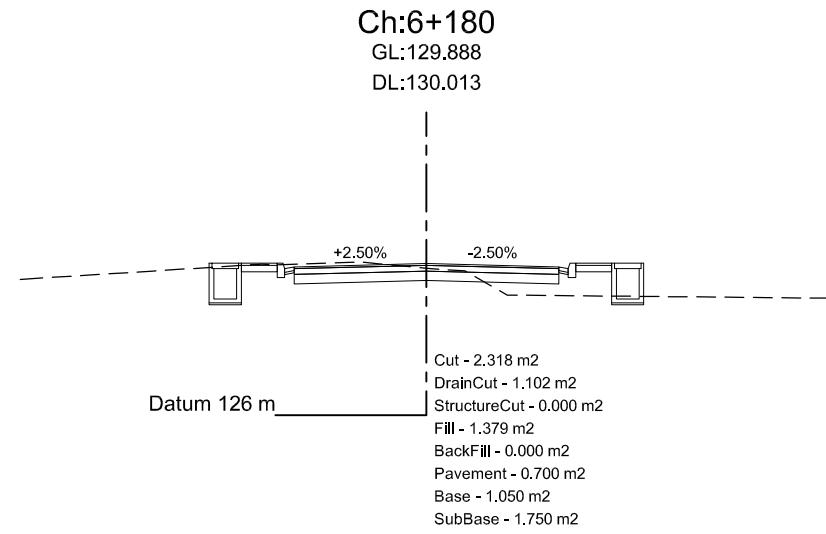
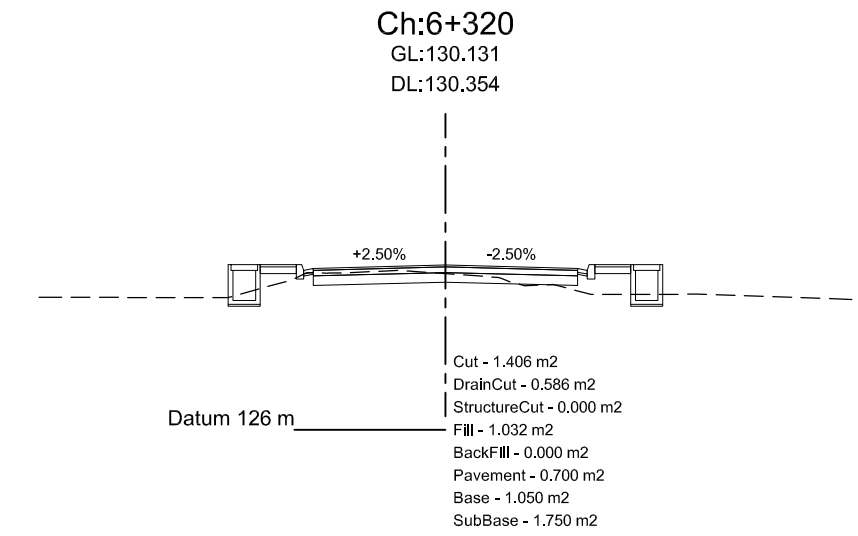
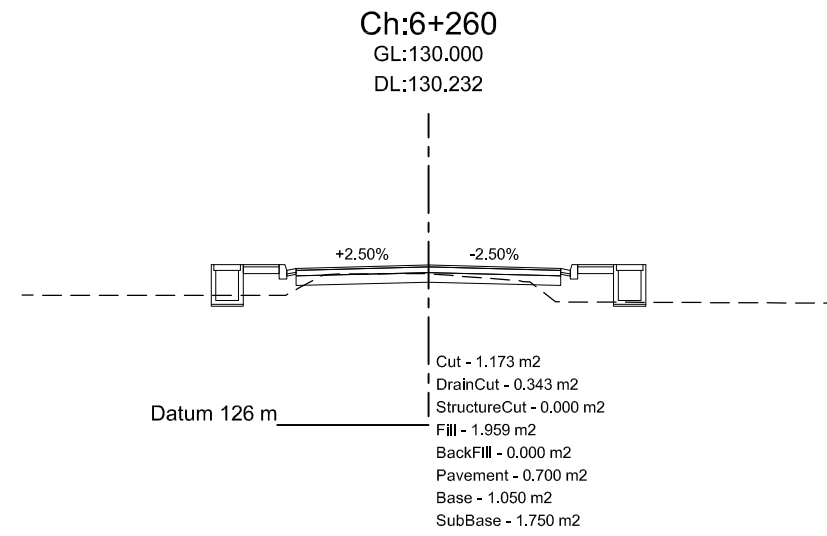
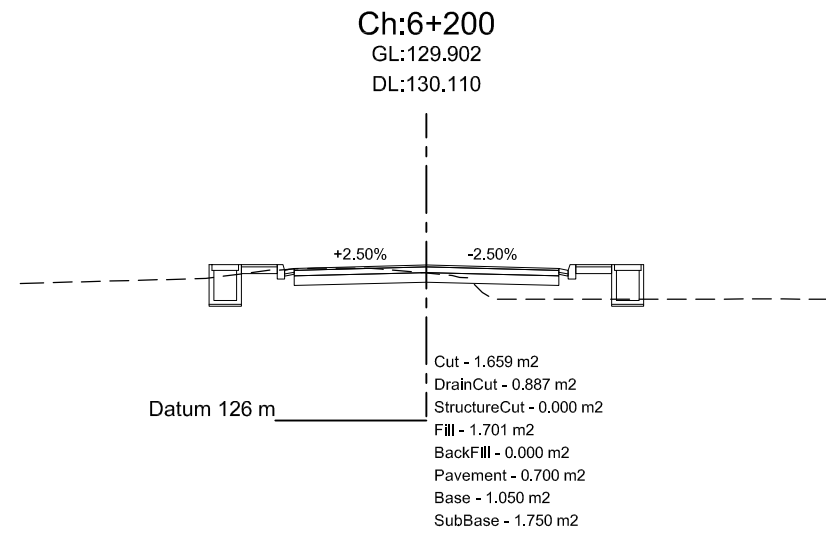

Department of Urban Development & Building
Construction (DUDBC)
Regional Urban Development Project (RUDP)
West Urban Corridor (WUC) Development Project
Babarmahal, Kathmandu, Nepal

Reviewed & Designed By :
DOHWA Engineering Co. Ltd.
in Association with
ERMIC (P.) Ltd., SILT Consultants (P.) Ltd., and
DIGICON (P.) Ltd.
Mid- Baneshwor, Kathmandu
Tel: 01- 4589393

Consultant
Team Leader : YOO CHANGMIN
Reviewed By : YAGYA BAHADUR MALLA
Designed By : MANJU MUNANKARMI

Client
Approved By :
Checked By :

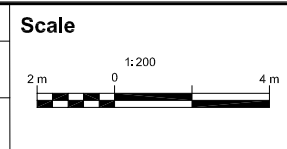

Cross-Section
BHALUHIPUL-MEDICAL COLLEGE-
BHATATOL-MUKHIYATOL-PIPARHIYA-
SINGHA-MUNICIPALITY
CH 0+000 - 7+503.82 Km

REV : MAY 2024
DRG NO : DM/RD/CS/38
CHAINAGE : 6+160-6+320
SHEET NO : 38

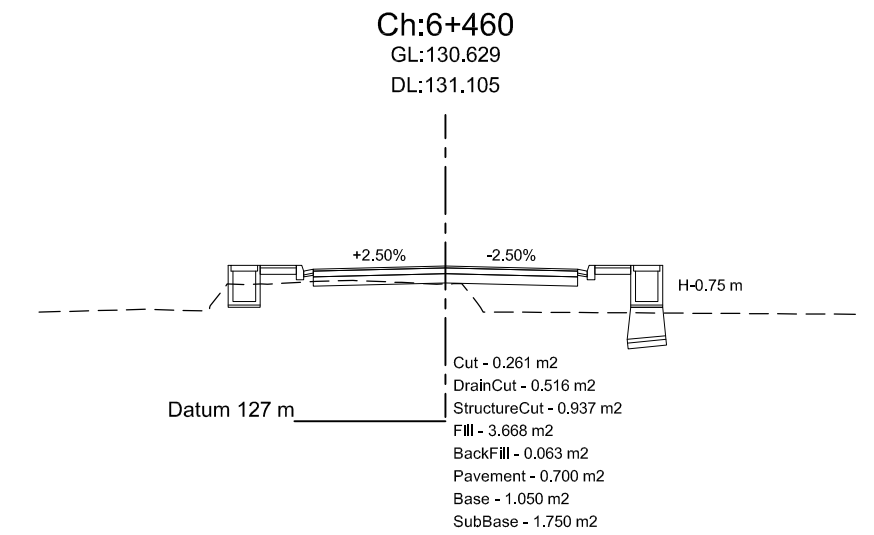
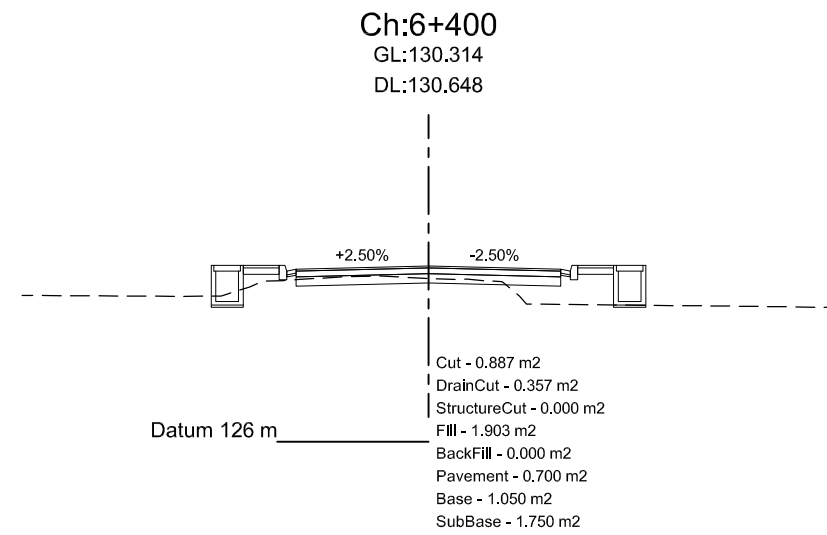
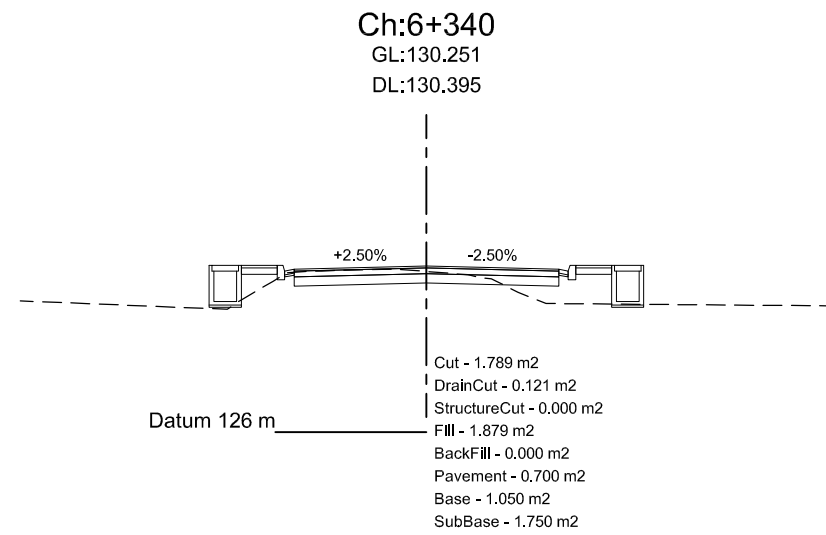
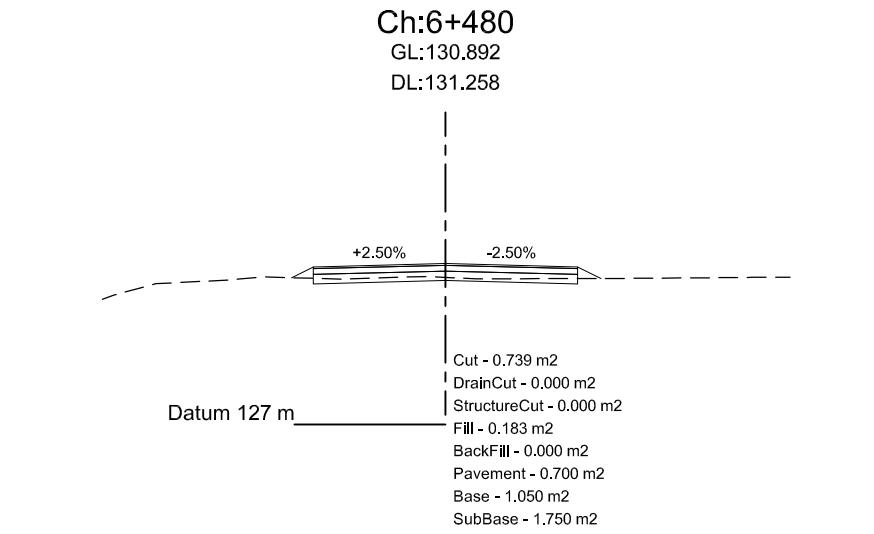
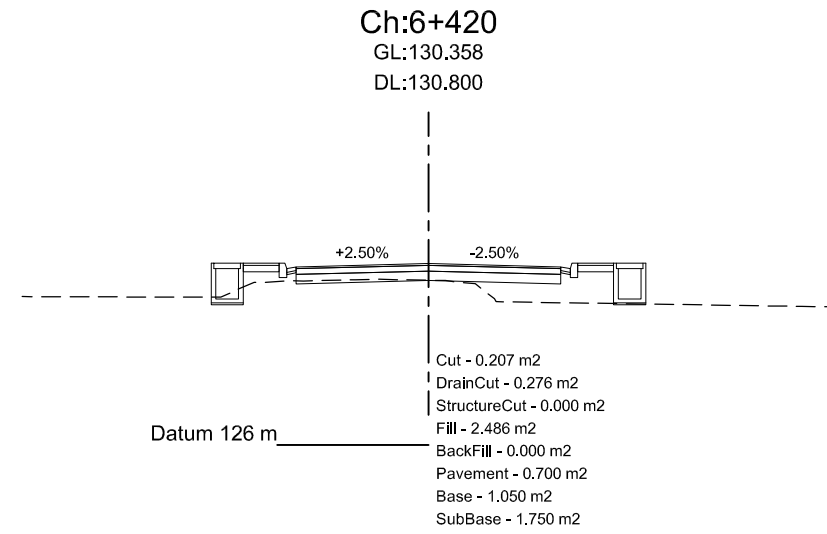
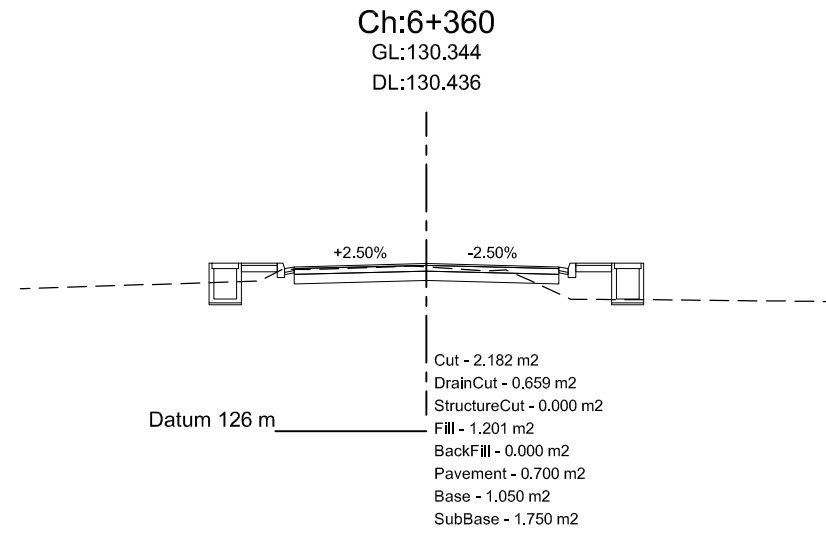
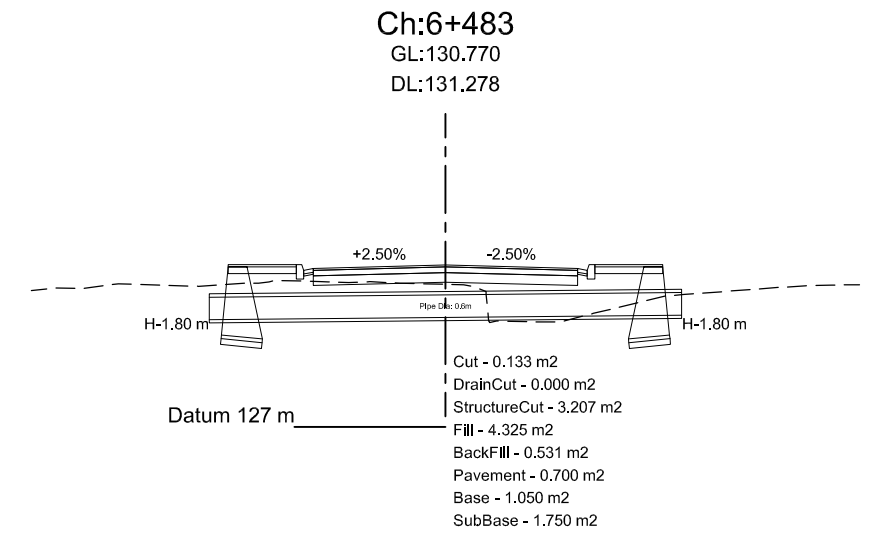
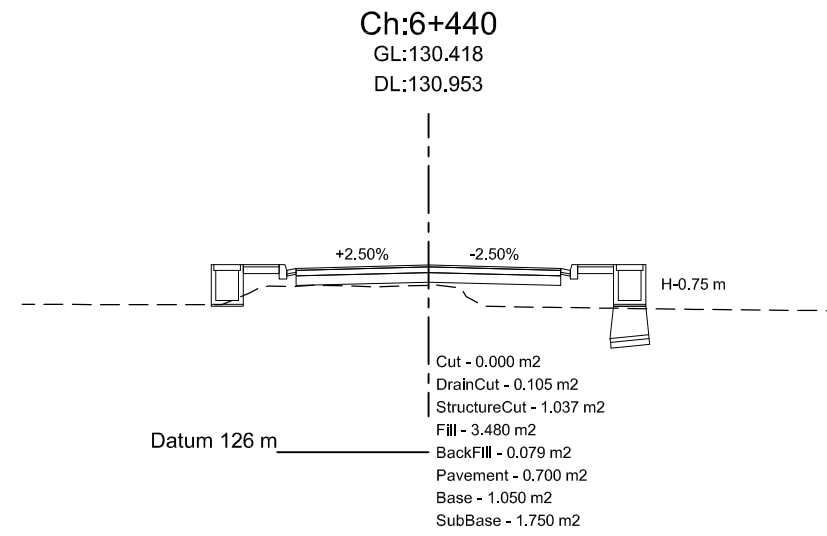
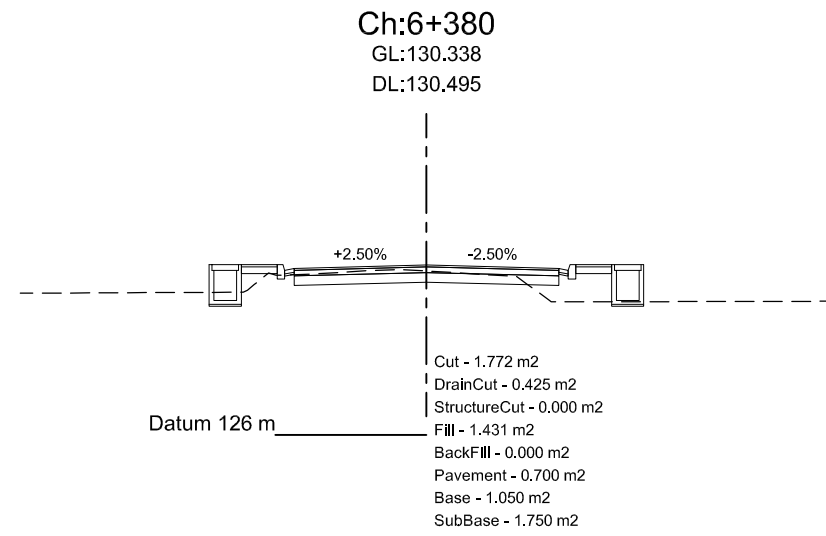

Department of Urban Development & Building Construction (DUDBC)
Regional Urban Development Project (RUDP)
West Urban Corridor (WUC) Development Project
Babarmahal, Kathmandu, Nepal

Reviewed & Designed By :
DOHWA Engineering Co. Ltd.
in Association with
ERMIC (P.) Ltd., SILT Consultants (P.) Ltd., and
DIGICON (P.) Ltd.
Mid- Baneshwor, Kathmandu
Tel: 01- 4589393

Consultant
Team Leader : YOO CHANGMIN
Reviewed By : YAGYA BAHADUR MALLA
Designed By : MANJU MUNANKARMI

Client
Approved By :
Checked By :

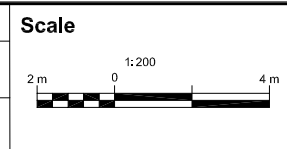

Cross-Section
BHALUHIPUL-MEDICAL COLLEGE-
BHATATOL-MUKHIYATOL-PIPARHIYA-
SINGHA-MUNICIPALITY
CH 0+000 - 7+503.82 Km

REV : MAY 2024
DRG NO : DM/RD/CS/39
CHAINAGE : 6+340-6+483
SHEET NO : 39

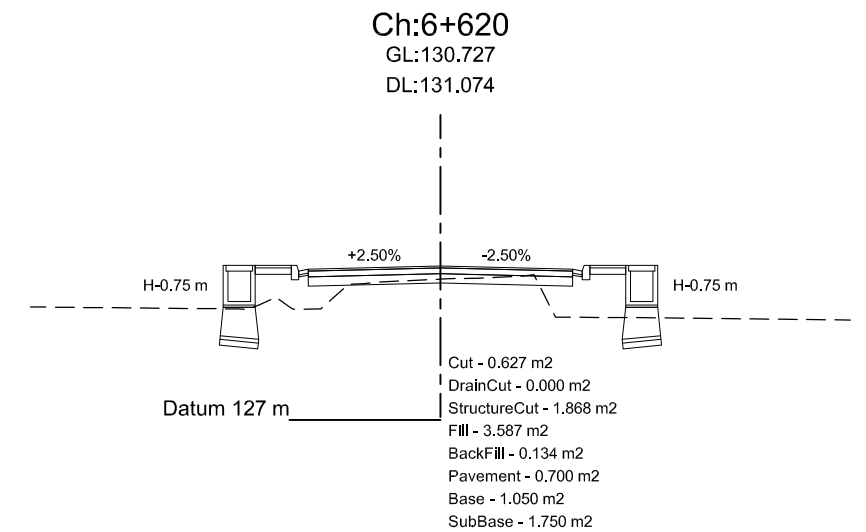
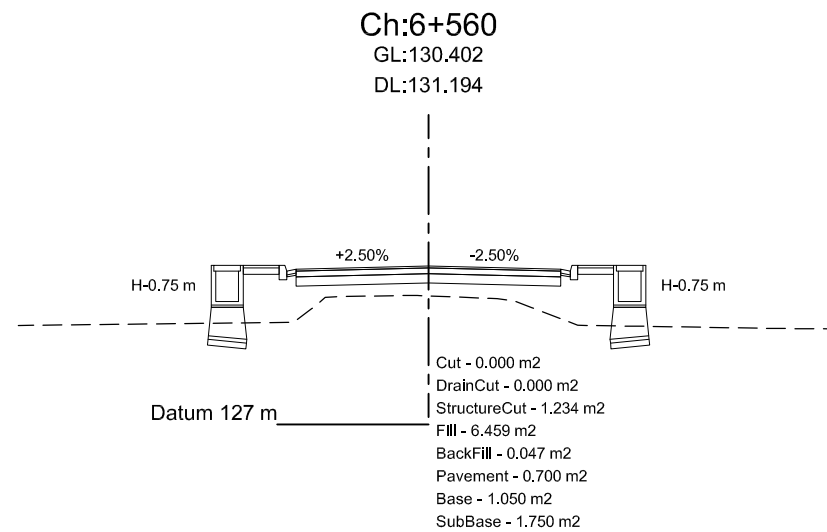
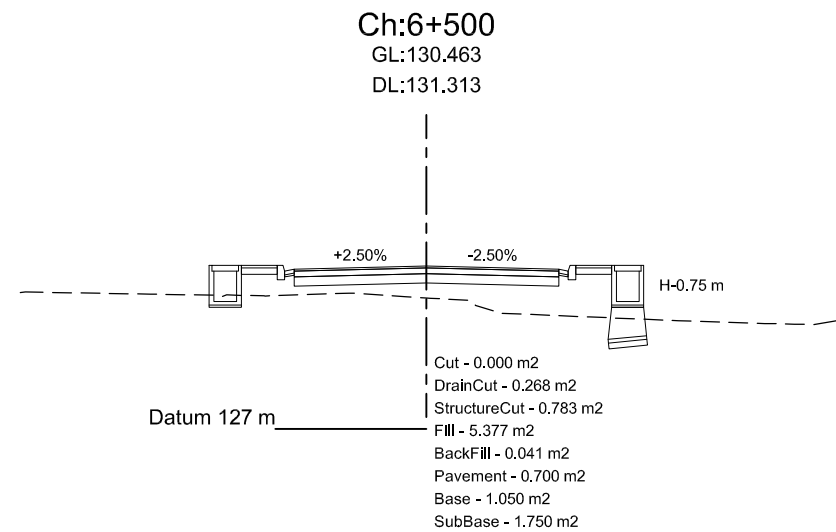
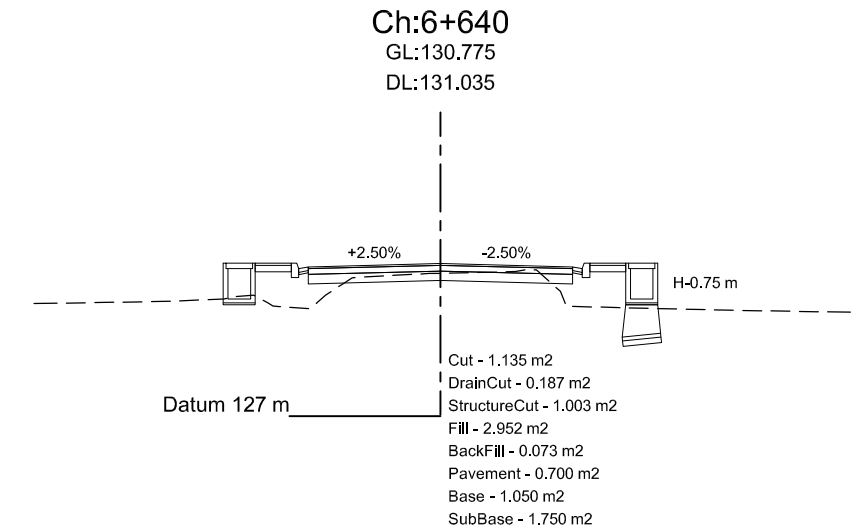
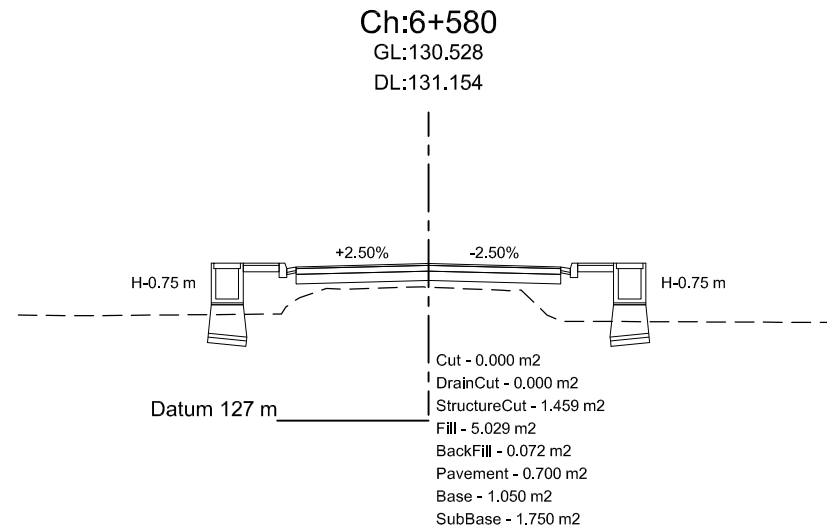
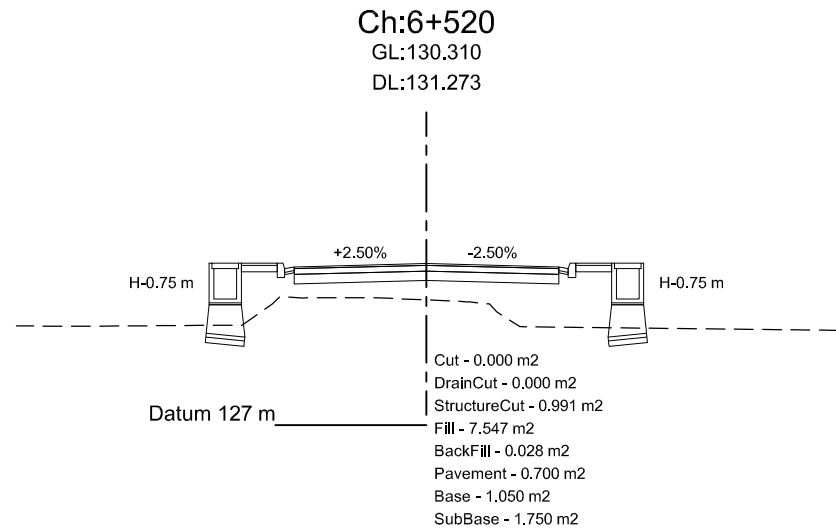
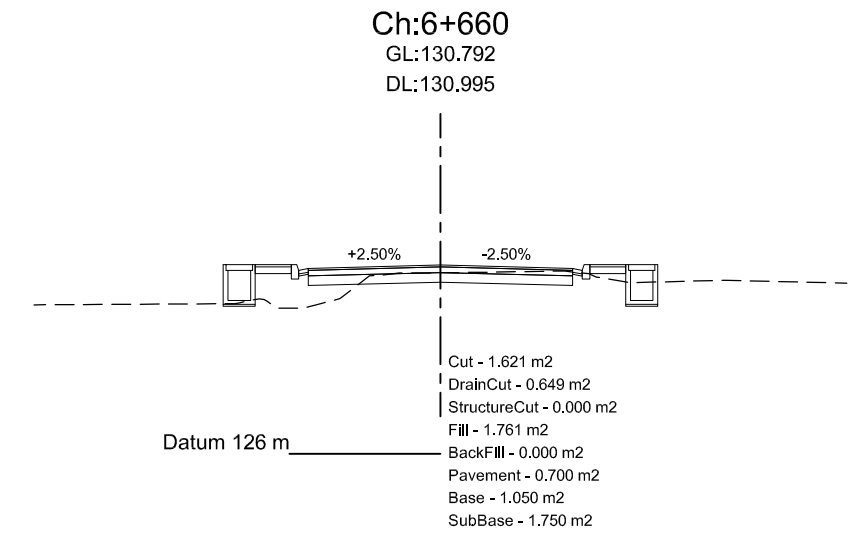
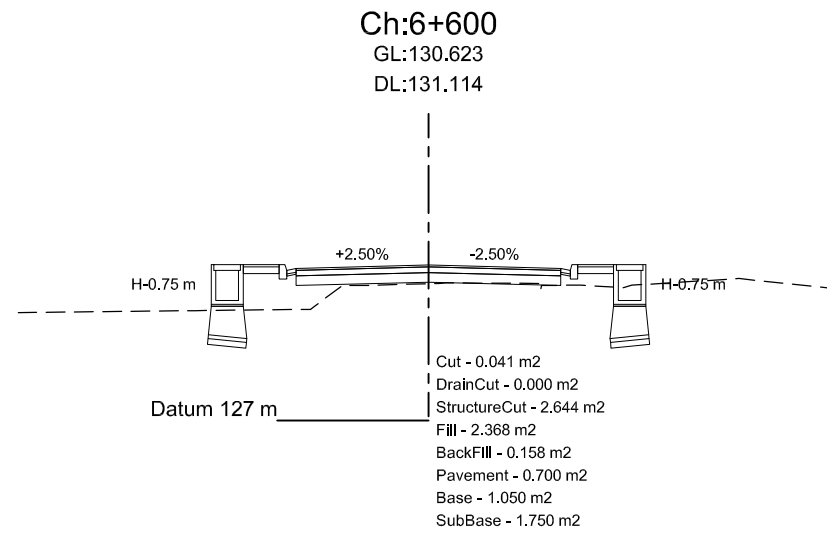
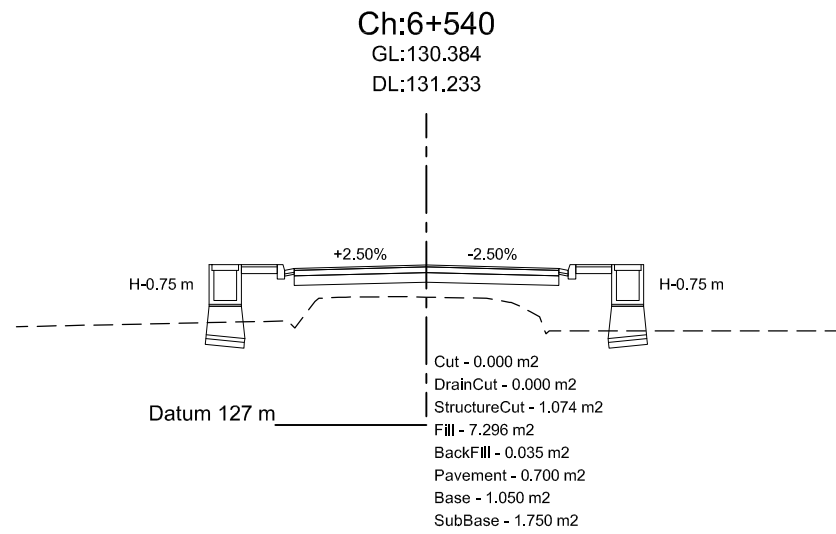

Department of Urban Development & Building
Construction (DUDBC)
Regional Urban Development Project (RUDP)
West Urban Corridor (WUC) Development Project
Babarmahal, Kathmandu, Nepal

Reviewed & Designed By :
DOHWA Engineering Co. Ltd.
in Association with
ERMIC (P.) Ltd., SILT Consultants (P.) Ltd., and
DIGICON (P.) Ltd.
Mid-Baneshwor, Kathmandu
Tel: 01-4589393

Consultant
Team Leader : YOO CHANGMIN
Reviewed By : YAGYA BAHADUR MALLA
Designed By : MANJU MUNANKARMI

Client
Approved By :
Checked By :

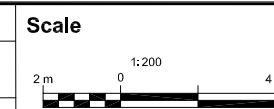

Cross-Section
BHALUHIPUL-MEDICAL COLLEGE-
BHATATOL-MUKHIYATOL-PIPARHIYA-
SINGHA-MUNICIPALITY
CH 0+000 - 7+503.82 Km

REV : MAY 2024
DRG NO : DM/RD/CS/40
CHAINAGE : 6+500-6+660
SHEET NO : 40

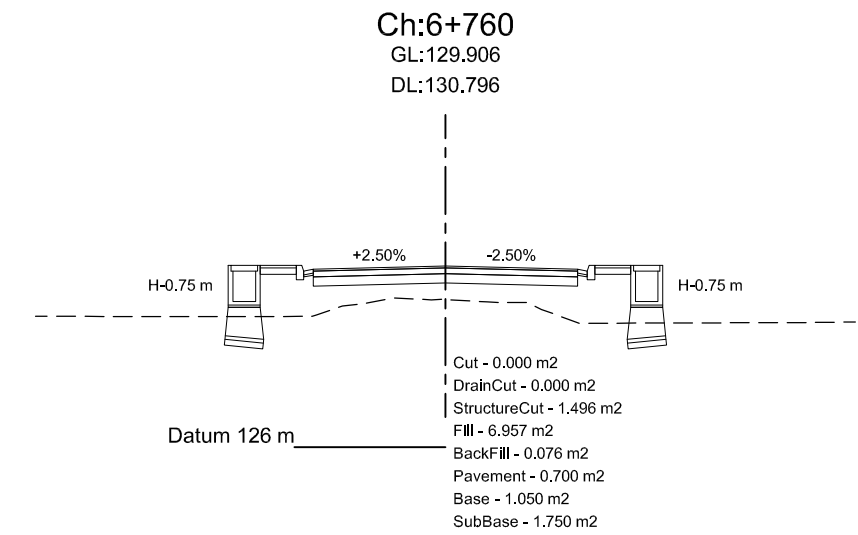
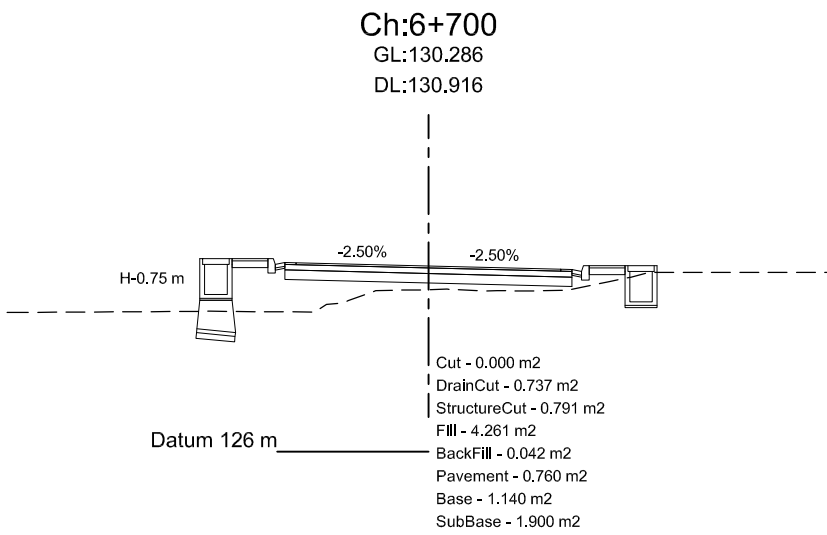
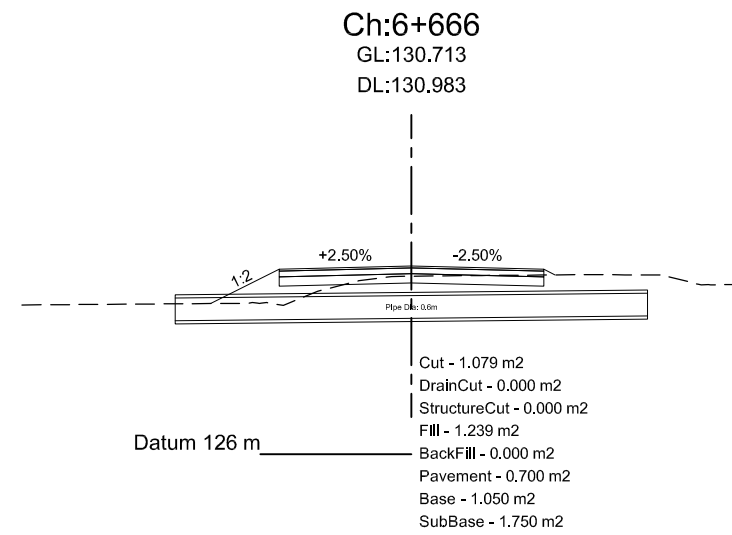
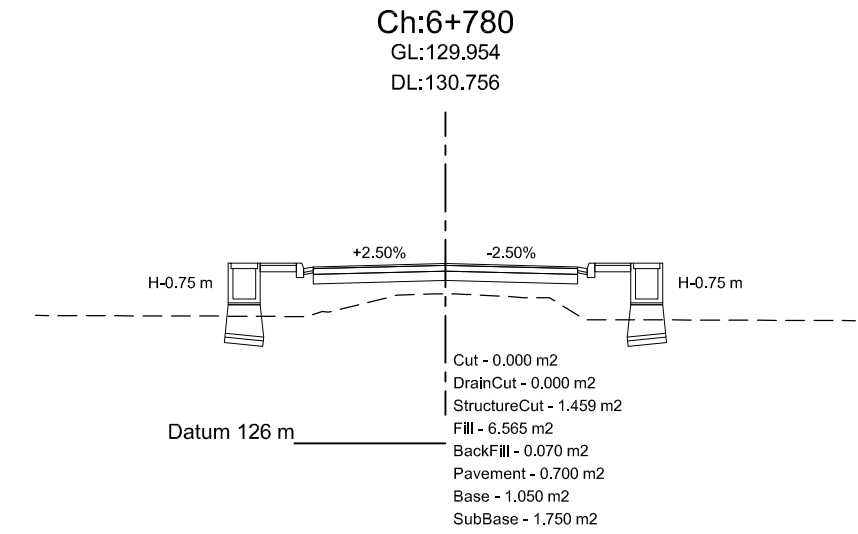
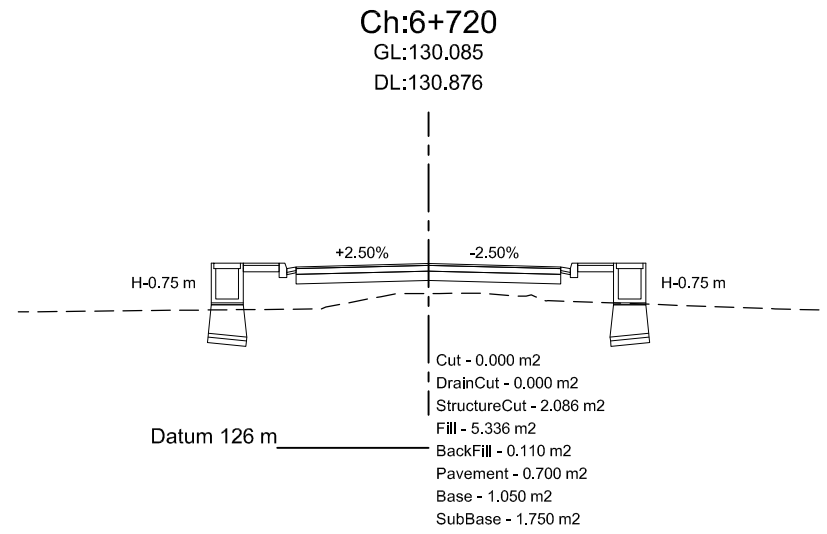
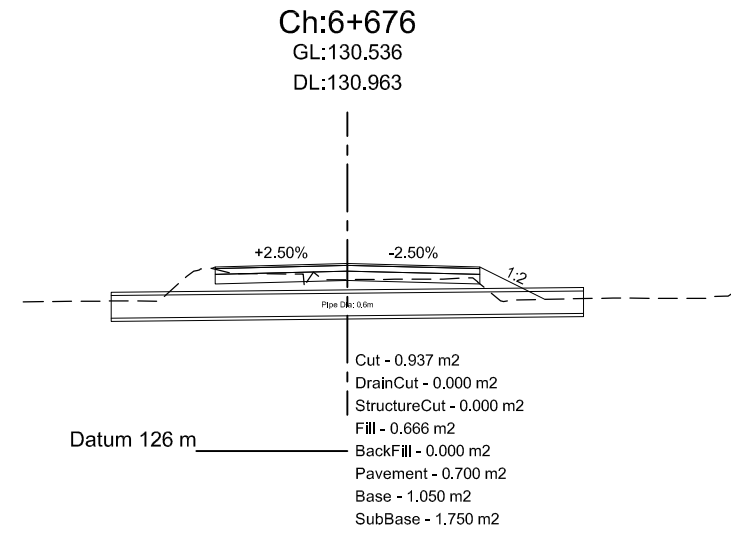
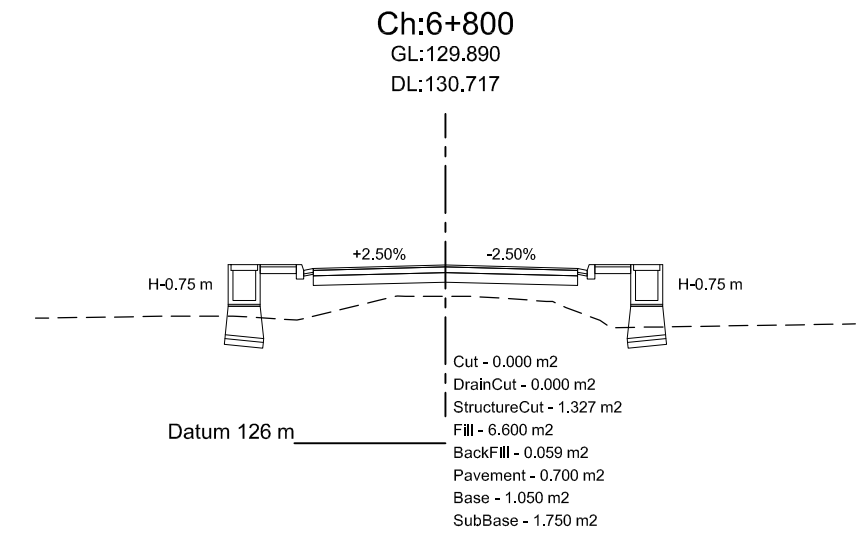
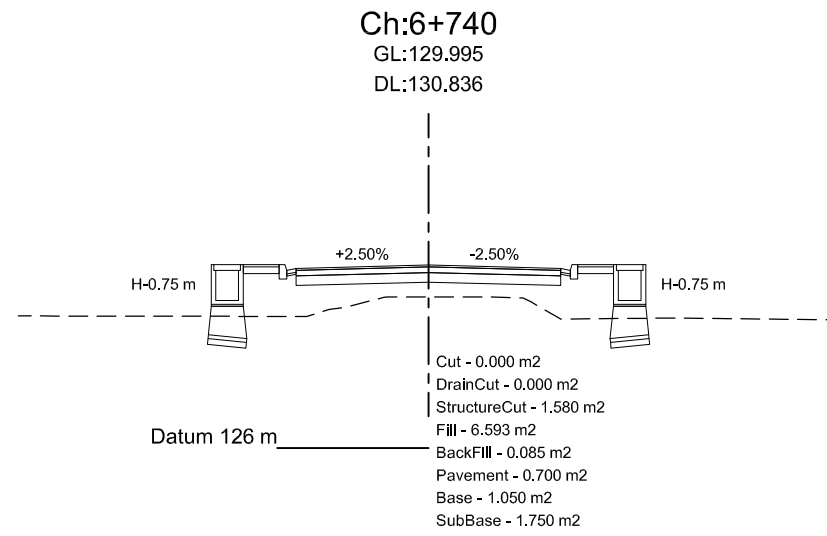
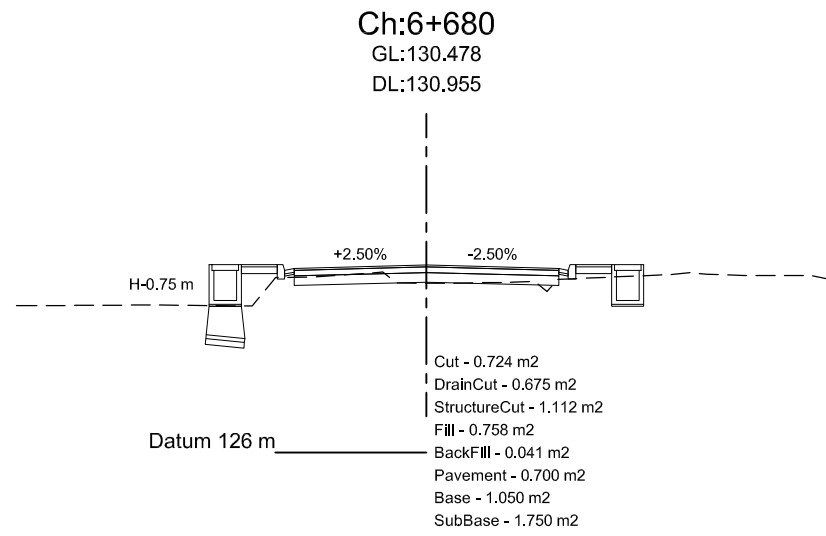

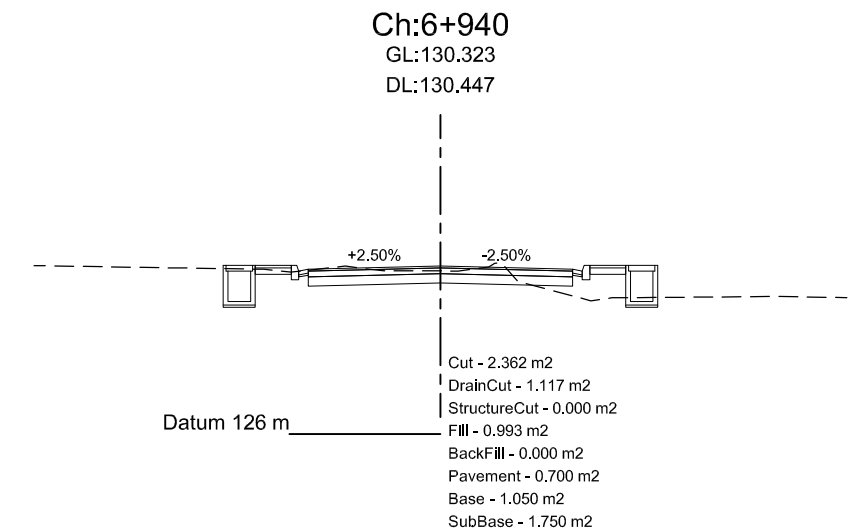
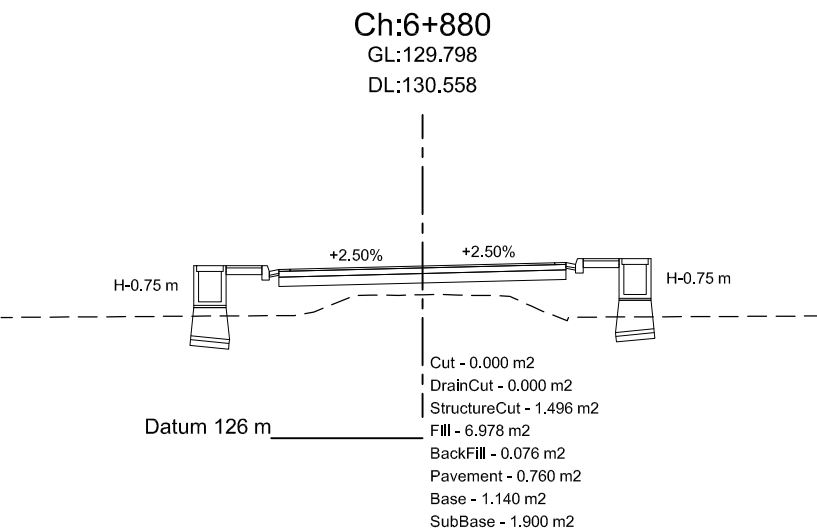
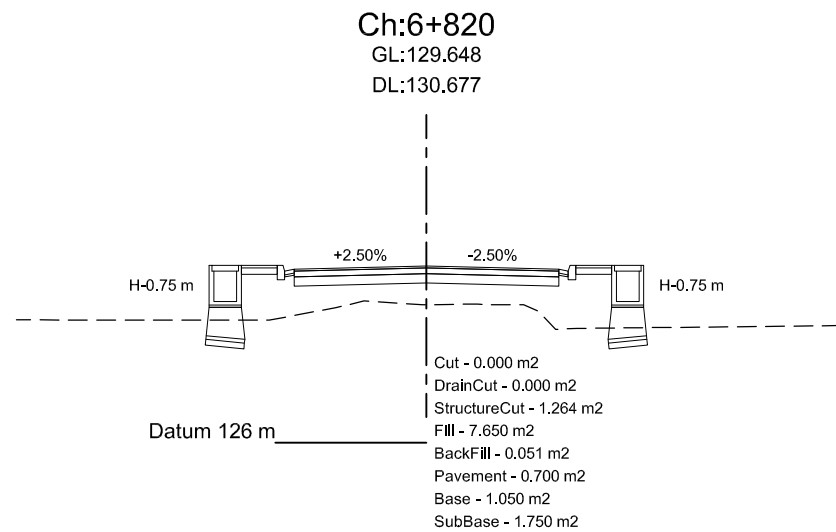
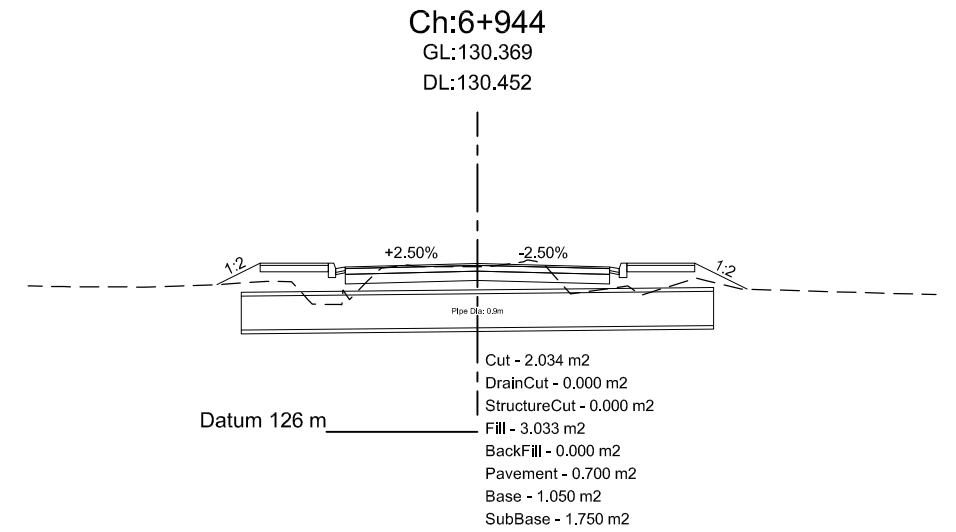
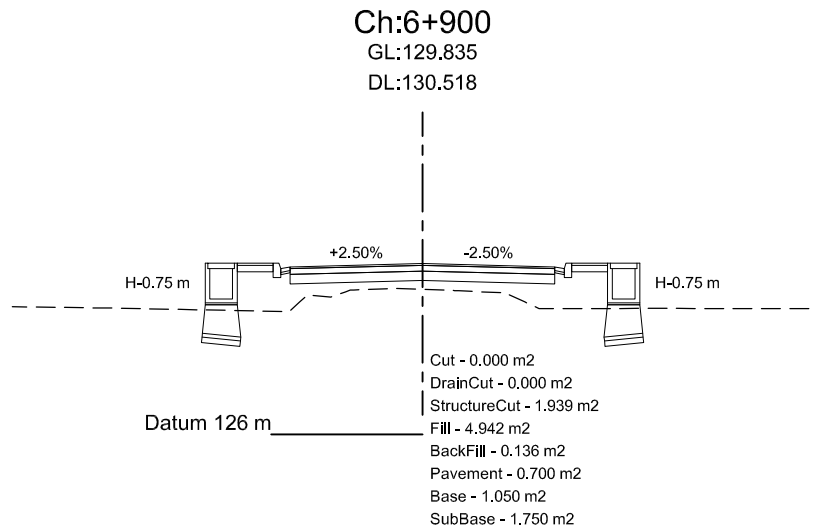
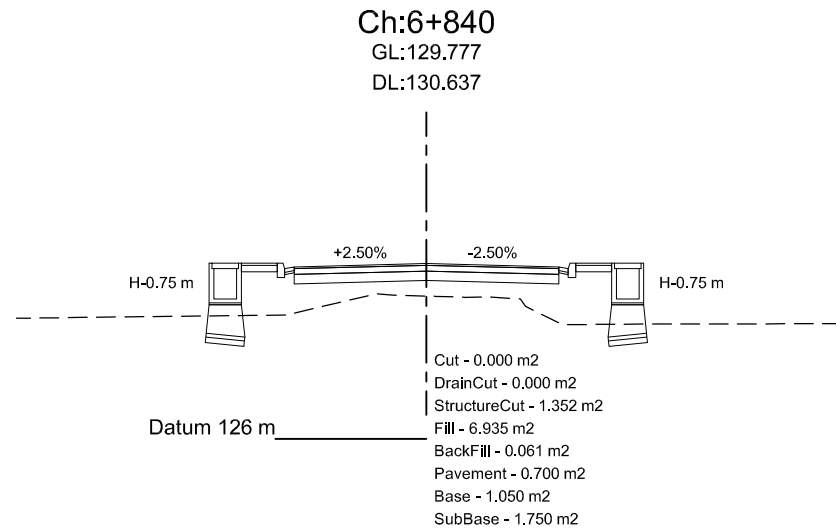
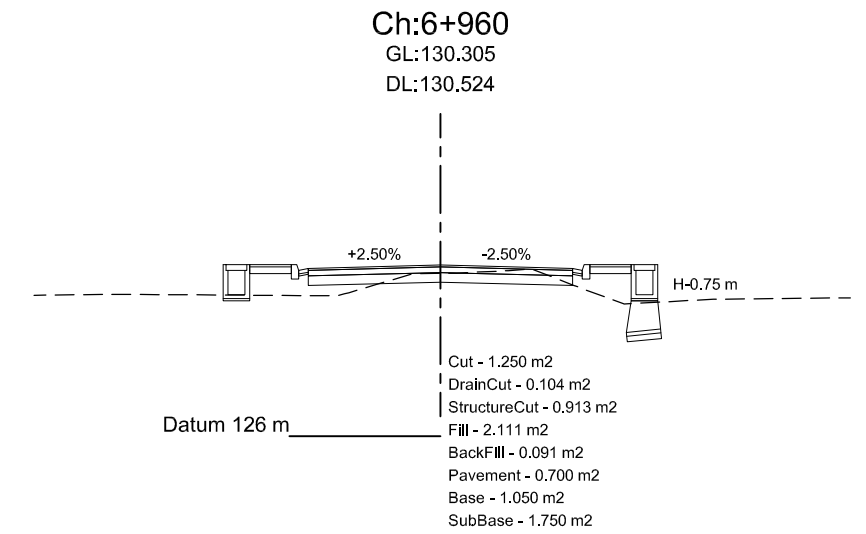
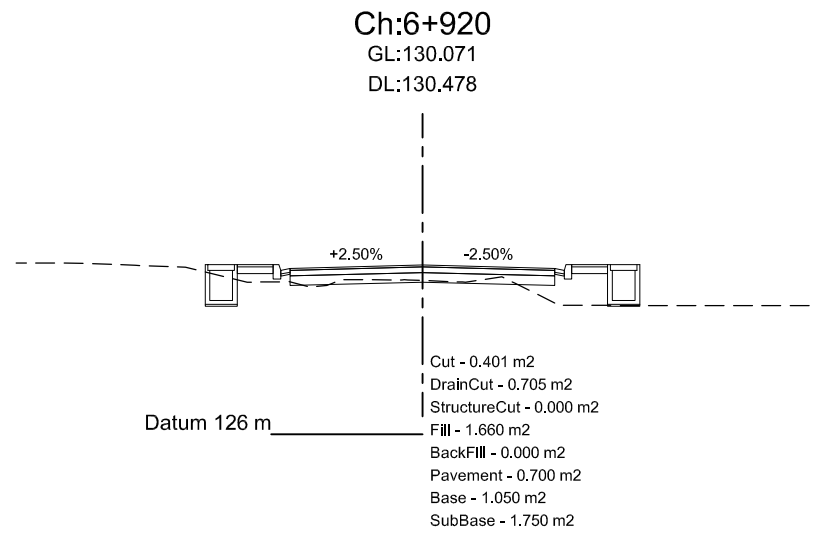
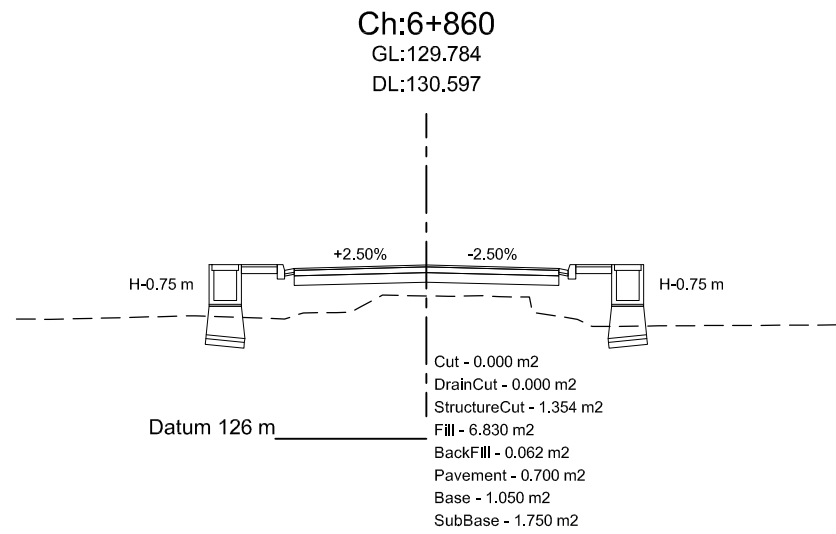

Department of Urban Development & Building
Construction (DUDBC)
Regional Urban Development Project (RUDP)
West Urban Corridor (WUC) Development Project
Babarmahal, Kathmandu, Nepal

Reviewed & Designed By :
DOHWA Engineering Co. Ltd.
in Association with
ERMIC (P.) Ltd., SILT Consultants (P.) Ltd., and
DIGICON (P.) Ltd.
Mid- Baneshwor, Kathmandu
Tel: 01- 4589393

Consultant
Team Leader : YOO CHANGMIN
Reviewed By : YAGYA BAHADUR MALLA
Designed By : MANJU MUNANKARMI

Client
Approved By :
Checked By :

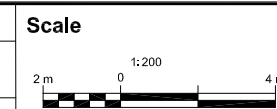

Cross-Section
BHALUHIPUL-MEDICAL COLLEGE-
BHATATOL-MUKHIYATOL-PIPARHIYA-
SINGHA-MUNICIPALITY
CH 0+000 - 7+503.82 Km

REV : MAY 2024
DRG NO : DM/RD/CS/42
CHAINAGE : 6+820-6+960
SHEET NO : 42

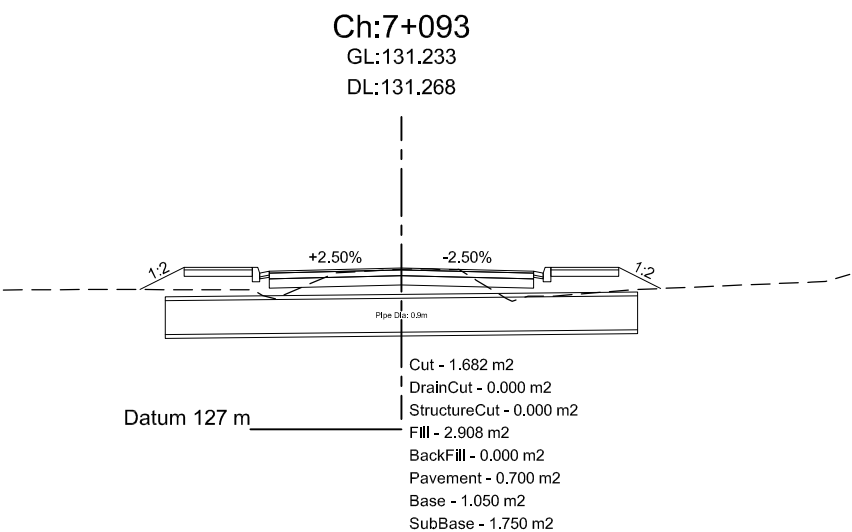
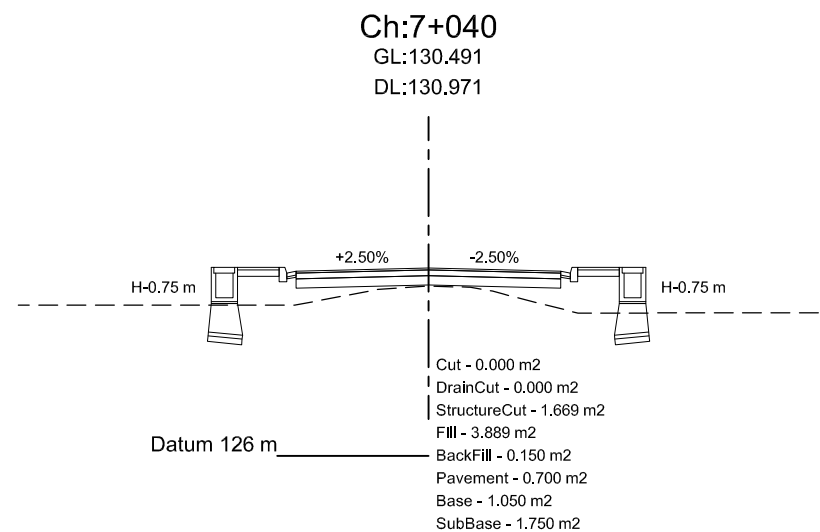
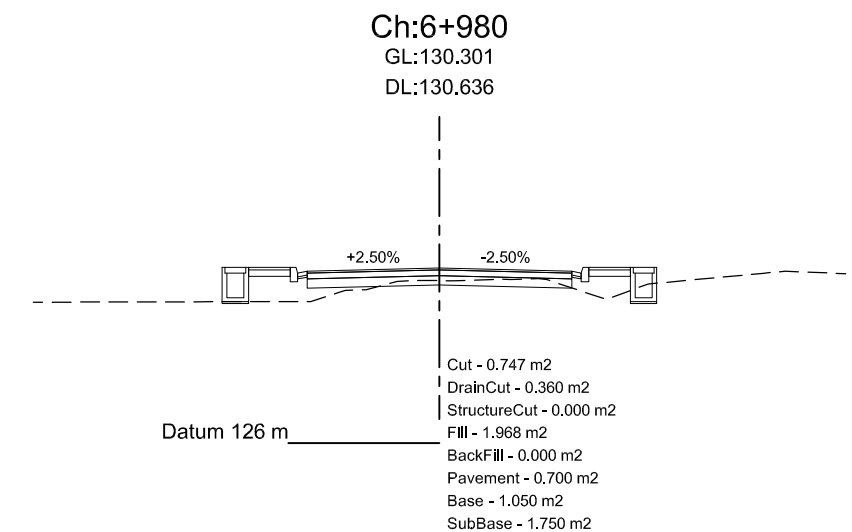
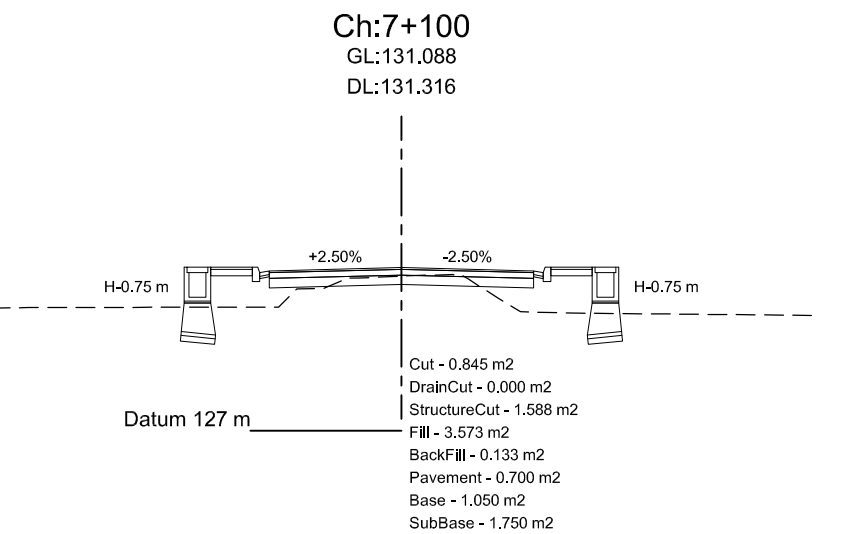
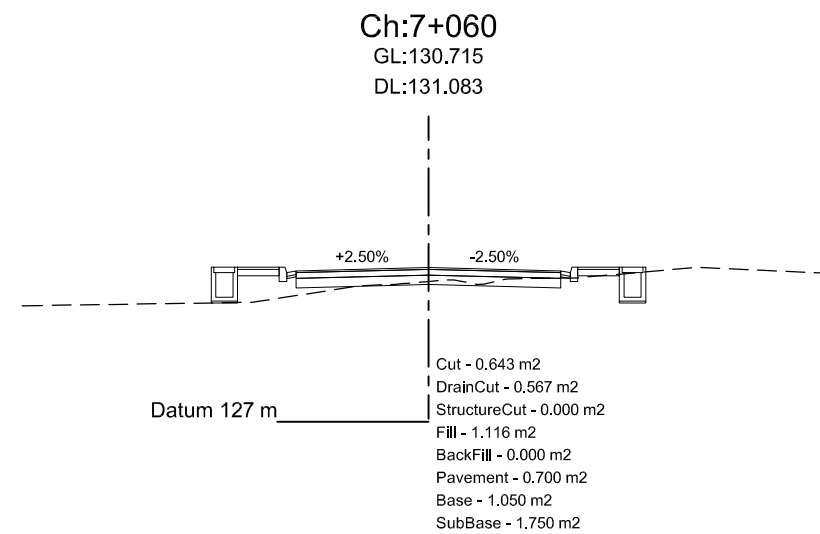
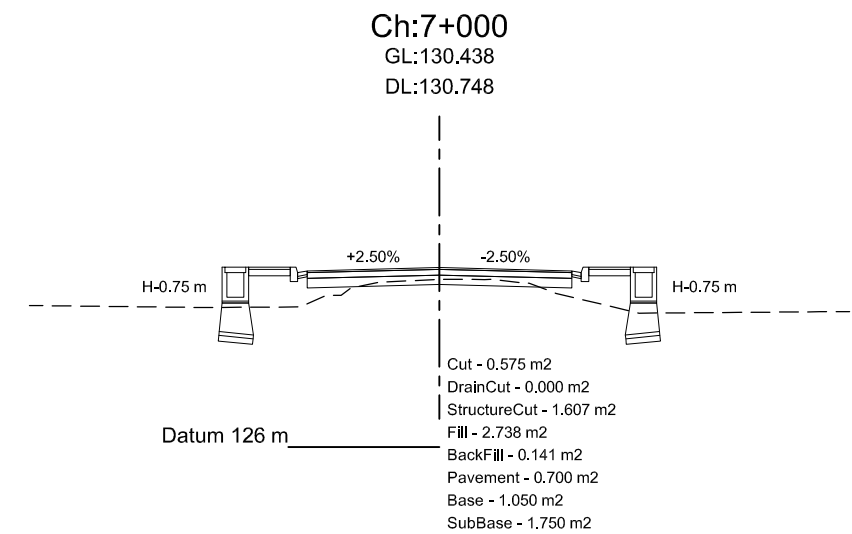
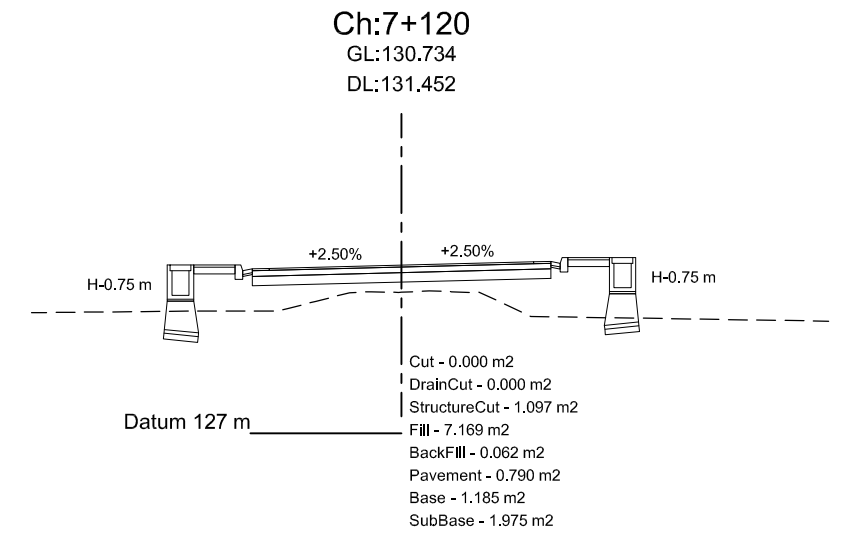
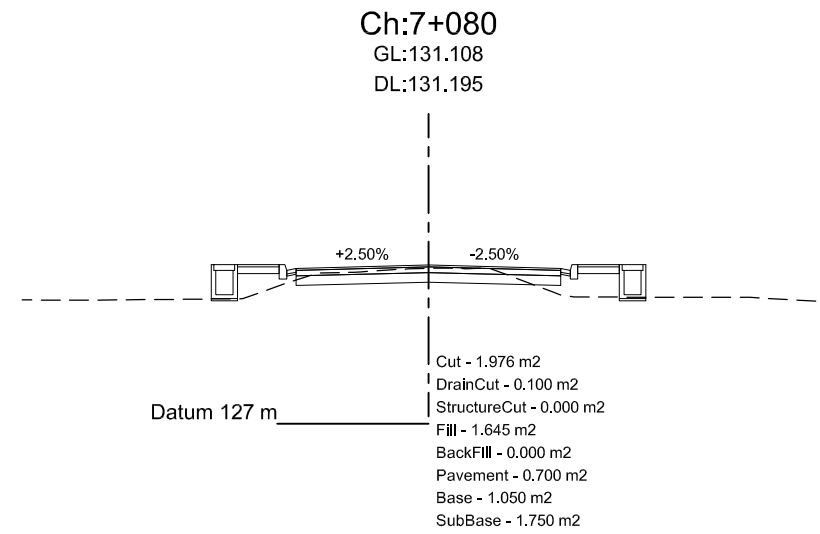
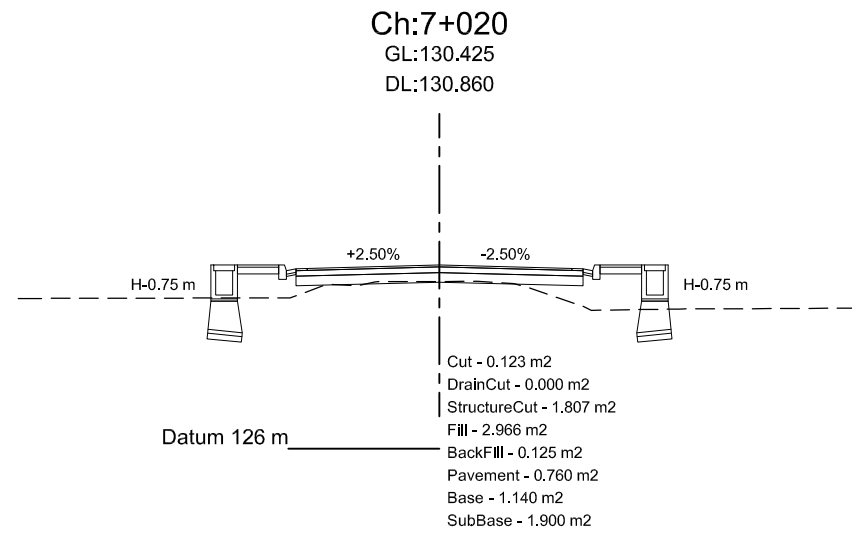

Department of Urban Development & Building
Construction (DUDBC)
Regional Urban Development Project (RUDP)
West Urban Corridor (WUC) Development Project
Babarmahal, Kathmandu, Nepal

Reviewed & Designed By :
DOHWA Engineering Co. Ltd.
in Association with
ERMIC (P.) Ltd., SILT Consultants (P.) Ltd., and
DIGICON (P.) Ltd.
Mid- Baneshwor, Kathmandu
Tel: 01- 4589393

Consultant
Team Leader : YOO CHANGMIN
Reviewed By : YAGYA BAHADUR MALLA
Designed By : MANJU MUNANKARMI

Client
Approved By :
Checked By :

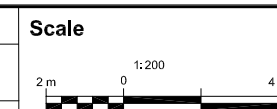

Cross-Section
BHALUHIPUL-MEDICAL COLLEGE-
BHATATOL-MUKHIYATOL-PIPARHIYA-
SINGHA-MUNICIPALITY
CH 0+000 - 7+503.82 Km

REV : MAY 2024
DRG NO : DM/RD/CS/43
CHAINAGE : 6+980-7+120
SHEET NO : 43

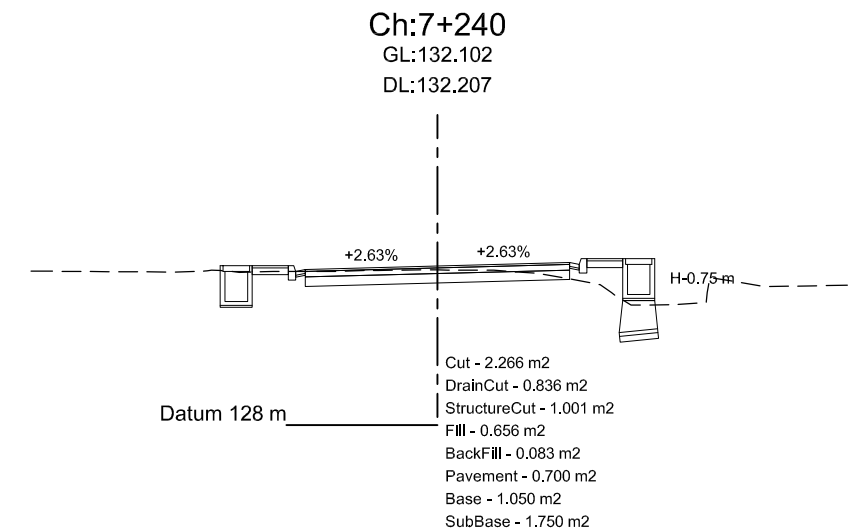
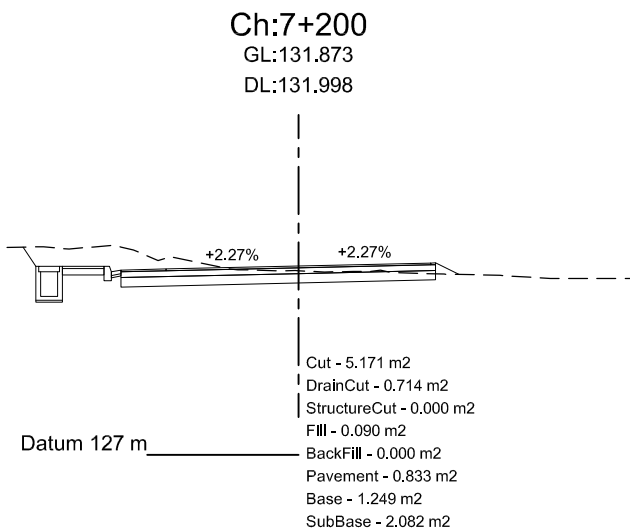
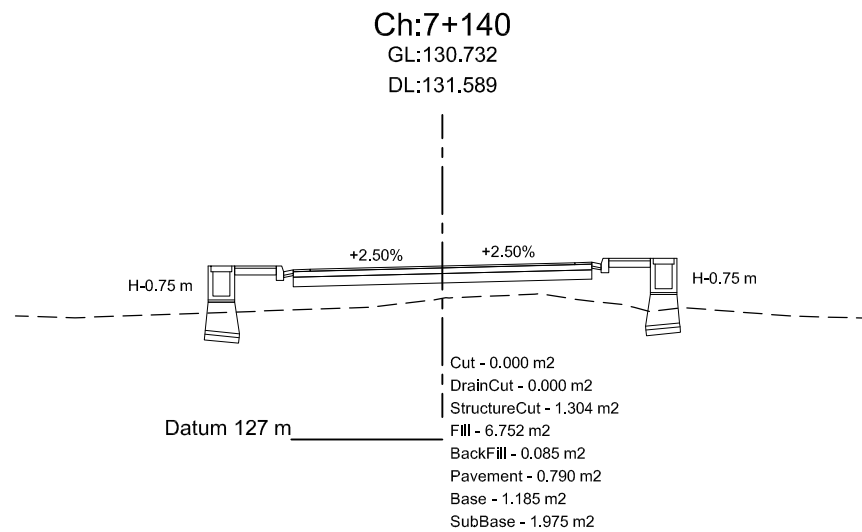
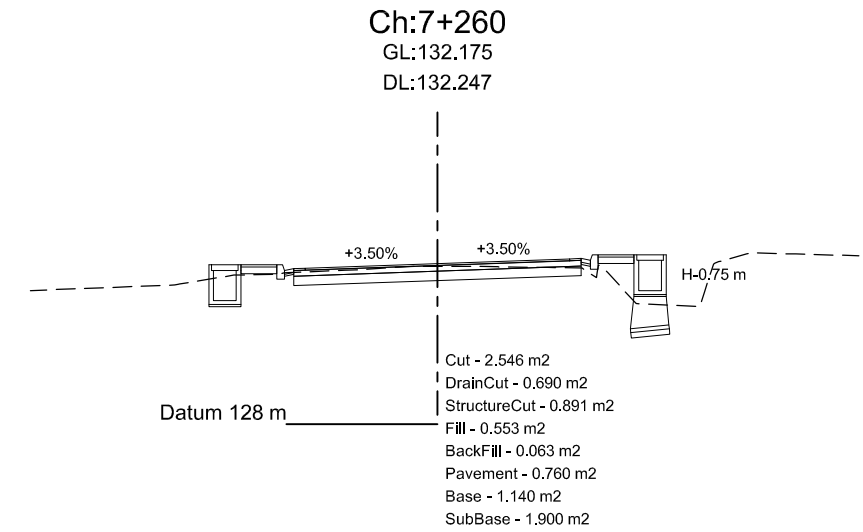
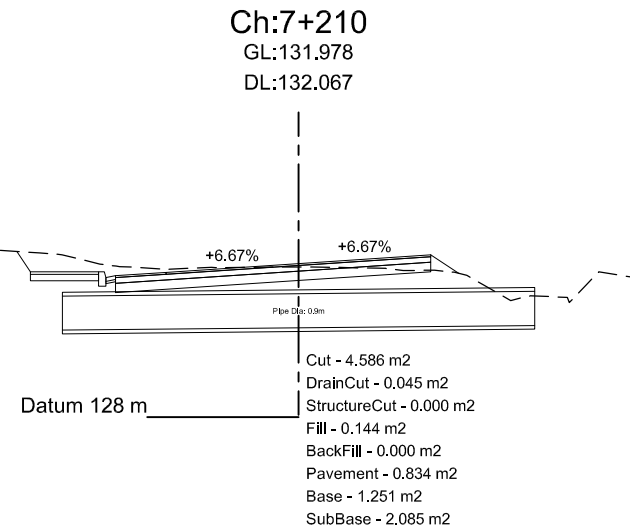
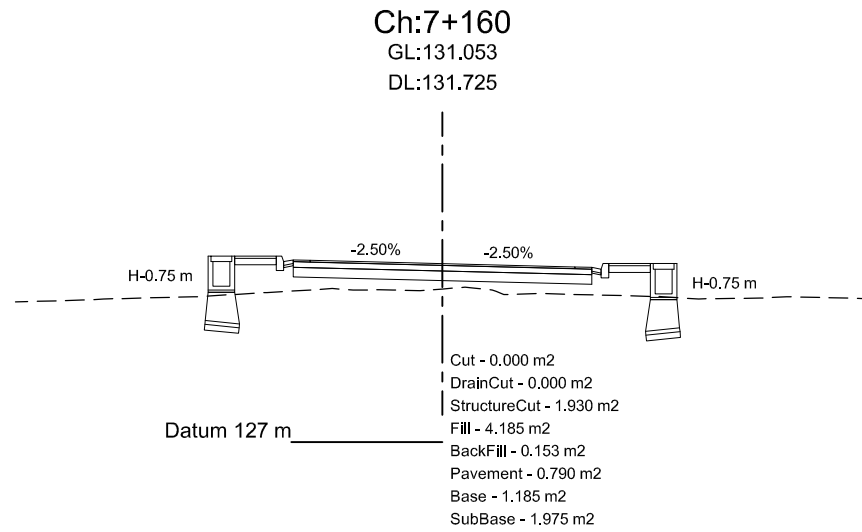
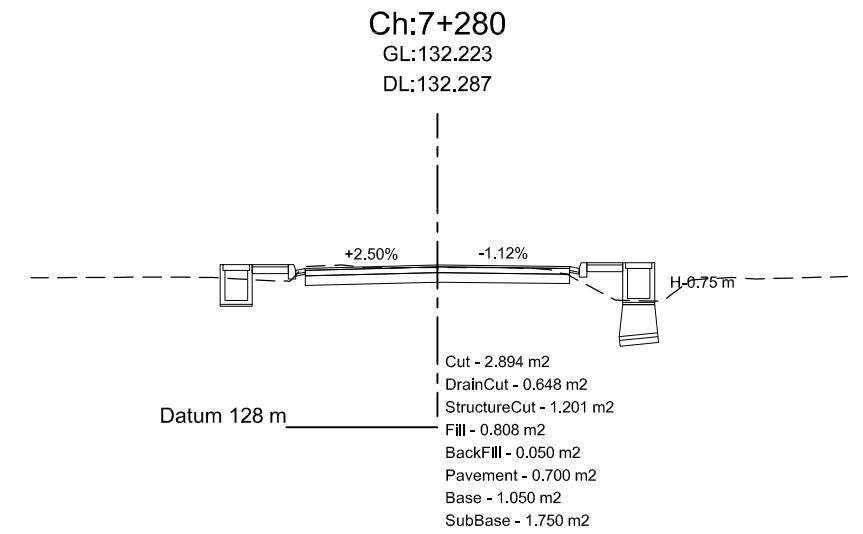
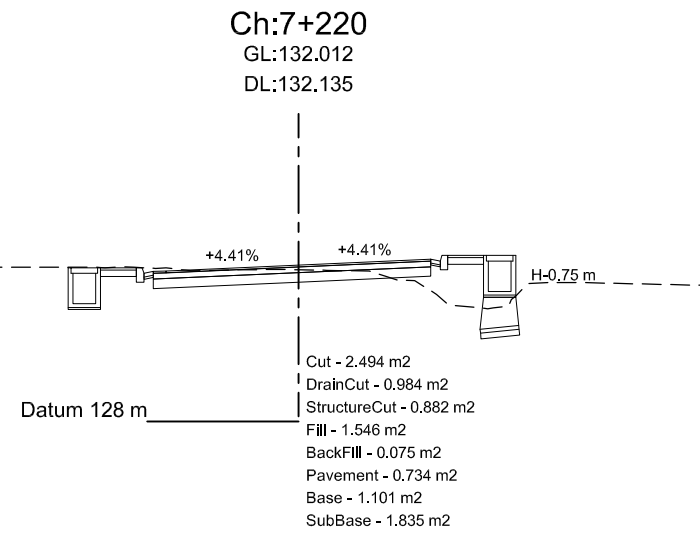
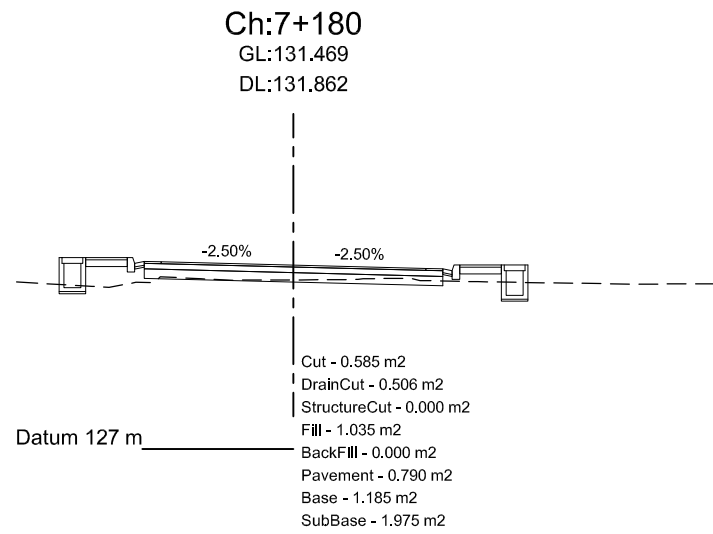

Department of Urban Development & Building
Construction (DUDBC)
Regional Urban Development Project (RUDP)
West Urban Corridor (WUC) Development Project
Babarmahal, Kathmandu, Nepal

Reviewed & Designed By :
DOHWA Engineering Co. Ltd.
in Association with
ERMIC (P.) Ltd., SILT Consultants (P.) Ltd., and
DIGICON (P.) Ltd.
Mid- Baneshwor, Kathmandu
Tel: 01- 4589393

Consultant
Team Leader : YOO CHANGMIN
Reviewed By : YAGYA BAHADUR MALLA
Designed By : MANJU MUNANKARMI

Client
Approved By :
Checked By :

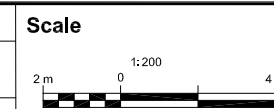

Cross-Section
BHALUHIPUL-MEDICAL COLLEGE-
BHATATOL-MUKHIYATOL-PIPARHIYA-
SINGHA-MUNICIPALITY
CH 0+000 - 7+503.82 Km

REV : MAY 2024
DRG NO : DM/RD/CS/44
CHAINAGE : 7+140-7+280
SHEET NO : 44

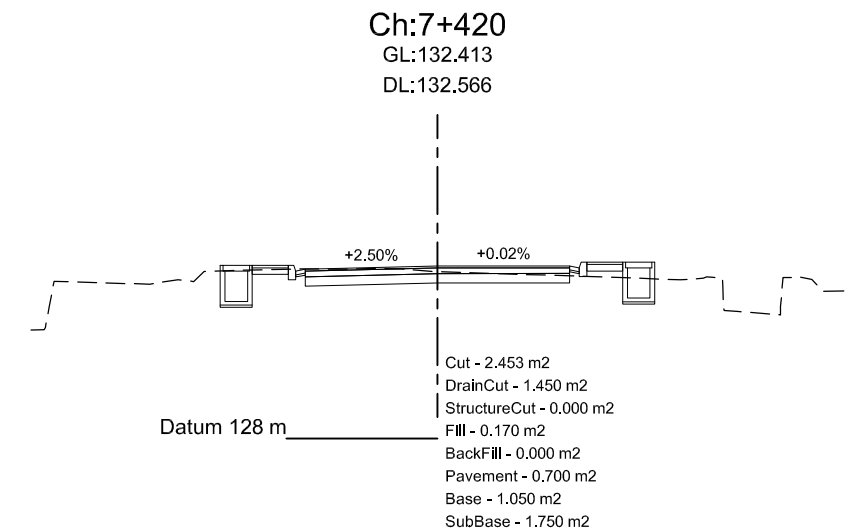
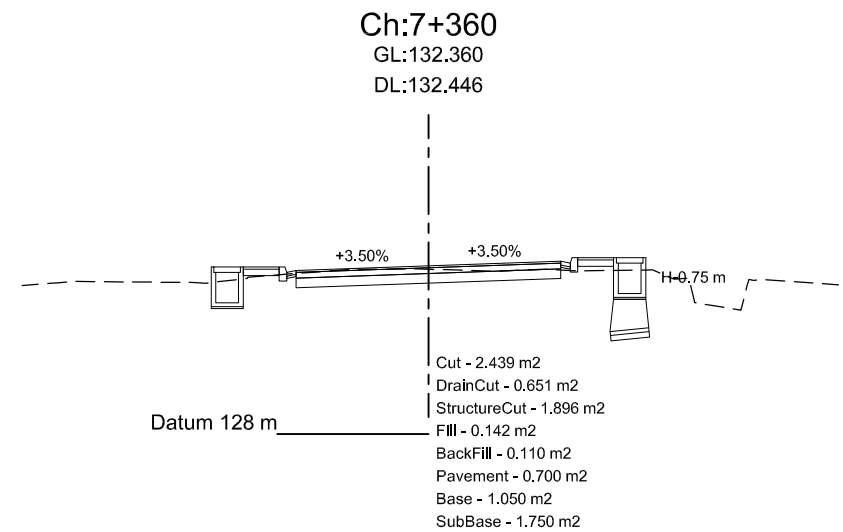
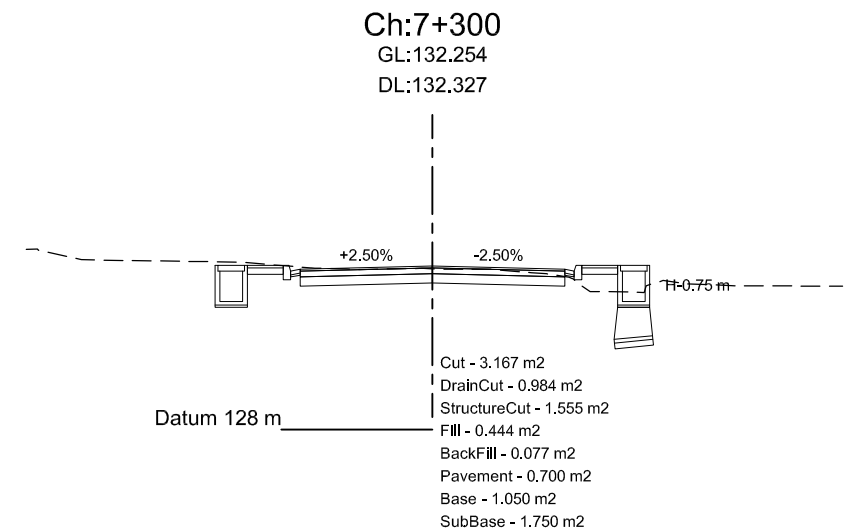
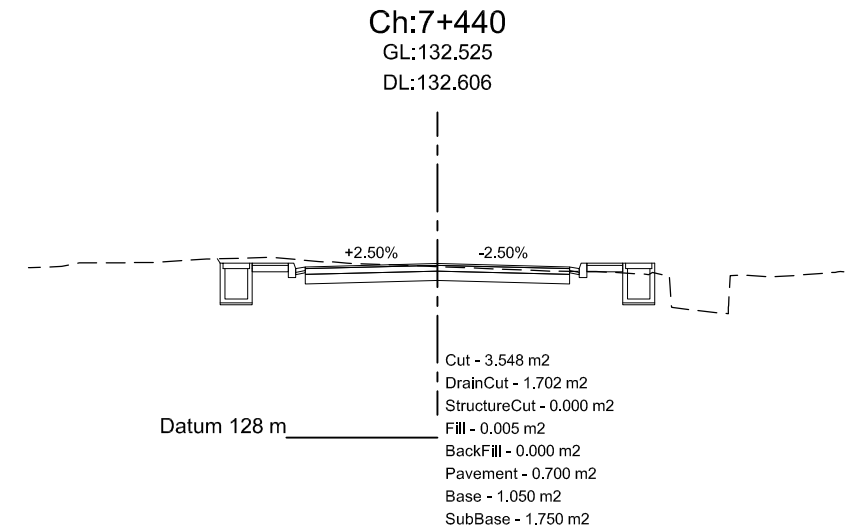
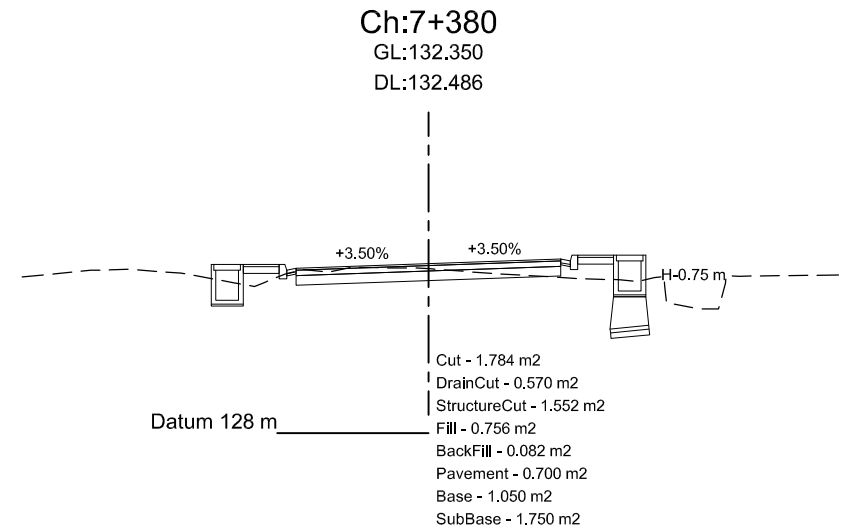
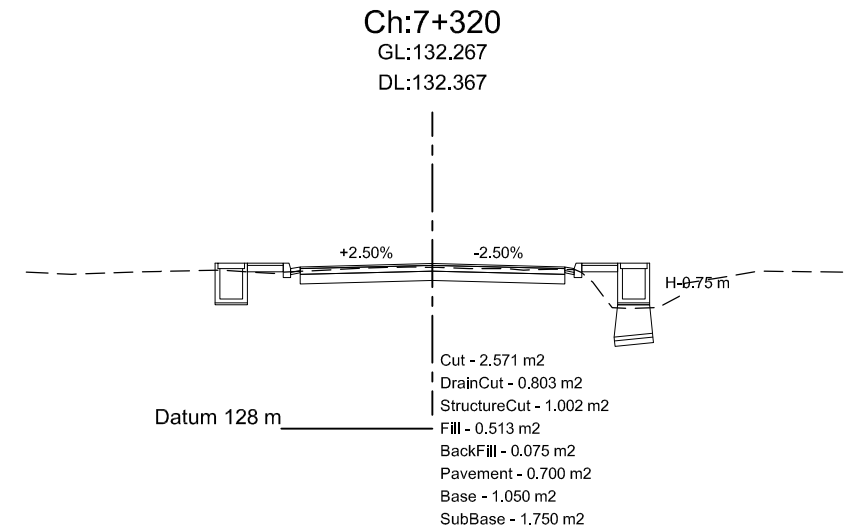
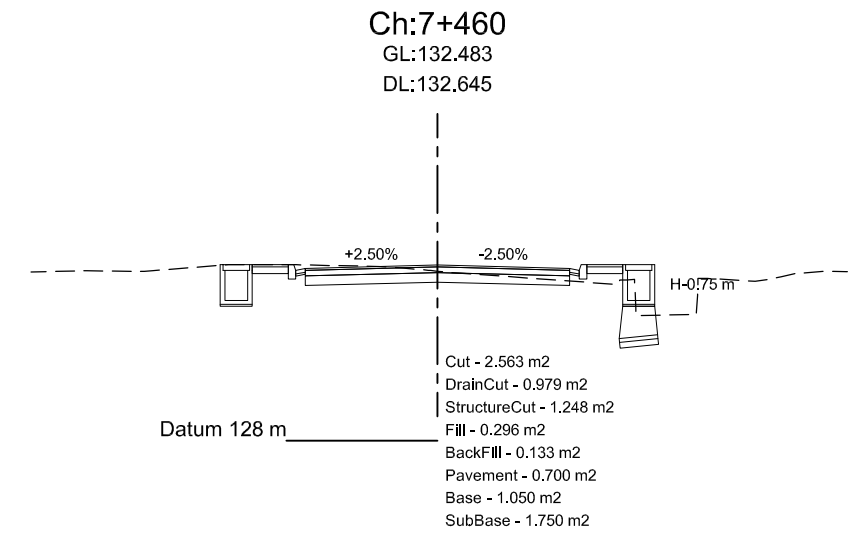
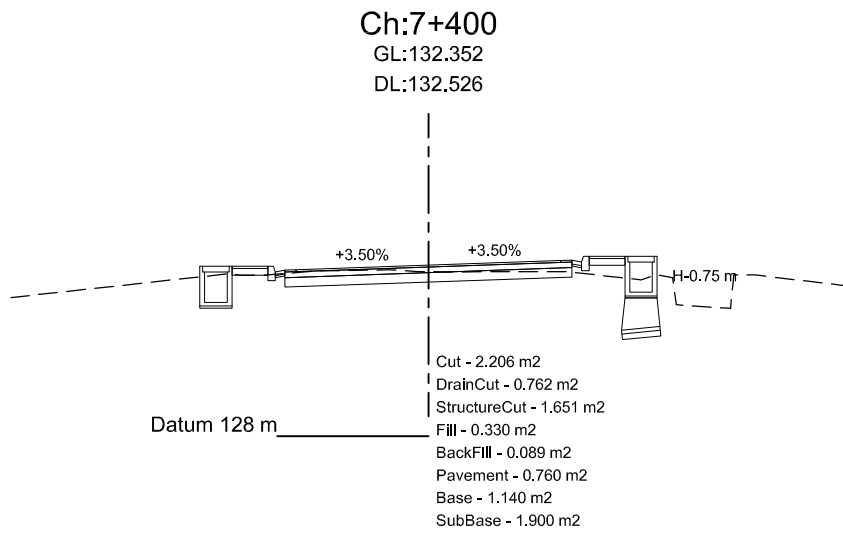
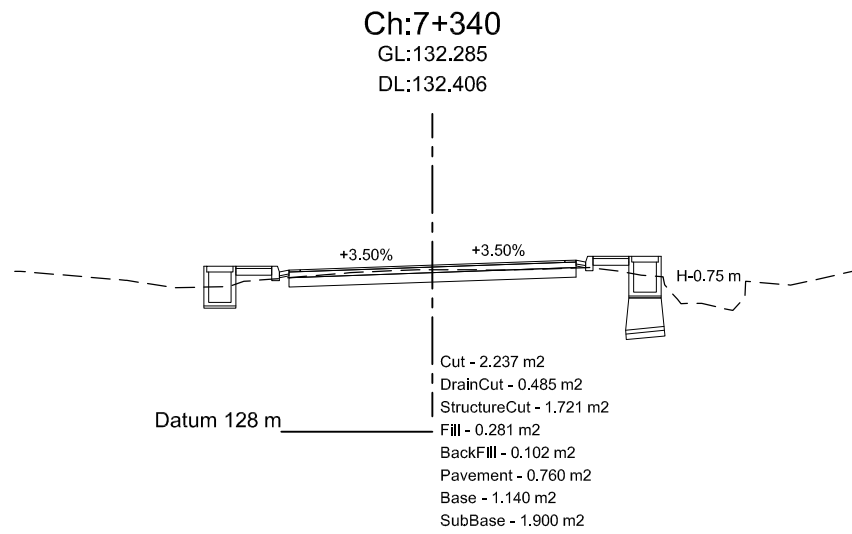

Department of Urban Development & Building
Construction (DUDBC)
Regional Urban Development Project (RUDP)
West Urban Corridor (WUC) Development Project
Babarmahal, Kathmandu, Nepal

Reviewed & Designed By :
DOHWA Engineering Co. Ltd.
in Association with
ERMIC (P.) Ltd., SILT Consultants (P.) Ltd., and
DIGICON (P.) Ltd.
Mid- Baneshwor, Kathmandu
Tel: 01-4589393

Consultant
Team Leader : YOO CHANGMIN
Reviewed By : YAGYA BAHADUR MALLA
Designed By : MANJU MUNANKARMI

Client
Approved By :
Checked By :

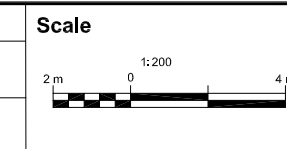

Cross-Section
BHALUHIPUL-MEDICAL COLLEGE-
BHATATOL-MUKHIYATOL-PIPARHIYA-
SINGHA-MUNICIPALITY
CH 0+000 - 7+503.82 Km

REV : MAY 2024
DRG NO : DM/RD/CS/45
CHAINAGE : 7+300-7+460
SHEET NO : 45

Ch:7+503.82

GL:132.721

DL:132.733

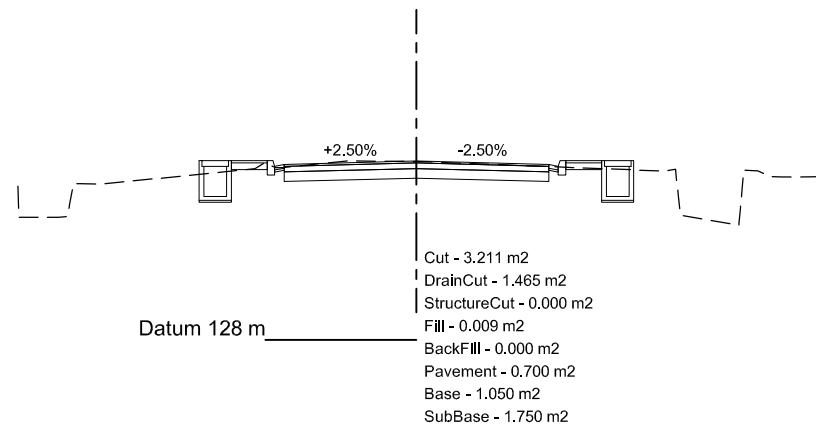

Ch:7+500

GL:132.645

DL:132.725

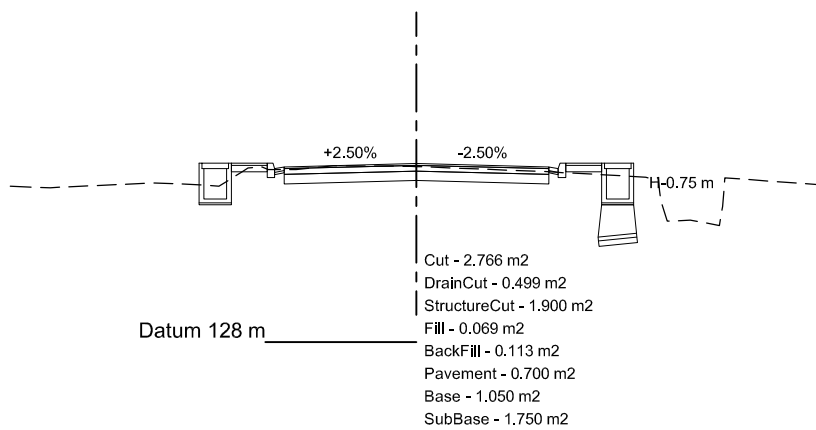

Ch:7+480

GL:132.474

DL:132.685

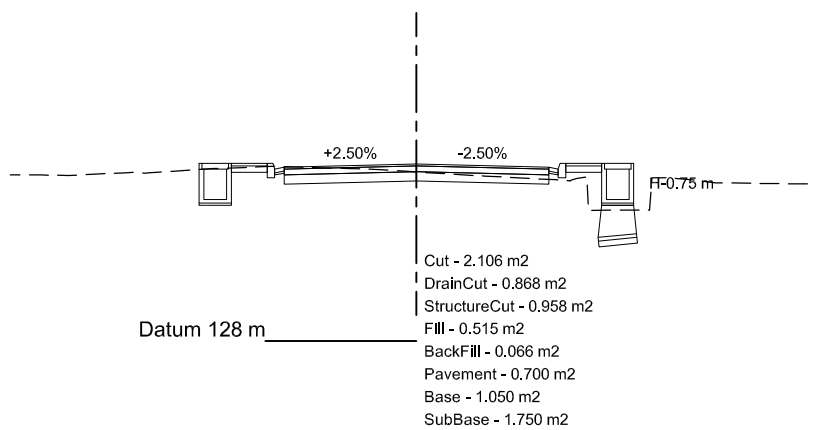

Department of Urban Development & Building
Construction (DUDBC)
Regional Urban Development Project (RUDP)
West Urban Corridor (WUC) Development Project
Babarmahal, Kathmandu, Nepal

Reviewed & Designed By :
DOHWA Engineering Co. Ltd.
in Association with
ERMIC (P.) Ltd., SILT Consultants (P.) Ltd., and
DIGICON (P.) Ltd.
Mid- Baneshwor, Kathmandu
Tel: 01- 4589393

Consultant
Team Leader : YOO CHANGMIN
Reviewed By : YAGYA BAHADUR MALLA
Designed By : MANJU MUNANKARMI

Client
Approved By :
Checked By :

Scale

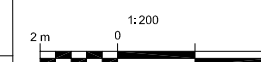

Cross-Section
BHALUHIPUL-MEDICAL COLLEGE-
BHATATOL-MUKHIYATOL-PIPARHIYA-
SINGHA-MUNICIPALITY
CH 0+000 - 7+503.82 Km

REV : MAY 2024
DRG NO : DM/RD/CS/46
CHAINAGE : 7+480-7+503.82
SHEET NO : 46